

FM 100-50

**NUCLEAR  
UNIT  
OPERATIONS  
IN  
COMBAT**



INTRODUCTION .....	1
PERSONNEL RELIABILITY PROGRAM .....	4
COMMAND AND CONTROL .....	6
FIELD OPERATIONS .....	13
TECHNICAL OPERATIONS .....	22
LOGISTICS .....	24
NUCLEAR ACCIDENT AND INCIDENT CONTROL .....	29
TRAINING AND READINESS .....	31
APPENDIX A, REFERENCES .....	34
APPENDIX B, STANDARDIZATION AGREEMENT (STANAG) NO. 2104 .....	36

## INTRODUCTION

### BACKGROUND

### SCOPE AND APPLICABILITY

### POLICY

### THE NUCLEAR ENVIRONMENT

This manual prescribes *doctrine* and *minimum standards* for units with a nuclear mission, operating under combat conditions in a combined conventional-nuclear environment. It provides *procedures* and *guidance* for those functions which are peculiar to nuclear missions and capabilities.

---

### Background

The precise time or the specific reason for the deployment of war reserve nuclear weapons from their peacetime environment cannot be predicted. They may be dispersed to Field Storage Locations (FSL) as a show of force under a strictly controlled peacetime condition; or they may be distributed to FSL during the height of combat.

Who actually will be responsible for the movement of weapons is also unpredictable. Weapon movement may be performed by combat, combat support, or combat service support units.

---

### Scope and Applicability

This manual pertains, as appropriate, to all echelons from engineer Atomic Demolition Munitions (ADM) teams, field artillery howitzer sections, and special ammunition supply and storage personnel through higher headquarters and larger units having a nuclear weapons mission.

The standards prescribed in this manual are considered the *minimum acceptable* for mission accomplishment. *Major commanders may modify them, but they may not reduce them.* Restraint should be exercised, however, to preclude imposing unreasonable or unrealistic requirements that could overburden units and degrade their capability for sustained combat operations.

For the purposes of this manual, a unit with a nuclear mission can perform, or be responsible for, at least one of the following functions:

- Security
- Maintenance
- Storage
- Transportation
- Assembly
- Firing/Delivery
- Demolition

---

## CHAPTER 1

---

*This manual is applicable to units which have a nuclear mission, under combat conditions, in a conventional-nuclear environment, and which have custody of war reserve nuclear weapons in an FSL or firing site. It is at this point that the unit assumes tactical wartime readiness posture in a deployed status.*

---

### Policy

---

The U.S. Army is a conventional-nuclear force. It must be *trained, organized, equipped, and psychologically conditioned* toward this objective — *anything less is unacceptable.*

The *nuclear mission* of U.S. forces is to *receive* nuclear weapons, *maintain* them in a safe and secure environment commensurate with their military and political importance and sensitivity and, when directed, to *deliver* them with design (predicted) performance against specified targets.

A tactical unit, selected for a special mission on a case-by-case basis to move, store, or secure war reserve nuclear weapons in peacetime, will be *trained, tested, and certified* especially for that mission. The mission statement will specify the type of weapons involved, the vehicles and/or aircraft to be used, the origin and destination of the move, the route to be followed, and the duration of the operation.

*Units must train as they will fight.* Training, testing, and readiness criteria will reflect only those functions which are essential to unit missions.

---

### The Nuclear Environment

---

The nuclear environment on the battlefield, whether active or threat, will impose tasks of an unprecedented magnitude on commanders and staffs at all levels. Nuclear units will share the problems of the maneuver forces which they support as well as those incident to their own nuclear capability.

Future conflicts will require units to mass overwhelming combat power to conduct an operation. Units in the *offense* will rapidly concentrate, making maximum use of camouflage, concealment, and the natural protection offered by the terrain. The *defense* must be active to fight successfully against superior numbers of attacking armored forces. It must make full use of

the combined arms team and the terrain.

Dispersal of combat formations, to minimize troop vulnerability to nuclear weapons, must be combined with the ability to concentrate rapidly. A compromise in the degree of dispersal must be achieved that allows for adequate troop protection while still retaining the ability to accomplish the combat mission.

*Success will depend on the first battle* and, just as there may be no opportunity for postmobilization training, so must our forces be prepared for nuclear combat. They must be trained to employ and exploit our weapons decisively and they must be trained, equipped, and conditioned to survive an enemy nuclear attack — to minimize disruption, to reestablish command and control, and to resume operations according to mission-type orders or unit Standing Operating Procedures (SOP).

Individuals must be mentally conditioned to the physical and emotional shock of the nuclear battlefield — against the sights, sounds, and smells, and against the realities of triage.

Nuclear units must establish and maintain close liaison with the units they support in anticipation of massive disruption of communications. Wire, unless well buried, is vulnerable to blast and thermal effects. Radios and other electronic devices are vulnerable to blackout, and the destruction of components from the effect of electro-magnetic pulse (EMP). Communications responsibility normally is from higher to lower echelons. Controlling headquarters and communications-electronics personnel and staffs must be aware of their responsibilities to provide priority assistance to nuclear units.

**NUCLEAR EFFECTS CREATE  
SEVERE MOVEMENT AND  
COMMUNICATIONS  
PROBLEMS**

## PERSONNEL RELIABILITY PROGRAM

### SCREENING AND EVALUATION

#### NUCLEAR DUTY POSITIONS

#### **PERSONNEL MUST BE RELIABLE AND HIGHLY QUALIFIED**

The nature of nuclear weapons is such that effective measures must be taken to ensure that they are not subject to any unauthorized or inadvertent acts which could degrade their performance over the target. The most important factors in providing a safe and secure environment for nuclear weapons are the reliability and qualification of the people who have custody of the weapons. The Personnel Reliability Program (PRP), as specified in AR 50-5, is designed to ensure that only reliable and qualified personnel are used in all phases of nuclear operations.

*Reliable personnel* are those whose mental, emotional, and physical health is such that they can be relied upon to perform their military duties in a consistent and predictable manner.

*Qualified personnel* are those whose training, aptitude, dexterity, and security clearances are commensurate with the tasks to be performed. Reliable, qualified personnel, properly supervised and adhering to approved standards and procedures are necessary to ensure a safe and secure environment for nuclear weapons.

### — Screening and Evaluation —

Prior to assignment to a nuclear duty position, personnel will be screened to determine suitability. Following assignment, personnel will be *continually* evaluated for retention in the PRP.

The initial screening consists of a check of personnel records by the personnel officer or his representative, a check of medical records by a medical doctor, an interview with a doctor if indicated during screening of the medical records, and an interview and determination of suitability by the unit commander. Medical personnel must be aware of the sensitivity of the PRP, and

must ensure that unit commanders are informed of conditions that could change the status of an individual in the PRP.

Once an individual is assigned to a nuclear duty position, the evaluation process continues until the individual is relieved of the duty: *The sensitive and critical nature of the duties involved requires that individuals in the PRP be continually evaluated by their commanders and peers as to their continuing proficiency, and freedom from circumstances or conditions that could degrade their reliability.* The reliability of individuals responsible for the safety, security, and eventual design performance of nuclear weapons over the target is not exclusively a peacetime requirement, but rather, is absolutely essential in combat.

### **EVALUATION IS A CONTINUING PROCESS**

Field operations and combat losses may preclude the accomplishment of all peacetime administrative procedures required for selection and screening of individuals selected to perform nuclear duties subsequent to the initiation of hostilities. Until such emergency conditions actually prevail, however, the provisions of Chapter 3, AR 50-5 will apply for all personnel filling nuclear duty positions. *Regardless of the conditions, commanders must ensure that only qualified personnel are used to perform nuclear duties.*

### **Nuclear Duty Positions**

The nuclear duty position, rather than the MOS, determines the requirement for an individual to be in the PRP. Each unit commander will identify the nuclear duty positions in his unit according to the criteria of Chapter 3, AR 50-5. After the positions have been identified, a properly authenticated Nuclear Duty Position Roster (NDPR) will be prepared listing the incumbent of each nuclear duty position by name, rank, security clearance, and SSN. The NDPR will be authenticated by the unit commander of his representative.

### **ASSIGNMENT DETERMINES INDIVIDUAL REQUIREMENT**



## COMMAND AND CONTROL

NUCLEAR CONTROL ORDERS

PERMISSIVE ACTION LINKS

NUCLEAR WEAPONS SAFETY RULES

SURVIVABILITY AND RESPONSIVENESS

OPERATIONS SECURITY

FIRE SUPPORT COORDINATION  
AND STRIKE WARNING

COMMUNICATIONS

TACTICAL SOP

The authority for, and the policies and procedures governing the use and safeguarding of SAS and PAL are promulgated by JCS to unified and specified commands in JCS PUB 13. Service headquarters are not authorized to supplement JCS PUB 13 except to amplify accounting instructions.

The uniqueness of nuclear weapons — their political sensitivity, their military potential, the risk of escalation inherent in their use, and the value of the active material as a national resource — requires that policies and decisions concerning them be made at the highest levels of government. This is the basis for command and control of nuclear weapons by the National Command Authority (NCA).

The NCA exercises command and control of all nuclear weapons through the Joint Chiefs of Staff (JCS). The JCS, in turn, prescribe special procedures for the authentication of certain orders affecting nuclear weapons, and for special devices and procedures which provide positive launch control through interruption of the assembly or firing sequence until secure enabling information is received. The former is accomplished by the use of Sealed Authentication Systems (SAS); the latter, by the use of Permissive Action Links (PAL).

### Nuclear Control Orders

The JCS have identified certain nuclear control orders (orders affecting nuclear weapons) that must be authenticated by the use of SAS. Nuclear control orders in less critical categories may be authenticated by nonsealed systems. Commanders of the unified and specified commands have established



Emergency Action Procedures (EAP) for the purpose of transmitting, receiving, and authenticating nuclear control orders. Commanders of U.S. Army forces assigned to unified commands have established their own EAP for their nuclear forces. Combat support and combat service support units, and appropriate intermediate command echelons, will be prepared to receive, transmit, authenticate, act on, and safeguard nuclear control orders as required.

Safeguarding of nuclear control orders requires the safeguarding not only of the information, but also of the related SAS material. This includes keeping it under two-man control and under suitable security in accordance with the provisions of JCS PUB 13.

### Permissive Action Links

Permissive Action Link (PAL) devices are mechanical or electro-mechanical devices which, when in use, positively disable the weapon system by interrupting the assembly or firing sequence. PAL devices are available for all U.S. Army nuclear weapons systems. Once a weapon system has been disabled by a PAL device, it can be enabled only by applying the proper combination to remove the mechanical device, or enable the electro-mechanical device, as appropriate.

The JCS have established policy and procedures for the control of PAL materials. Commanders of the unified and specified commands have amplified these procedures for PAL operations conducted within their respective commands. Department of the Army has established technical procedures for the enabling, disabling, maintenance, installation, and removal of applicable PAL devices.

Control should be exercised over ADM employment teams until the last possible moment. One method is to withhold PAL combinations until the team reaches the emplacement site (area). Authentication must be accomplished in accordance with prescribed procedures.

### Nuclear Weapons Safety Rules

Department of the Army publishes Secretary of Defense Safety Rules for each of its nuclear weapon systems. These rules are issued in the form of Army Regulations in the 50-1XX series. The purpose of these Safety Rules is to ensure that operations involving U.S. Army nuclear weapons systems are conducted in as safe a manner as possible consistent with operational requirements.

**SAFETY RULES ARE ISSUED  
BY THE SECRETARY OF  
DEFENSE**

Safety Rules provide positive measures to:

- Ensure adequate security
- Prevent *deliberate* prearming, arming, launching, firing, or releasing except upon execution of emergency war orders or when directed by competent authority
- Prevent *inadvertent* prearming, arming, launching, firing, or releasing
- Prevent weapons involved in accidents or incidents, or jettisoned weapons from producing a nuclear yield

U.S. Army nuclear weapon system Safety Rules apply to *all phases* of operations for a nuclear weapon system. They establish the basic framework, concepts, and rules within which approved operations may be conducted. They *do not* in themselves provide the authority to conduct operations.

Although the Safety Rules are mandatory for use in all nuclear weapons operations throughout the Stockpile-to-Target Sequence (STS), they *will not* abrogate or abridge the authority or responsibility of a commander to deviate from specific Safety Rules in an emergency. Commander discretion is essential in coping with an emergency. *Commanders must*, however, under any circumstance *ensure adherence to the two-man rule*. They must also ensure that U.S. forces maintain custody of U.S. nuclear weapons. The rules for each system may also specify restraints to remain in effect until certain additional conditions are fulfilled.

The JCS have directed that commanders of unified or specified commands which have nuclear capable units assigned, or have been charged with the support of allied nuclear capable units, assure implementation and compliance with the concept of operations and approved Safety Rules by all units, including allied forces, that participate in operations with nuclear weapons systems.

Army commanders will ensure adherence to these Safety Rules by all members of their commands. Commanders may prescribe additional rules that may be necessary to meet unique command requirements, or to comply with directives from the commander of the unified or specified command. However, the need for any additional requirements must be evaluated in terms of the impact on the operational capability of the nuclear units of the command.

#### THE TWO-MAN RULE

The two-man rule requires that a minimum of two authorized persons, each capable of detecting incorrect or unauthorized procedures with respect to the task being performed, and each familiar with applicable safety and security requirements, be present during any operation which affords access to a nuclear weapon. Two authorized persons will be considered to be present when they are in a physical position from which they can positively detect incorrect or unauthorized procedures with respect to the task being performed.

---

## Survivability and Responsiveness

Nuclear weapons will comprise a significant portion of U.S. combat power in any future war. *Their survivability and responsiveness are critical.* Units having custody of these weapons, or the capability of delivering them against an enemy, will be prime targets of enemy intelligence and target acquisition efforts. Their destruction or neutralization will be a high priority mission for enemy artillery, air, and airborne or airmobile forces. Survivability will depend heavily on all aspects of Operations Security (OPSEC).

*Survivability is not an end in itself.* To be meaningful, weapons and units must be responsive. Weapons must be safe and secure and in the hands of people who can deliver timely and effective fire against enemy targets. This requires that the weapons be immediately at hand, or located in close proximity to the delivery unit, that the principles of operations security be observed on the battlefield, and that delivery information and release data be expedited to the delivery or executing unit.

Effective, responsive procedures must be developed by the controlling headquarters, and practiced by command, staff, and delivery unit personnel. Skill in following such procedures by all personnel at both the staff and delivery unit levels cannot be overemphasized.

---

## Operations Security

The primary purpose of OPSEC is to avoid detection and, if detected, to mask capabilities or intentions.

This requires many coordinated actions by many agencies. Collectively these actions comprise OPSEC. Only through the awareness and diligent application of OPSEC principles, and integration of OPSEC requirements at all levels, can security and the full potential of surprise be realized, two elements essential to successful military operations.

Overall OPSEC planning and operations will originate at the highest levels, and nuclear units, like other units, may have specified roles in special types of OPSEC operations. All units must establish, and habitually observe, fundamental OPSEC requirements and procedures.

*Operations Security* includes physical security, signal security and information control as well as the use of tactical cover, camouflage, deception, decoys and dummy positions.

*Physical security* for nuclear units includes all the measures normally taken to ensure the security of any combat unit in a tactical situation, plus the special measures taken at Field

**SECURITY AND SURPRISE  
ARE VITAL INGREDIENTS TO  
VICTORY**

Storage Locations such as application of the two-man rule. Physical security of nuclear weapons will be completely integrated with overall unit defense plans, and will include evacuation, disablement, or emergency destruction as possible eventualities.

*Signal security* is achieved through the effective use of Communications Security (COMSEC), Electronic Security (ELSEC), and Compromising Emanations Control (CEC).

COMSEC consists of using telecommunications systems in such a manner as to deny information to the enemy in the event transmissions are intercepted. COMSEC can be maintained through such measures as:

- Use of proper procedures
- Use of authorized crypto systems
- Restrictions as to the use of certain types of communications equipment
- Control of undesirable emissions

ELSEC relates to measures applied to intentional electromagnetic radiations from such noncommunications equipment or systems as RADAR to prevent disclosure of operational information to the enemy.

CEC prescribes measures taken to prevent interception by the enemy of unintentional data-related or intelligence-bearing signals.

*Information control* is the control of written, spoken, visual, and graphic information in order to prevent disclosure of current or intended friendly operations. Information control includes:

- Screening and control of public information releases
- Classification, screening, or control of documents, publications, correspondence, and graphics
- Indoctrination or isolation of personnel to prevent spoken disclosures

Certain operations by nuclear units are susceptible to detection and analysis by audio, visual, photographic, and satellite observation. It is particularly important that nuclear units avoid operations or dispositions which have distinctive

Locations and destruction of friendly nuclear capability will be one of the enemy's highest priority missions. He will use every means at his disposal to determine which friendly artillery units actually have nuclear weapons, and to target these units and any supporting activities. Strictest adherence to established procedures and the use of protected transmissions are essential to the survival of nuclear forces.

### **SIGNATURES CAN COMPROMISE SECURITY**

signatures. Nuclear weapon convoys should not be distinguishable from any other type of convoy because of composition (number and types of vehicles), flags, placards, or types and signal patterns of communications equipment. Ordnance Special Ammunition Supply Points (SASP) and FSL should not be distinguishable by size, location, type of activity, or special security and firefighting measures.

Certain nuclear munitions have sound and flash characteristics which may identify them as nuclear artillery. To minimize the effects of enemy counteraction, commanders should consider using lone gun or offset positions and remote missile firing points, or moving weapons to alternate positions immediately following a nuclear mission.

While deception may be planned and implemented on a grand scale at the highest echelons, the small unit commander must rely on camouflage, camouflage discipline, light and sound discipline, alternate and dummy positions and routes, and decoys as the best means of ensuring the survival of his unit and the ultimate accomplishment of his nuclear mission.

**COMMAND INGENUITY AND  
INDIVIDUAL SOLDIER  
AWARENESS IS THE KEY TO  
SURVIVAL ON THE NUCLEAR  
BATTLEFIELD**

---

### **Fire Support Coordination and Strike Warning**

Fire support is the close and continuous assistance to those elements of the force in contact with the enemy. Fire support coordination is the planning and execution of fire in support of those elements which close with the enemy.

The advent of nuclear weapons has not changed the established principles of fire support coordination. However, the increased lethality and variety of effects place increased importance on methods and procedures for safeguarding friendly troops and activities. Standardization Agreement (STANAG) No. 2104 (Appendix B of this Field Manual), to which the U.S. has subscribed, establishes a standard warning message and defines the notification channels which will ensure timely warning of friendly nuclear strikes.

---

### **Communications**

The variety of circumstances and the exacting demands of effective command and control of nuclear operations underline

the need for adequate, secure, and reliable communications. Equipment maintenance and operator training must be maintained at peak efficiency, an especially difficult task since communications capability in lower echelon units is usually austere at best.

The threat of EMP destruction of electronic components dictates that a portion of a unit's radios habitually be disconnected and protected by a shelter or other attenuation means. This will aggravate the already austere communications situation, and will require the most efficient procedures and control of radio traffic.

### **EFFECTIVE TRAINING SIMULATES FIGHTING**

*Units must train as they will fight.* During training exercises, units should operate part of the time without a portion of their authorized communications capability in order to develop procedures for continuing operations in the face of possibly drastically reduced communications capability.

---

### **Tactical SOP**

---

Units at all levels normally develop SOP, the content of which will vary depending on SOP of higher commands with which lower echelons usually are required to comply, the state of training of units, and variations in operating conditions that units encounter.

#### **Effective SOP will:**

- Reduce the number, length, and frequency of other types of orders
- Simplify the preparation and transmission of other orders
- Facilitate and expedite operations
- Reduce confusion and errors
- Simplify training

The advantages of training and fighting with an adequate SOP in a conventional conflict are numerous. In a nuclear conflict, the difference may be *critical* to the successful accomplishment of the mission. With the obvious requirement for close coordination between maneuver forces and combat support, and between combat support and combat service support, developing and training with a good SOP and fighting with mission-type orders can reduce the impact of the nuclear environment and contribute to success in combat.

**FIELD OPERATIONS**

PHYSICAL SECURITY

THE TWO-MAN RULE

CUSTODY AND ACCOUNTABILITY

MOVEMENT IN COMBAT

FIELD STORAGE

REMOTE FIRING POINTS  
AND HIDE POSITIONS

Several aspects of field operations are of particular concern to commanders of nuclear units. These are:

- Physical security
- Custody and accountability
- Movement of nuclear units in combat
- Field storage of nuclear weapons
- Firing points and hide positions

**Physical Security**

The primary sources of security during combat for a unit's materiel, including its weapons, are the *tactics* and *security measures* employed by the unit. Since extended frontages and widespread troop dispersion will severely tax the ability of maneuver units to assist other units under local attack, *nuclear units must be prepared to provide for their own security on the battlefield*. Maneuver commanders must be sensitive to such situations, and must be prepared to provide all possible assistance to preclude weapon loss.

Each unit will form a reaction force as an integral part of its unit defense plan. The primary tasks of the reaction force will be to:

- Strengthen a threatened portion of the defense
- Destroy or eject any enemy who penetrates the perimeter
- Restore the integrity of the unit position.

**AN ADEQUATE DEFENSE PLAN  
REQUIRES A REACTION  
FORCE**



The reaction force for an artillery battery will approximate an infantry rifle squad in size and composition. For supply points and larger activities, both the local security force and the reaction force will be considerably larger. The reaction force commander, who will be designated by the unit commander, will supervise the reaction force, and will ensure that the force receives *complete instructions*, including the *signal for*, and the *place of, assembly*. Nuclear units will coordinate with adjacent units for additional support when the security of the nuclear units' weapons is threatened, and it is beyond the nuclear units' capability to provide adequate security.

Defense of the FSL within a field artillery battery position is an untenable concept. If destruction or overrun of the battery is imminent, emergency evacuation, disablement, or emergency destruction (ED) procedures should be implemented.

Initial efforts to establish effective security in a tactical position will be directed toward overall security of the unit position. First in order of priority will be the establishment of a defensive perimeter, followed by improvements to nuclear field storage locations, and command and control facilities as time and resources permit.

Weapons will be transferred between units by designated couriers and maintained under two-man control *at all times*. Unit security SOP will be based on security standards and procedures from higher headquarters, and will prescribe the procedures to be followed by the unit in providing security for nuclear weapons in its custody during movement, storage, and prefire operations.

Depending on the tactical situation, Special Ammunition Supply Points (SASP) (and their parent direct support (DS) and general support (GS) units) stocking nuclear weapons may need augmentation of their organic security capability. *Force commanders must plan for this contingency.*

---

### The Two-Man Rule

---

The two-man rule is designed to prohibit access to a nuclear weapon by a lone individual, and thus preclude either inadvertent or intentional damage to, or unauthorized firing or launching of a weapon. When application of the two-man rule is required, it will be enforced *constantly* by the two persons who constitute the team, while they are accomplishing the task or operation assigned, and *until they leave the area within which it is to be performed*. The two-man rule will be applied as

required by Nuclear Weapons Safety Rules, applicable surety and security regulations, operations directives, and SOP.

---

### Custody and Accountability

---

Nuclear unit commanders will be prepared to assume custody of nuclear weapons. This consists not only of *physical possession* of the weapon, but of *total responsibility* for its movement, storage, security, safety, and maintenance, as well as related accident and incident control, and compliance with procedures for the authentication and safeguarding of nuclear control orders. DD Form 1911, Material Courier Receipt, will be used for the transfer of custody of nuclear weapons or components during movement. DD Form 1150 will be used for transfer of custody during storage.

Accountability of nuclear weapons will be by continuous receipts. During combat, issue of conventional ammunition in most cases has been tantamount to expenditure. However, the accountability of nuclear weapons does not end until the weapon is expended or destroyed, and then only through proper reporting procedures. Accountability procedures will be in accordance with the provisions of AR 700-65, Nuclear Weapons and Weapons Material, and TM 39-100-1, Supply Management of Nuclear Weapons Material. DD Form 1348-1 will be used for transfer of accountability.

#### **ACCOUNTABILITY IS A CONTINUING PROCESS**

---

### Movement in Combat

---

Nuclear units will be required to move nuclear weapons on the battlefield. Weapons may be moved in organic vehicles or aircraft by artillery and engineer units, or by ordnance units in organic or supporting transportation unit vehicles and aircraft. Weapon-carrying vehicles will be inspected prior to the move to ensure that, *as a minimum*, the vehicle is free of electrical or mechanical defects which could prevent safe arrival.

Route planning will include provisions for enroute security commensurate with any anticipated threat. Maneuver commanders should be prepared to assist in providing security during movement, as required.

#### **PROVISION MUST BE MADE FOR SECURITY DURING MOVEMENT**

During displacement or movement to remote firing positions,

The courier will be responsible for establishing a custodial chain of command. He will have in his possession the following forms:

- DD Form 1150, Request for Issue and Turn-in
- DD Form 1348-1, DOD Single Line Item Release/Receipt Document
- DD Form 1911, Material Courier Receipt
- DA Form 581, Request for Issue and Turn-in of Ammunition

nuclear weapons carriers will be so located in the convoy as to provide *maximum* protection to the weapons. During surface resupply, e.g., an artillery or engineer unit picking up weapons from a SASP, *minimum* security measures will consist of a designated courier (officer or NCO), a driver and assistant driver for each nuclear weapons carrier, and a security force commensurate with the expected threat enroute, *but consisting of no less than five armed individuals*. Larger surface resupply movements, such as between SASP or within the COMMZ, will require a security force commensurate with the number of weapons being moved and any anticipated threat. During any move, the courier will maintain radio contact with a headquarters capable of responding to a request for assistance from the courier.

The courier, and the drivers and assistant drivers of nuclear weapons carriers, *must be in the PRP and on the unit's NDPR*. This requirement also applies to drivers and assistant drivers of vehicles immediately following nuclear weapons carriers. During the move, the driver and assistant driver of each vehicle carrying nuclear weapons, and the driver and assistant driver of the vehicle following each vehicle carrying nuclear weapons, will constitute the required two-man control for the weapon(s) being carried. All drivers and assistant drivers will be specifically informed of their responsibilities prior to each move.

The commander responsible for the movement will provide or arrange for adequate additional security for the convoy if the tactical situation is such that he does not have the resources available to assure the safety and security of the convoy. He will also maintain a capability to execute the emergency destruction of his weapons if the loss of the weapons appears imminent.

Nuclear weapons may be moved by Army aircraft within the combat zone, or forward from the COMMZ into the combat zone. Only aircraft and/or weapon combinations and modes for which *approved procedures* have been published will be used. A courier and a guard will constitute two-man control for the weapons aboard the aircraft.

The shipping and receiving units, respectively, are responsible for loading and unloading the weapons. The aircraft commander and crew are responsible for proper tie-down procedures. Personnel involved in air movement should take all possible actions to reduce the vulnerability of the operation to detection and destruction by the enemy. Loading and unloading should be

The commander responsible for air movement must maintain contact with the mission, and should place a backup aircraft on ground alert if one is available.

"tailgate-to-tailgate" operations, and should be executed as quickly as possible with full observance of applicable OPSEC measures.

Applicable tie-down procedures will be used for the weapon-vehicle and/or aircraft combination involved. When vehicles without standard tie-down equipment are used, the tie-down procedures outlined in Appendix B of the appropriate Technical Manual will be used.

Restrictions on weapon numbers and arrays will be observed during transport and storage. To permit maximum use of available transportation within nuclear units in combat, nonnuclear munitions such as the items constituting a complete nuclear round (spotting rounds, powder charges, and missile components), as well as HE ammunition, can be transported in the same vehicles as nuclear munitions. Nuclear weapon tie-down procedures and explosive compatibility standards during such moves will be observed.

If two-man control and other security provisions for the prescribed nuclear load can be provided, the PNL can be dispersed throughout the column to minimize potential loss from enemy action. By the same token, demolition materials can be transported with nuclear weapons in accordance with provisions of Appendix B of the applicable -12 or -20 TM. Unit SOP should standardize movement of ammunition within general guidelines.

It is essential that stereotype patterns of activity do not evolve at locations where movement of nuclear weapons originate and terminate. Such signatures could identify the activities as nuclear-related, and alert an enemy of an impending movement of nuclear weapons. The principles of OPSEC must be followed at all times.

### Field Storage

Each nuclear unit having custody of nuclear weapons in combat will establish a field storage location (FSL) in which to store its weapons. The primary purpose of the FSL is to preclude unauthorized and uncontrolled access to the weapons. The FSL will be within the unit perimeter and normally will be demarcated by placing a single concertina around the storage area; a single entrance will be designated. If concertina is not available, barbed wire, rope, or other such material may be used.

Communications will be established between the battery FSL and battery operations center, and between the battery operations center and remote firing positions. Security for ADM assembly and emplacement sites should be provided by the executing commander in accordance with provisions of FM 5-26 and FM 5-26A.

Entry into the FSL will be controlled by two guards at the single entrance. *Both must be in the PRP and on the NDPR.* A *minimum* of one additional guard will be posted outside the FSL, on the side *opposite* the entrance. Additional guards will be posted around the outside of the FSL as determined necessary by the unit commander to ensure intervisibility between guards and complete surveillance of the total perimeter of the FSL.

TYPICAL FIELD STORAGE LOCATIONS (FSL)

LEGEND:

- ⊗ Personnel in PRP
- ✕ Unit Personnel
- ✖ Additional Security Posts if Determined Necessary by Commander

Equipment, personnel, and positioning according to unit SOP

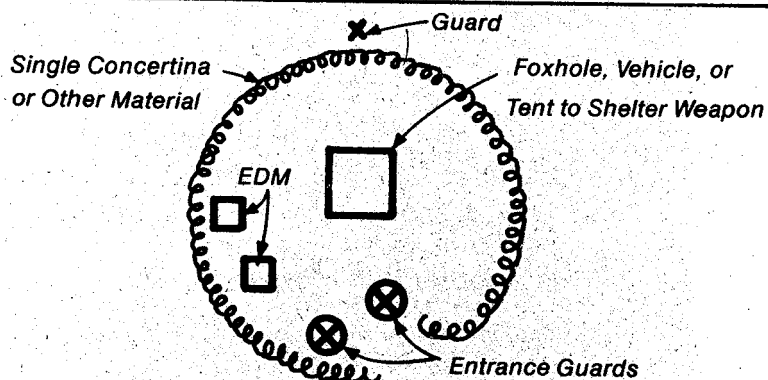

Field Artillery Howitzer Battery

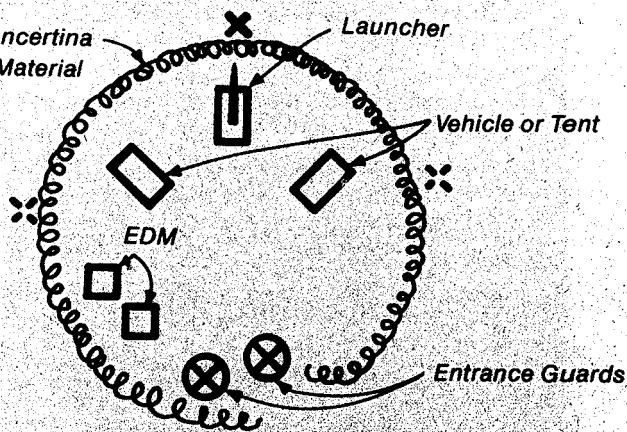

Field Artillery Missile/Rocket Battery

The number of additional guards required will vary as a function of weather, terrain, or such artificial obstacles inside the FSL as tents or vehicles. These additional guards can be ordinary interior guards and need not be in the PRP or on the NDPR. Since the security of the FSL is basically dependent upon the

tactical security of the unit, the purpose of these additional guards is to preclude unauthorized access to the FSL by preventing inadvertent entry by unit personnel, and by directing personnel seeking entry into the FSL to the established entrance. Unit SOP will prescribe the duties of security personnel during an emergency.

FSL entrance guards will have an entry control roster (ECR) listing, by name, rank, and SSN, personnel who regularly require entry into the FSL. The entry control roster *must indicate an expiration date, and must be signed by the unit commander or his authorized representative.* The NDPR may be annotated to indicate unit personnel authorized access to the FSL, in which event it can serve as both the NDPR and ECR. *If the NDPR is used as the ECR, it must also show an expiration date.*

Entry into the FSL by personnel listed on the ECR will be based on visual recognition by the entrance guards. The unit commander, or his authorized representative, may verbally authorize entry into the FSL by personnel who are not on the ECR. Written guard orders are not required; however, standard security measures practiced in the unit should be clearly defined in the unit SOP.

In establishing a unit FSL, every effort will be made to provide a safe and secure environment for the weapons while concealing the nature and purpose of the activity. A truck or a tent may offer shelter and convenience, but it will not provide protection against small arms or automatic weapons fire, or shell fragments. An armored personnel carrier or a foxhole will offer better protection for the weapons. A foxhole at the FSL entrance will also afford protection for the entrance guards, and will make them less noticeable to a distant observer.

The enemy will often have a strong suspicion that he is facing a nuclear unit, and he will be looking for confirmation. Any stylized operational characteristics may strengthen or confirm the suspicion. Therefore, any signature-type layout or operation of the FSL must be avoided.

### **ENTRY INTO THE FSL MUST BE STRICTLY CONTROLLED**

*If, in an emergency situation, an ECR is not available, entry into the FSL may be permitted following personal recognition by the entrance guards, the unit commander, or his designated representative. Regardless of the circumstances, the two-man rule will be observed.*

### **Remote Firing Points And Hide Positions**

Commanders must assume that the destruction or neutralization of friendly nuclear capability will be a high priority mission for enemy artillery. To minimize the effects of enemy counteractions, commanders of nuclear delivery units should

consider using remote firing points or offset positions, since enemy counterfire against these remote or offset positions normally will not endanger the parent firing unit.

Commanders may also consider using hide positions near the firing positions. Projectile assembly teams or FA MSL/RKT firing platoons can remain in these hide positions, moving into the firing position just prior to a fire mission.

TYPICAL REMOTE FIRING POSITIONS

LEGEND:

⊗ Personnel in PRP

× Unit Personnel

\* Required Only After Assembled Round is at Howitzer

PRP Personnel Move to Firing Pit Just Prior to Launch

Equipment, personnel, and positioning according to unit SOP

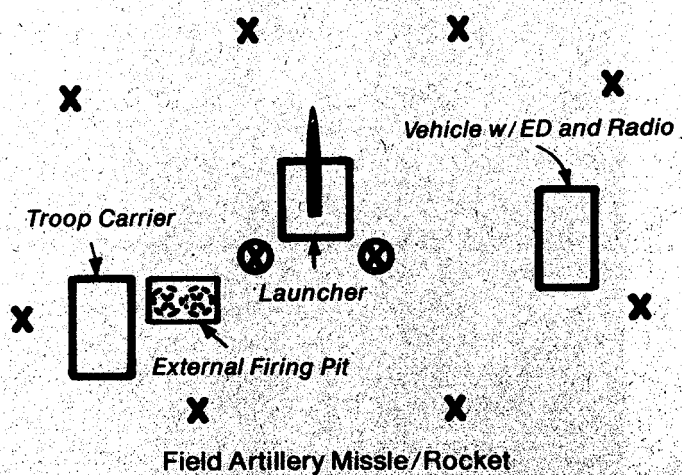
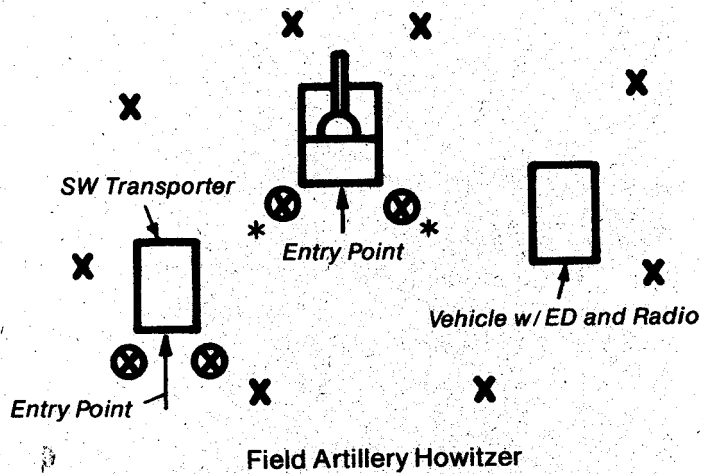

Commanders will ensure that normal physical security standards for nuclear weapons are followed for nuclear weapons at



remote firing positions and in hide positions. Since these positions normally will be occupied for only short periods of time, use of physical barriers will be minimal; an ECR will not be required. Assembly teams for cannon units, and firing platoons for FA MSL/RKT batteries, have enough personnel in the PRP to control access to nuclear weapons at remote and hide positions. Any other individuals who are not members of the teams or platoons, and who require access to the positions, will be vouched for by the team or platoon commander according to unit SOP.

TYPICAL HIDE POSITIONS

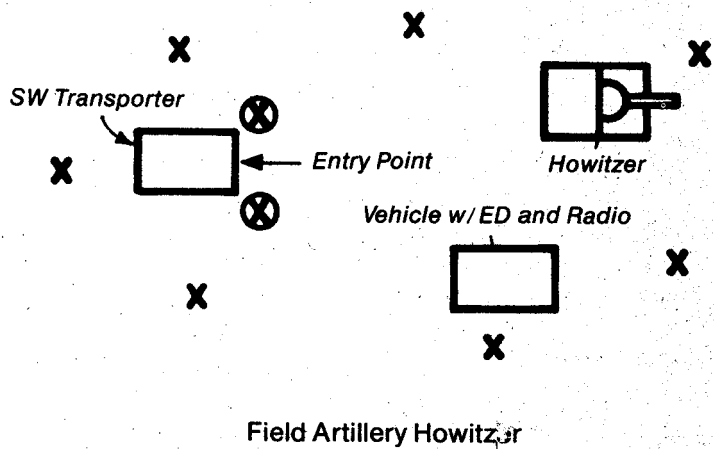

LEGEND:

⊗ Personnel in PRP

X Unit Personnel

Equipment, personnel, and positioning according to unit SOP

Field Artillery Howitzer

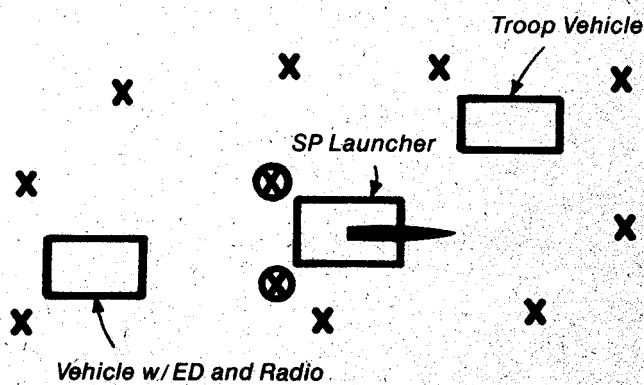

Field Artillery Missile/Rocket

## TECHNICAL OPERATIONS

### EMERGENCY DESTRUCTION

Technical operations in nuclear units are primarily of a technical nature and nuclear-weapon peculiar, as opposed to operations normally performed on nonnuclear materiel by combat support and combat service support units.

Technical operations consist of such weapon-related activities as unpackaging and repackaging, assembly, prefire, cancel fire, disarm, periodic maintenance, storage monitoring, and emergency destruction. Technical operations will be performed according to provisions of the appropriate Safety Rules and weapon technical manuals. For HONEST JOHN, 8-inch and 155mm howitzers, SADM, and MADM, all prefire operations are covered in an appropriate operator manual (a TM in the -10 series). Technical operations related to the LANCE, SERGEANT, and PERSHING nuclear weapons are described in technical manuals in the -12 series. Emergency destruction of all nuclear weapons will be performed according to provisions of the applicable system TM -20 series and TM 39-50-8, Emergency Destruction of Nuclear Weapons.

### Emergency Destruction

Command disablement or emergency destruction (ED) of nuclear weapons may be required to prevent the capture or use of U.S. weapons by the enemy, or the compromise of design information. Disablement or destruction is mandatory when:

- A combat unit or position is about to be overrun
- A combat unit is unable to evacuate a part or all of its weapons during a withdrawal
- A rear area storage site is threatened by a major penetration, a vertical envelopment, or a major attack by guerrilla or underground forces

#### **UNIT SOP WILL SPECIFY EMERGENCY DESTRUCTION PROCEDURES**

Unit SOP will provide for ED of the unit's nuclear weapons. The unit's normal ED capability (i.e., ED materials, personnel designated, time allotted for execution) will be of sufficient level to ensure emergency destruction of all unit weapons. The SOP will specify:

- The amount of ED material to be on hand at all times
- How and where ED material will be carried during movement
- How and where ED material will be stored with reference to the unit FSL, SASP, or major storage area
- Who in the unit is authorized to order ED and how the order will be disseminated
- Which unit personnel will execute the ED
- How execution of ED will be coordinated with other emergency operations (e.g., local defense, withdrawal, evacuation, and destruction of other classified or major items of equipment)

By its nature, emergency destruction will take place during a period of great stress and confusion. *Commanders must ensure that sufficient personnel, trained and designated to execute ED, will be available and will not be so committed to perimeter defense or to some other activity that they cannot disengage to execute ED on order.* Selected personnel will also be trained in secondary methods of destruction.

Emergency destruction may be directed by higher headquarters, or it may be executed at the discretion of the immediate commander or the senior survivor, based on the situation. Except in the most unusual circumstances, emergency destruction of larger stocks to the rear will be executed *only on order from the major commander concerned* (e.g., corps, COSCOM, TAACOM, or independent task force). Any ED order originating outside of the unit having custody of the weapons or material to be destroyed *will be authenticated* in accordance with authentication procedures prescribed in Chapter 3 of this manual, and in command SOP and Communication Electronics Operating Instructions (CEOI).

Command disablement should be considered when time does not permit a unit to destroy weapons in accordance with established ED procedures. Unit SOP will provide for command disablement in accordance with theater guidelines.

**AUTHENTICATION OF EMERGENCY  
DESTRUCTION ORDERS MAY  
BE REQUIRED**

## LOGISTICS

SUPPLY

SERVICE

COMMZ

COMBAT ZONE

DISTRIBUTION

DISTRIBUTION OF SPECIAL  
AMMUNITION

MAINTENANCE

The procedures for the supply, service, distribution, and maintenance of special ammunition closely parallel those of conventional ammunition. There are, however, some significant differences. These relate primarily to the *organization and operation* of Special Ammunition Logistical Elements (SALES) and Special Ammunition Supply Points (SASP).

---

## Supply

---

Ammunition supply in the theater of operations is provided at the DS and GS levels. At the GS level, special ammunition GS-DS companies operate GS activities and at the DS level, DS special ammunition companies operate Special Ammunition Supply Points (SASP).

Staff supervision of ammunition supply in major combat service support headquarters is exercised by ammunition service staff personnel included within the staff of the ACofS, Materiel, at the headquarters of:

- Theater Army (TA) Headquarters
- Theater Army Area Command (TAACOM)
- CORPS Support Command (COSCOM)

Ammunition service personnel in the Materiel Management Center (MMC) perform ammunition supply management at

these various headquarters. The MMC can also provide personnel to form Special Ammunition Logistical Elements (SALES) to aid in supply and resupply of special ammunition. These elements are typically located at the headquarters (e.g., tactical operations center) of the senior commander concerned.

---

### Service

*Ammunition service* consists of the *supply and maintenance support* of conventional and special ammunition, including maintenance of guided missile systems. Supply and maintenance support includes:

- DS and GS supply of all types of conventional and special ammunition
- DS and GS maintenance of special ammunition materiel including test and handling equipment, and nuclear weapon trainers
- GS supply of repair parts peculiar to special ammunition
- GS maintenance of all missiles, rockets, and missile system peculiar ground guidance and launching equipment, special tools, and peculiar test and handling equipment used in support of mission items
- DS maintenance and supply support of all special ammunition repair parts and missile repair parts
- Explosive ordnance disposal (EOD) service

---

### COMMZ

Ammunition GS supply activities are part of the general support structure of the TAACOM. These activities may contain both conventional and special ammunition units. They provide DS support to using units located in their areas of responsibility within the COMMZ. Some GS activities maintain combat-essential theater reserve stocks. They also serve as a means of dispersing stocks within the COMMZ and provide an *emergency source* for the combat zone when shipments cannot be made from other sources. *They have no routine responsibility to resupply the COSCOM*, which receives throughput shipments directly from CONUS and maintains its own reserve stocks.

**Combat Zone**

Special ammunition supply points in the *combat zone* are operated by ordnance special ammunition direct support companies located close behind division rear boundaries where direct support demands are heaviest. General support activities are operated by ordnance special ammunition companies, GS/DS. These units:

- Maintain combat zone reserve stocks which are dispersed throughout the corps rear areas
- Replenish SASP stocks
- Operate small DS supply points for local units

**Distribution**

Ammunition is normally distributed to using units through supply points. Maximum throughput distribution is a basic characteristic of ammunition supply. The preponderance of throughput distribution is from CONUS to DS supply points and GS activities in the combat zone. Air transport is the most common means of delivering special ammunition to the theater

**SPECIAL AMMUNITION DISTRIBUTION**

**LEGEND:**

→ Normal Flow

- - -> Alternate Flow

□ Special Ammunition Supply Activity (SASA)

○ Special Ammunition Supply Point (SASP)

**NOTE:** A maximum amount of special ammunition will be shipped to the Corps by air.

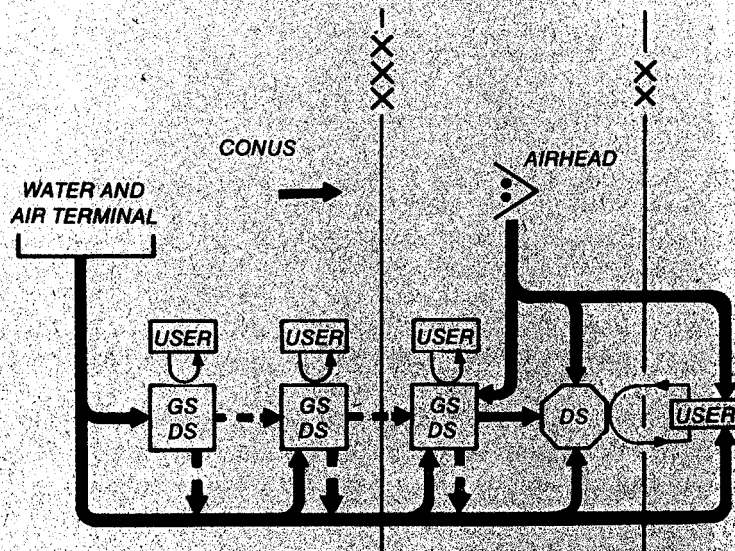

of operations, especially for throughput distribution. Since distribution of special ammunition depends on command decisions, the desires of the tactical commander to whom these items are allocated govern the locations to which they are delivered. The corps commander normally allocates ammunition to each division based on the main and supporting tactical efforts. In any situation, *throughput distribution of ammunition requires close coordination* between the corps headquarters and the COSCOM MMC to ensure that ammunition is routed or rerouted to *meet tactical changes*. In addition, *close coordination between the COSCOM and ammunition group headquarters is needed to relocate ammunition supply units within the combat zone to meet varying requirements*.

### Distribution of Special Ammunition

Special ammunition is allocated through tactical command channels to corps and division commanders. The commanding officer of the supporting logistic headquarters (COSCOM or TAACOM) provides the means to ensure that ammunition requested reaches the tactical commander. Special Ammunition Logistical Elements (SALES), formed from resources available to logistic commanders, control special ammunition at corps and theater (e.g., air defense headquarters) tactical operations centers. Generally, the mission of a SALE is to expedite the flow of directives concerning the supply of special ammunition from the tactical operations centers through the MMC to the storage locations. Stockage levels for special ammunition are established by command decisions as a function of the special ammunition distribution to maneuver (supported) elements, and the Prescribed Nuclear Load (PNL) of supporting units. Supported nuclear firing or demolition units *must be informed* of the location of supply points that stock items necessary to constitute a complete nuclear round.

Planners must ensure that special ammunition stockage levels are supported by adequate stockage levels for nonnuclear items to ensure availability of complete nuclear rounds (i.e., a nuclear projectile or warhead section, powder charges, spotting rounds, and missile components).

### Maintenance

The levels of special ammunition maintenance include organizational, DS, and GS. *Organizational maintenance*, performed by the using units, *ensures materiel readiness*. Generally, little maintenance of special ammunition is done at the DS level. The SASP receive and evacuate the unserviceable rounds or



components to the GS level for repair. At the GS level, the special ammunition company (GS/DS) performs the actual repair of unserviceable special ammunition for return to stock and provides GS supply of repair parts peculiar to special ammunition. The DS special ammunition company provides DS supply of these repair parts. The repair parts companies of the support group supply and service battalion provide repair parts for special ammunition that are common to more than one system. Rockets and guided missiles (less explosive components and adaptation kits) are maintained by the Ordnance General Support Maintenance Company, and by Ordnance Rocket and Missile Support Teams.

## NUCLEAR ACCIDENT AND INCIDENT CONTROL

COMBAT ENVIRONMENT

HAZARDS

EMERGENCY MEASURES

Nuclear accident and incident control (NAIC) is an operation whose objectives are, in the event of an accident or serious incident involving nuclear weapons, to:

- Minimize injury and loss of life, hazardous effects, and destruction of property
- Secure classified information and materiel
- Maintain public confidence in the ability of the Army to handle nuclear materiel and respond to an accident if necessary

During wartime, the objectives will be generally the same, but the priorities may be considerably different, and the *impact on military operations or on relations with friendly foreign nationals* in overseas areas may become *overriding considerations*.

---

### Combat Environment

The combat environment will *significantly* increase the chances of nuclear weapons being involved in accidents or incidents. Direct enemy action, the increased probability of vehicle and aircraft accidents, handling accidents, and fires all offer potentially hazardous situations for nuclear weapons. Commanders and staffs *must provide the safest possible environment for their weapons*, and must be prepared to implement necessary measures in the event an accident occurs. Inherent safety features designed into nuclear weapons should preclude any significant nuclear yield from a weapon involved in an accident. However, a weapon involved in a fire, HE explosion, or mechanical rupture may spread and deposit radioactive products of plutonium and uranium. *Any partial nuclear yield will produce a radiation hazard.*

---

Hazards

---

The primary hazard associated with plutonium results from alpha-emitting particles entering the body by inhalation or ingestion, or through deep puncture wounds. Protection is provided by masks against inhalation, by caution against ingestion, and by thorough washing and bandaging of deep wounds. Absorption through unbroken skin or shallow wounds is of negligible concern.

Uranium particles may enter the body in the same manner as plutonium particles, but they constitute less severe radiological health hazards. The principal hazard from uranium is heavy metal poisoning. Chunks of uranium emit gamma radiation. Emergency crews can be protected by controlling stay-time in areas where gamma radiation is being emitted.

With an understanding of the hazards associated with a nuclear accident, common sense can preclude or reduce casualties.

---

Emergency Measures

---

Nuclear Accident and Incident Control (NAIC) measures can be divided into three phases: emergency actions; gaining control of the accident site and determining the hazard level; and site recovery. NAIC procedures in a combat situation should be based on pertinent portions of FM 3-15, Nuclear Accident Contamination Control. They should be incorporated in unit SOP, and coordinated with the Area Damage Control plans of adjacent and higher units.

Emergency actions following a nuclear accident or incident include: *rescue, first aid, and evacuation* of injured personnel (properly tagged for identification to medical personnel as being contaminated); *firefighting; warning* personnel downwind of the possible presence of radiation; *restricting* movement into the accident site; and *rendering* the weapon safe.

Actions that should be taken to control the accident site include: *establishing* a control point; *determining* the extent of the contaminated area; *marking off* the contaminated area; and *disposing* of remaining weapon material.

Site recovery actions should include: *decontamination*, if feasible; and *evacuation* of the area.

**UNIT SOP SHOULD CLEARLY  
DEFINE EMERGENCY  
MEASURES**

## TRAINING AND READINESS

### TRAINING POLICY

### TRAINING OBJECTIVES

*The ultimate goal of all military training is a level of combat readiness to ensure success in battle. To achieve this goal, training must have identifiable and attainable objectives, and must be carefully planned and executed with emphasis on realism, accuracy, and professionalism.*

The power and lethality of a single nuclear weapon is unprecedented. The combat potential of a single nuclear unit likewise is unprecedented, and the total potential of a well trained tactical nuclear force extends beyond the battlefield into the sphere of international diplomacy and deterrence. *Nuclear training must be as thorough, comprehensive, and imaginative as the uniqueness of nuclear weapons requires.*

### Training Policy

In order to operate as part of the conventional-nuclear force, each nuclear unit must be *thoroughly trained* for its total mission. Teams and specialists will be trained as appropriate. The nuclear capability must be integrated into the total mission capability without degrading or detracting from either the nuclear or conventional capability.

Complete integration begins with training, and *must be habitual*. For instance, when a unit conducts field training or participates in a training exercise, tactical moves should include a nuclear load (training or dummy weapons) complying with tie-down, spacing, and security requirements, and the unit position should include an FSL. Exercise scenarios should provide nuclear play exercising the nuclear capability. Integrated capability should be maintained; i.e., simulated nuclear missions will not be fired early in the exercise so that the FSL and other nuclear responsibilities can be closed out.

For field artillery units, scenarios should include day and night simulated nuclear missions, and live conventional fire missions. For ADM teams, exercises should be conducted under field conditions, and should include active communications and their ability to use target folders.

**During training, and particularly during proficiency and readiness testing, resources must be allocated against total mission accomplishment in a sustained combat situation.**

In the interests of realism, major commanders having the capability to provide realistic support should do so rather than rely on simulation. For example, if an ordnance DS company is available, it should support an artillery or engineer unit with an operating SASP, and the ordnance unit should be evaluated concurrently on its support of the nuclear delivery or emplacement unit or team.

---

### Training Objectives

---

*The overall objective of nuclear unit training is to develop units that will fulfill their missions in combat with the greatest possible effectiveness and least possible loss of human and material resources.* Standard training objectives for most units will be to ensure proficiency in unit operations. For example, artillery units will be proficient in firing procedures, data computation, survey, communications, and local security; ammunition supply companies will be proficient in moving, storing, and performing maintenance on ammunition.

Nuclear units must be able to thoroughly integrate the nuclear aspects of their mission into total unit capability. An *effective unit* will reflect *well trained, confident, highly motivated* individuals molded into smoothly functioning teams. While these ingredients are common and necessary to any well trained unit, they are *critical* to the nuclear mission.

The first tactical nuclear weapon has yet to be fired in combat. Results of shots in the nuclear test program show the devastation of structures, equipment, and dummies in the test area. The average soldier, without any follow-up instruction or qualification of these effects films, logically expects the battlefield to be a holocaust in which no one can survive. Similarly, the average soldier has no understanding of, or little confidence in, friendly troop safety criteria, and often sees himself victim of his own nuclear fires.

He must be trained in the nature of nuclear weapons effects, what to expect from enemy and friendly weapons, and particularly to have confidence in the predictability of effects and troop safety criteria of his own weapons. He must understand the range and nature of selected effects of tactical nuclear weapons, and he must realize that an individual with whom he has visual contact may be killed by radiation while he can walk away unscathed. He must have confidence in individual and collective

The average soldier has no need for a nuclear physics approach to weapons effects, but he knows that entire elements of his unit can be destroyed by phenomena that he cannot even see, much less understand.

protective measures. He must have confidence in his own ability and that of his unit to safely transport, store, assemble, and fire nuclear weapons.

Normal security measures by units in combat satisfy many of the security requirements of nuclear units. The concepts of OPSEC are fundamental to success and survival of all units in combat operations, and they will habitually be integrated into all appropriate training. Training programs developed for nuclear units *must* include additional security training peculiar to nuclear units. Already discussed in previous chapters, these include:

- Physical security of field storage locations, tactical weapons movements, codes, and authentication systems
- Appropriate security clearances for personnel handling classified information and materiel
- Compliance with provisions of the personnel reliability program

Training must emphasize the *continuing* aspects of *personnel security clearances* and *qualification under the PRP*. Particularly, it must be established that qualification under the PRP is not simply an administrative matter, but a *continuing responsibility* of the *individual himself*, his *peers*, and his *supervisors*.

Chapter 5 lists those operations involving nuclear weapons that are identified as technical operations. These operations are critical to *safety* and *reliability* in that they routinely subject nuclear weapons and components to physical handling, mechanical operations, adjustments, and exposure to ambient environment by unit personnel. This circumstance highlights the importance of individual and team technical training and proficiency.

Using trained individuals, unit commanders will organize and train necessary teams to perform unit nuclear technical operations. Operations should be as *simple*, *direct*, and *austere* as possible. Commanders, particularly of units in direct support, should keep in mind the requirement for *rapid displacement*. There should be absolutely no window dressing — voluminous reference material, facilities, tool displays, or other unnecessary arrangements — in the FSL to complicate or delay unit displacement. Units will *carry*, *secure*, and *maintain* all authorized nuclear training items and materials. *The only requirement is a safe, secure, reliable, nuclear round on time at the target.*

Nuclear technical training for individuals is available at service schools or through on-the-job training in units.

**REFERENCES**

**Army Regulations (AR)**

50-5	Nuclear Surety
50-100 series	Systems Safety Rules
70-39	Criteria for Air-Transport and Air-Drop of Materiel
(C) 105-87	Electronic Warfare (U)
220-58	Organization and Training for Chemical, Biological, and Radiological (CBR) Operations
310-25	Dictionary of United States Army Terms
310-50	Authorized Abbreviations and Brevity Codes
380-5	Safeguarding Defense Information
380-55	Safeguarding Classified Defense Information in Movement of Persons and Things
385-63	Regulations for Firing Ammunition for Training, Target Practice, and Combat
(0) 700-65	Nuclear Weapons and Nuclear Weapons Materiel

**Field Manuals (FM)**

3-12	Operational Aspects of Radiological Defense
3-15	Nuclear Accident Contamination Control
3-22	Fallout Prediction
5-26	Employment of Atomic Demolition Munitions (ADM)
(C) 5-26A	Employment of Atomic Demolition Munitions (ADM) (U)
6-20	Fire Support Coordination
9-6	Ammunition Service in the Theater of Operations
9-47	Special Ammunition Unit Operations
21-40	Chemical, Biological, Radiological, and Nuclear Defense
31-85	Rear Area Protection (RAP) Operations
(C) 32-5	Signal Security (SIGSEC) (U)
(C) 32-20	Electronic Warfare (Ground Base) (U)
44-1	US Army Air Defense Artillery Employment
(S) 44-1A	US Army Air Defense Artillery Employment (U)
55-30	Army Motor Transport Operations
55-XXX series	Air Transport Procedures
100-5	Operations
101-10 series	Staff Officers' Field Manual: Staff Organization and Procedures
101-31-1	Staff Officers' Field Manual: Nuclear Weapons Employment, Doctrine and Procedures



**Technical Manuals (TM)**

3-220	Chemical, Biological, and Radiological (CBR) Decontamination
9-11xx series	Systems Manuals
9-1300-203	Artillery Ammunition
9-1300-206	Care, Handling, Preservation, and Destruction of Ammunition
39-0-1A	Numerical Index to Joint Atomic Weapons Publications
39-25-1	Nuclear Weapons Technical Inspection System
(C) 39-50-8	Emergency Destruction of Nuclear Weapons (U)
39-100-1	Supply Management of Nuclear Weapons Materiel

**Department of the Army  
Pamphlets (DA Pam)**

39-3	The Effects of Nuclear Weapons
310-3	Military Publications: Index of Doctrinal, Training, and Organizational Publications

## STANDARDIZATION AGREEMENT (STANAG) NO. 2104

Standardization Agreements (STANAG) are international (NATO) agreements designed to facilitate interallied operations. Upon ratification by the United States, a STANAG is binding upon US Army Forces (entirely or with exceptions as noted). Following is STANAG No. 2104, as amended in its entirety.

NATO—UNCLASSIFIED  
DETAILS OF AGREEMENT (DofA)  
FRIENDLY NUCLEAR STRIKE WARNING TO ARMED  
FORCES OPERATING ON LAND

### AGREEMENT

It is agreed that the NATO Armed Forces will adopt the following system of friendly nuclear strike warnings for use at corps level and below. This applies to surface-to-surface and air-to-surface strikes in support of ground forces, and to emplaced atomic demolition munitions (ADMs).

### GENERAL

The requirement for a standard warning message and delineation of notification channels is essential to ensure that timely warning of friendly nuclear strikes is provided so that Armed Forces personnel may take individual measures to protect themselves.

### WARNING RESPONSIBILITIES

- a. Responsibility for issuing the warning rests with the executing Commander.
- b. Commanders authorized to release nuclear strikes will ensure that strikes affecting the safety of adjacent or other commands are coordinated with those commands in sufficient time to permit dissemination of warnings to Armed Forces personnel and the taking of protective measures. Conflicts must be submitted to the next higher Commander for decision.

### DETERMINATION OF HEADQUARTERS, FORMATIONS/ UNITS TO BE WARNED

- a. The Commander responsible for issuing the warning should inform:
  - (1) Subordinate Headquarters whose units are likely to be affected by the strike.
  - (2) Adjacent Headquarters whose units are likely to be affected by the strike.
  - (3) Own next higher Headquarters, when units not under the command of the releasing Commander are likely to be affected by the strike.
- b. Each Headquarters receiving a warning of nuclear attack will warn subordinate elements of the safety measures they should take, in the light of their proximity to the Desired Ground Zero (DGZ).

c. Each unit concerned, down to the lowest level, will be warned by its next higher level of the safety measures it should take.

(1) Negligible risks should normally not be exceeded unless significant advantages will be gained.

(2) Maximum protection denotes that Armed Forces personnel are in "buttoned-up" tanks or crouched in foxholes with improvised overhead shielding.

(3) Minimum protection denotes that Armed Forces personnel are prone on open ground with all skin areas covered with an overall thermal protection at least equal to that provided by a two-layer uniform.

#### ZONES OF WARNING AND PROTECTION REQUIREMENTS FOR FRIENDLY NUCLEAR STRIKES



#### Notes:

1. MSD means Minimum Safe Distance.
2. The MSD is equal to a radius of safety ( $R_s$ ) for the yield, plus a buffer distance ( $d_b$ ) related to the dispersion normal to the weapon system used. When surface bursts are used, the fallout hazard will be considered and appropriate buffer distances included.

APPENDIX B

Radius	Corresponding to	Zone	Requirements
DGZ		1	Evacuation of all Armed Forces personnel (see note).
MDS 1	Limit of negligible risk to warned and protected Armed Forces personnel (see note).	2	Maximum protection. (see note).
MSD 2	Limit of negligible risk* to warned and exposed Armed Forces personnel.	3	Minimum protection. (see note).
MSD 3	Limit of negligible risk* to unwarned and exposed Armed Forces personnel		
More than MSD 3			No protective measures except against dazzle

\*As defined in STANAG 2083.

Note. Commanders will be guided by safety criteria as stated in FM 101-30-1, Staff Officers Field Manual, Nuclear Weapons Employment (or appropriate national manuals with the same criteria).

**WARNING MESSAGES**

Warning messages will include the following information (see STANAG 2103):

**STRIKWARN**

**ALPHA:** Code word indicating nuclear strike (target number).

**DELTA:** Date-time group for time of burst in ZULU time. The time after which the strike will be cancelled (ZULU time).

**FOXTROT:** DGZ (UTM grid co-ordinates).

**HOTEL:** Indicate air or surface bursts.

**INDIA:** For all bursts:

MSD 1 in hundreds of meters, four (4) digits

MSD 2 in hundreds of meters, four (4) digits

MSD 3 in hundreds of meters, four (4) digits

**YANKEE:** For all bursts when there is less than a 99 percent assurance of no militarily significant fallout. Direction measured clockwise from grid north to the left and then to the right radial lines (degrees or mils — state which) four (4) digits each.

**ZULU:** For all bursts when there is less than a 99 percent assurance of no militarily significant fallout. Effective wind speed in kilometers per hour, three (3) digits. Downwind distance of Zone 1 (km), three (3) digits. Cloud radius (km), two (2) digits.

**EXAMPLE MESSAGES**

FOR ALL BURSTS WITH 99 PERCENT ASSURANCE OF NO MILITARILY SIGNIFICANT FALLOUT STRIKWARN. ALPHA TUBE SIX.

DELTA PQ WM OT AR/AS DG WY OF. FOXTROT YM AB IM SK. HOTEL AIR. INDIA 0022 0031 0045. FOR ALL BURSTS WITH LESS THAN 99 PERCENT ASSURANCE OF NO MILITARILY SIGNIFICANT FALLOUT STRIKWARN. ALPHA TUBE SIX. DELTA PQ WM OT AR/AS DG WY OF. FOXTROT YM AB IM SK. HOTEL SURFACE. INDIA 0022 0031 0045. YANKEE 0215 0255 DEGREES. ZULU 025 080 18.

#### IMPENDING STRIKE WARNING

Warning of impending strikes will be initiated no earlier than is necessary to complete warning of Armed Forces personnel. Any available means of communications — land lines if possible — will be utilized to ensure that all Armed Forces personnel requiring warning are notified.

#### ACTION ON CANCELLED STRIKES

When nuclear strikes are cancelled, units previously warned will be notified in the clear by the most expeditious means in the following format:

- a. Code Word (Target Number)
- b. CANCELLED

#### USE OF CODES

- a. Items DELTA and FOXTROT above will not be sent in clear unless the time of initiating the warning message is such that no loss of security is involved.
- b. Only coding systems which meet NATO security criteria will be used.

#### OTHER WARNINGS

a. It is recognized that it is impractical to obtain warnings of surface-to-air (for instance, air defense) nuclear burst which may occur at low altitudes, and to disseminate such warnings to Armed Forces personnel.

b. Similarly, it may be impractical to provide warning to the Naval and Air Forces concerned of intended surface-to-surface strikes delivered by weapons within the corps, especially for fleeting targets or when reaction times are short. Nevertheless, it is the responsibility of Army agencies to provide warning to Naval and Air Forces concerned whenever possible.

#### IMPLEMENTATION OF THE AGREEMENT

a. This STANAG will be considered to have been implemented when the necessary orders/instructions putting the procedures detailed in this agreement into effect have been issued to the forces concerned.

b. Related Documents.

- (1) STANAG 2083 — Radiological Hazards.
- (2) STANAG 2099 — Fire Coordination in the Land/Air Battle.
- (3) STANAG 2103 — Reporting Nuclear Detonations, Radioactive Fallout and Biological and Chemical Attacks.

**FM 100-50**

**31 MARCH 1977**

By Order of the Secretary of the Army:

**BERNARD W. ROGERS**  
*General, United States Army*  
*Chief of Staff*

Official:

**PAUL T. SMITH**  
*Major General, United States Army*  
*The Adjutant General*

**DISTRIBUTION:**

*Active Army, USAR, and ARNG:* To be distributed in accordance with DA Form 12-11A, Requirements for Aviation Co, Bn, Gp and Brigade (Qty rqr block no. 3); Employment of Atomic Demolition Munitions (ADM) (Qty rqr block no. 23); Field Artillery Tactics (Qty rqr block no. 39); Special Ammunition Unit Operations (Qty rqr block no. 93); The Armored Cavalry Regiment (Qty rqr block no. 133); plus: DA Form 12-11B, Requirements for Tactical Nuclear Operations (Qty rqr block no. 411); and DA Form 12-35 (1 copy each account).

Additional copies can be requisitioned (DA Form 17) from the US Army Adjutant General Publications Center, 2800 Eastern Boulevard, Baltimore, MD 21220.



FM 100-50