

5
55-218

MHI
Copy 2

SIS BY SAME
DTD 20 FEB 79

FM 55-218

FIELD MANUAL

AIR TRANSPORT PROCEDURES
TRANSPORT OF 8-INCH
ATOMIC PROJECTILES, M422
BY US ARMY HELICOPTERS

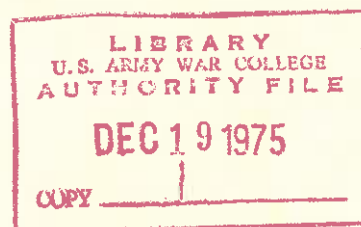

HEADQUARTERS, DEPARTMENT OF THE ARMY
NOVEMBER 1975

FIELD MANUAL }
No. 55-218 }

HEADQUARTERS
DEPARTMENT OF THE ARMY
WASHINGTON, D.C. 28 November 1975

**AIR TRANSPORT PROCEDURES
TRANSPORT OF 8-INCH ATOMIC PROJECTILE, M422
BY US ARMY HELICOPTERS**

	Paragraph	Page
Purpose and scope	1	1
Reporting of publication improvements	2	1
General safety and security considerations	3	1
Air transportability and handling data	4	2
Internal transport	5	3
External transport	6	16
APPENDIX A. REFERENCES		21
B. Conversion Tables		23

o✓ *o✓*
*This manual supersedes TM 55-1100-218-12-3, 24 November 1971, and TM 55-1100-218-12-12, 31 March 1971.

1. Purpose and Scope

a. This manual presents Department of the Army approved procedures for internal and external transport of the 8-inch atomic projectile, M422 (also referred to as "projectile"), by US Army helicopters. This manual pertains to the UH-1-series, CH-47, and CH-54 helicopters. Materials and qualified manpower needed to prepare, load, tie down, and unload or rig and derig the projectile components are prescribed herein. Where appropriate, metric equivalents are given in parentheses following the dimension of other measurement. Conversion tables are contained in appendix B. References are shown in appendix A.

b. The procedures in this manual apply when the projectile, in either the stockpile storage configuration or the assembled storage configuration, is transported by the above identified helicopters. The described loads are not maximum helicopter loads. Additional internal cargo, including different types of nuclear weapons and/or personnel within allowable load limits and restrictions prescribed by AR 50-5 and pertinent safety regulations (app), may be transported.

c. Times given to prepare, load, tie down, and unload or rig and derig the loads described in this manual may vary, dependent upon existing conditions.

2. Reporting of Publication Improvements

The reporting of errors, omissions, and recommendations for improving this publication by the individual user is encouraged. Reports should be submitted on DA Form 2028 (Recommended Changes to Publications and Blank Forms) and forwarded to Director, Military Traffic Management Command Transportation Engineering Agency, ATTN: MTT-TRP, PO Box 6276, Newport News, VA 23606.

3. General Safety and Security Considerations

WARNING

The projectile, M422, components are not to be jettisoned under any circumstances.

a. The following warnings will be observed by personnel performing operations, procedures, and practices that are included or implied in this manual. Disregard of these warnings could result in personal injury or loss of life.

(1) Prior to each nuclear cargo mission, the helicopter commander will familiarize himself with the provisions of AR 50-5 and insure compliance therewith. In addition, he will become familiar with the security, safety, and technical

peculiarities of the cargo that may affect air transport. Flight plans should avoid populated areas to the maximum extent possible. When transporting the projectile components in the universal military pod by CH-54 helicopter, the pod must be secured to the helicopter to preclude jettisoning the pod deliberately or inadvertently. Procedures for securing the pod to preclude jettisoning are prescribed in paragraphs 13-5 and 13-6 of TM 55-1520-217-10/1 or in paragraphs 13-3 and 13-4 or TM 55-1520-217-10/2.

(2) There are minimum spacing separations for projectile components in the shipping containers, M102, and on the projectile in the assembled storage configuration. As a general rule, maintain 3 feet (0.9 meter) center-to-center spacing. If spacing is a problem, consult TM 9-1100-218-20 and TM 39-45-51A for more detailed information.

(3) To determine compatibility of any other nuclear weapons or other cargo as authorized in chapter 4, AR 50-5, for transport with the projectile components, ordnance support channels must be consulted. Information on compatibility is contained in TM 39-45-51C and TM 38-250, which are distributed to major headquarters and direct support and general support levels. Restrictions listed in TM 39-20-7 will not be exceeded when additional types of nuclear weapons are transported along with the projectile components.

(4) Emergency destruction procedures for the projectile components will be accomplished in accordance with TM 39-50-8. Normally, emergency destruct materials will not be carried on the same aircraft as nuclear weapons. In the isolated case where operational necessity limits the availability of alternate aircraft, the theater commander may authorize emergency destruct materials (including blasting caps) to be transported in the load-carrying aircraft. Such materials will be properly packaged, isolated from weapons as far as possible, and tied down so as to prevent movement. Only the number of destruct charges and blasting caps necessary to destroy the projectile components will be carried aboard. Blasting caps in their container will be stored separately and surrounded by a sandbag barrier.

(5) The projectile components will be loaded and tied down in accordance with the procedures in this manual except that they may be repositioned for helicopter operational reasons, or when loading additional nuclear weapons or other cargo and/or personnel. If a location other than that shown in the respective tiedown diag-

ram is used, the helicopter commander must insure that —

(a) The shipping containers, M102, and the projectile in the assembled storage configuration are separated at all times by at least 3 feet (0.9 meter) (center-to-center spacing).

(b) The number and load capacity of the tiedown devices are as prescribed in this manual.

(c) The tiedown devices restraining the projectile components are secured to tiedown fittings in the same location relative to the components as those fittings used in the pertinent tiedown diagram.

(d) The projectile components face as shown in the pertinent tiedown diagram.

b. The following operational precautions will be observed during loading, rigging, tiedown, transport, and unloading of the projectile components.

(1) Web strap tiedown assemblies and cargo slings, as used to secure or sling-transport the items described in this manual, are limited to a maximum time of usage (useful life) of 36 months. The time of usage will commence at the time the tiedowns and slings are unpackaged for use by the using organization. At that time they will be marked using stencil ink TT-I-559 (any contrasting color) with the current date (month and year) in at least ½-inch-high letters.

(2) Prior to each usage, tiedowns and slings will be inspected for tears, punctures, or cuts. Additionally, metal items will be inspected for improper operation, corrosion, cracks, or distortion. If any of these conditions are present, or if the time of usage exceeds 36 months, the tiedowns or slings must be replaced. No testing of tiedowns or slings will be conducted. Additional storage, inspection, and maintenance criteria for tiedowns and slings are prescribed by 55-450-series technical manuals (app A).

(3) When attaching tiedown devices to cargo and to tiedown fittings, approximately equal tension must be maintained throughout tiedown arrangements. Tiedowns must be checked during flight and tightened as necessary.

(4) Security and safety measures relative to guards, fire, or emergency destruction procedures, as established by pertinent publications (app A), will be observed during all phases of air transport. All operations described herein will be in strict compliance with AR 50-103, TM 9-1300-206, and TM 9-1100-218-20.

(5) The danger areas around helicopters must be cleared of personnel, other aircraft, vehicles, and loose objects including trash, before the engines are started.

(6) The high noise level of helicopter engines can cause permanent damage to the human ear. All personnel working in the vicinity will wear hearing protectors and avoid entering engine noise danger area. In addition, external cargo hookup personnel will wear goggles and protective headgear (hard hat, steel helmet, or flight helmet).

4. Air Transportability and Handling Data

a. Air transport load configurations of the 8-inch atomic projectile, M422, are as follows:

(1) Configuration I (stockpile storage configuration: four filled containers).

(2) Configuration II (assembled storage configuration: two filled containers).

NOTE

The 8-inch atomic projectile, M422, in the assembled storage configuration (configuration II), is air transportable only when the conditions described in paragraph 3c, AR 50-103 prevail. If these conditions occur, procedures in this manual will be followed.

b. Identification, dimensions, and approximate weight of containers comprising configurations I and II are shown in figure 1 and table 1.

c. Personnel dosimetry (film badge) or special radiological handling procedures are not required, unless otherwise specified, for personnel engaged in operations described in this manual.

d. The carrying case, M102, with sidearm, is

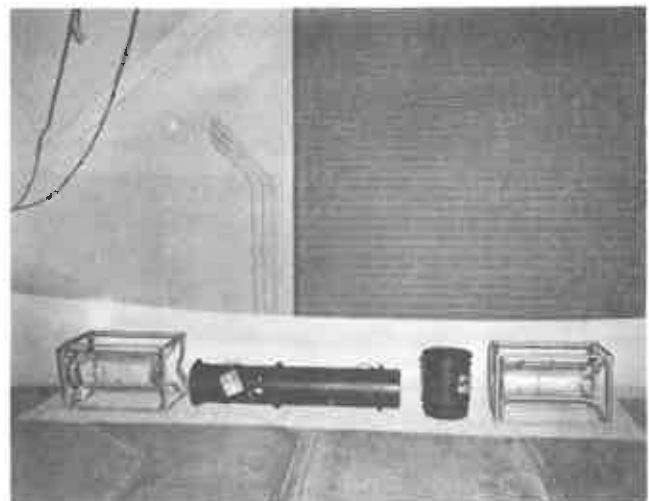

Figure 1. Containers for the 8-inch atomic projectile, M422, configuration I. The two center containers comprise configuration

II.

Table 1. Dimensions and Weight of Containers for 8-Inch Atomic Projectile, M422

Identification	Dimensions			Diameter	Weight
	Length	Width	Height		lb (kg)
Configuration I:					
Projectile, M422, in projectile case, M500 ----	49.5 in. (1.26 m)	--	--	11.5 in. (0.29 m)	160 lb (73 kg)
Carrying case, M102, with sidearm -----	16.0 in. (0.41 m)	16.0 in. (0.41 m)	25.0 in. (0.64 m)	--	230 lb (104 kg)
Accessory parts case (AN can) -----	--	--	15.0 in. (0.38 m)	12.0 in. (0.30 m)	28 lb (13 kg)
Carrying case, M102 -----	16.0 in. (0.41 m)	16.0 in. (0.41 m)	25.0 in. (0.64 m)	--	185 lb (81 kg)
Container, H1343 (TZ)* -----	23.5 in. (0.60 m)	23.5 in. (0.60 m)	26.0 in. (0.66 m)	--	275 lb (126 kg)
Container, H1343 (PZ and PW)* -----	23.5 in. (0.60 m)	23.5 in. (0.60 m)	26.0 in. (0.66 m)	--	195 lb (92 kg)
Configuration II:					
Projectile, M422, with permissive action link (PAL) in projectile case, M500 -----	49.5 in. (1.26 m)	--	--	11.5 in. (0.29 m)	330 lb** (150 kg)
Accessory parts case (AN can) -----	--	--	15.0 in. (0.38 m)	12.0 in. (0.30 m)	24 lb (11 kg)

*The respective containers, H1343, will eventually replace the carrying case, M102, with sidearm and the carrying case, M102.

**Weight without PAL is 300 pounds (136 kg).

distinguished from the carrying case, M102, by the small receptacle (sidearm) mounted on the side of its storage cylinder. The space interval separating the carrying cases must be no less than the minimum distance prescribed by TM 39-20-7.

e. Items comprising the load configurations must be inspected for damage other than minor scratches and abrasions. If any item is damaged to such an extent that its contents or functions are believed to be affected, notify the support unit and submit a report in accordance with chapter 5, AR 50-5, if appropriate.

f. Covers/lids on all containers must be secured.

g. When transporting the projectile in the assembled storage configuration, all associated containers, empty or otherwise, will accompany the projectile case and the accessory parts case. The associated containers (carrying cases, M102 and containers, H1343) will be tied down as prescribed for the stockpile storage configuration.

5. Internal Transport

NOTE

Tiedown diagrams for the 8-inch atomic projectile, M422, depict the carrying cases, M102, which will be replaced by containers, H1343. The containers, H1343, will be positioned at locations shown in the diagrams for the

carrying cases, M102, and tied down as prescribed in *b* below.

a. Transport of configuration I (stockpile storage configuration: four containers).

(1) *Materials*. Parking shoring: Plywood, one piece, 1- by 5-foot by 1-inch, or equivalent, for use under the projectile case, M500; plywood, one piece, 1- by 2-foot by 1-inch, or equivalent, for use under accessory parts case.

WARNING

Insure that the universal military pod is secured to the CH-54 helicopter to preclude jettisoning the pod either deliberately or inadvertently.

(2) *Loading*.

(a) Manhandle containers into helicopter or universal military pod, and position at tiedown location. Center projectile case, M500, and accessory parts case on shoring. Four men can prepare, load, and tie down the four containers in approximately 20 minutes.

(b) Tie down the containers in the respective helicopter or pod in accordance with the following:

Helicopter	Figure	Table
CH-47	2	2
UH-1C/M*	3	3
UH-1D/H	4	4
CH-54 (universal military pod)	5	5

*Cargo-floor-fitting pattern in the UH-1B helicopter is similar to the fitting pattern for the UH-1C/M helicopters. Strength of floor fittings in the UH-1B/C/M helicopters are the same.

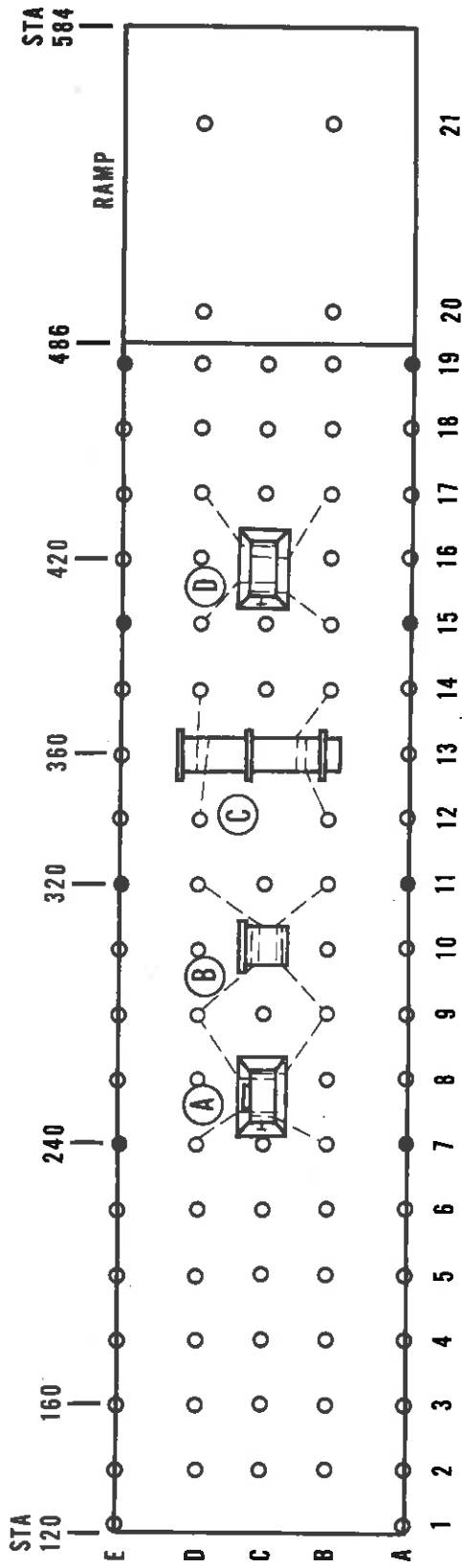

○ 5000 LB TIEDOWN FITTING ● 10000 LB TIEDOWN FITTING

NOTE: UTILITY HATCH DOOR IS LOCATED IN THE CENTER OF THE FLOOR BETWEEN STATIONS 320 AND 360.

ITEM	DESCRIPTION OF ITEM	ITEM FACING	LOCATION OF REFERENCE POINT		LOCATION OF APPROX CG (STA)	APPROX WT (LB)
			REFERENCE POINT	STATION		
(A)	CARRYING CASE, M102, WITH SIDEARM	TOP FORWARD	FORWARD EDGE	244	257	230
(B)	ACCESSORY PARTS CASE (AN CAN)	TOP RIGHT	FORWARD EDGE	294	300	28
(C)	PROJECTILE, M422, IN PROJECTILE CASE, M500	TOP RIGHT	FORWARD EDGE	354	360	160
(D)	CARRYING CASE, M102	TOP FORWARD	FORWARD EDGE	406	419	135

Figure 2. Tiedown diagram for 8-inch atomic projectile, M102, configuration I (stockpile storage configuration), in CH-47 helicopter.

Table 2. Tiedown Data for 8-Inch Atomic Projectile, M422, Configuration I (Stockpile Storage Configuration), in CH-47 Helicopter

Item	Tiedown fitting		Tiedown device*		Attach to item
	designation	capacity in 1,000 lb	type	capacity in 1,000 lb	
A	B7/D7	5	CGU-1/B	5	Loop over and around inner frame.
	B9/D9	5	CGU-1/B	5	Loop over and around inner frame.
B	B9/B11	5	CGU-1/B	5	One turn over and around the container above the lower ring roll.
	D9/D11	5	CGU-1/B	5	One turn over and around the container between the chime and upper ring roll.
C	B12/B14	5	CGU-1/B	5	One turn over and around the container.
	D12/D14	5	CGU-1/B	5	One turn over and around the container.
D	B15/D15	5	CGU-1/B	5	Loop over and around inner frame.
	B17/D17	5	CGU-1/B	5	Loop over and around inner frame.

*MC-1 tiedown device may be used.

Table 3. Tiedown Data for 8-Inch Atomic Projectile, M422, Configuration I (Stockpile Storage Configuration), in UH-1C/M Helicopters

Item	Tiedown fitting		Tiedown device*		Attach to item
	designation	capacity in 1,000 lb	type	capacity in 1,000 lb	
A	A1/C3	1.25	CGU-1/B	5	One turn over and around the container.
	A2/C4	1.25	CGU-1/B	5	One turn over and around the container.
B	E2/E3	1.25	CGU-1/B	5	Loop over and around inner frame.
	G2/G3	1.25	CGU-1/B	5	Loop over and around inner frame.
C	E3/E4	1.25	CGU-1/B	5	One turn over and around the container above the lower ring roll.
	G3/G4	1.25	CGU-1/B	5	One turn over and around the container between the chime and upper ring roll.
D	E4/E6	1.25	CGU-1/B	5	Loop over and around inner frame.
	G4/G5	1.25	CGU-1/B	5	Loop over and around inner frame.

*MC-1 tiedown device may be used.

Table 4. Tiedown Data for 8-Inch Atomic Projectile, M422, Configuration I (Stockpile Storage Configuration), in UH-1D/H Helicopters

Item	Tiedown fitting		Tiedown device*		Attach to item
	designation	capacity in 1,000 lb	type	capacity in 1,000 lb	
A	B3/D3	1.25	CGU-1/B	5	One turn over and around the container.
	B5/D5	1.25	CGU-1/B	5	One turn over and around the container.
B	F1/F2	1.25	CGU-1/B	5	Loop over and around inner frame.
	J1/K2	1.25	CGU-1/B	5	Loop over and around inner frame.
C	G1/G2	1.25	CGU-1/B	5	One turn over and around the container above the lower ring roll.
	J3/J4	1.25	CGU-1/B	5	One turn over and around the container between the chime and upper ring roll.
D	F4/F5	1.25	CGU-1/B	5	Loop over and around inner frame.
	J6/K3	1.25	CGU-1/B	5	Loop over and around inner frame.

*MC-1 tiedown device may be used.

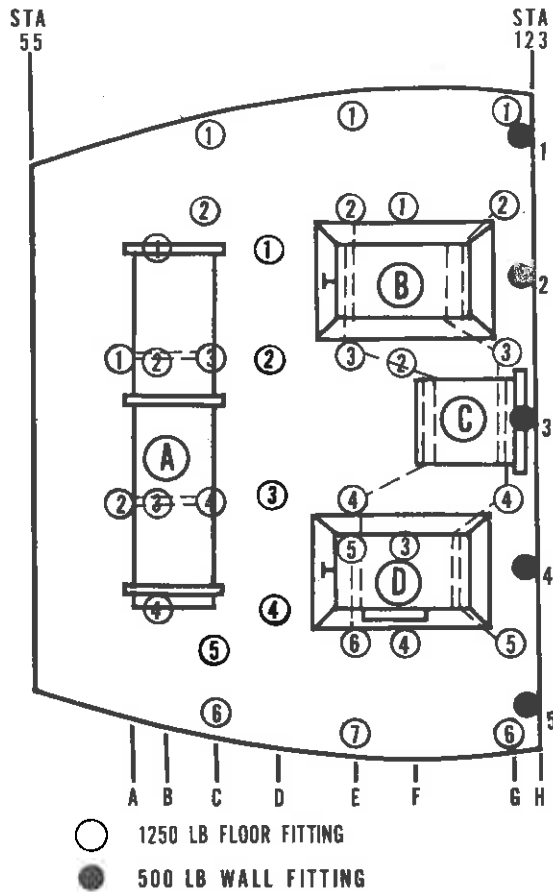

ITEM	DESCRIPTION OF ITEM	ITEM FACING	LOCATION OF REFERENCE POINT		LOCATION OF CG (STA)	APPROX WT (LB)
			REFERENCE POINT	STATION		
(A)	PROJECTILE, M422, IN PROJECTILE CASE, M500	TOP RIGHT	FORWARD EDGE	69	75	160
(B)	CARRYING CASE, M102	TOP FORWARD	FORWARD EDGE	93	106	135
(C)	ACCESSORY PARTS CASE (AN CAN)	TOP AFT	FORWARD EDGE	104	112	28
(D)	CARRYING CASE, M102, WITH SIDEARM	TOP FORWARD	FORWARD EDGE	93	106	230

Figure 3. Tiedown diagram for 8-inch atomic projectile, M422, configuration I (stockpile storage configuration), in UH-1C/M helicopters.

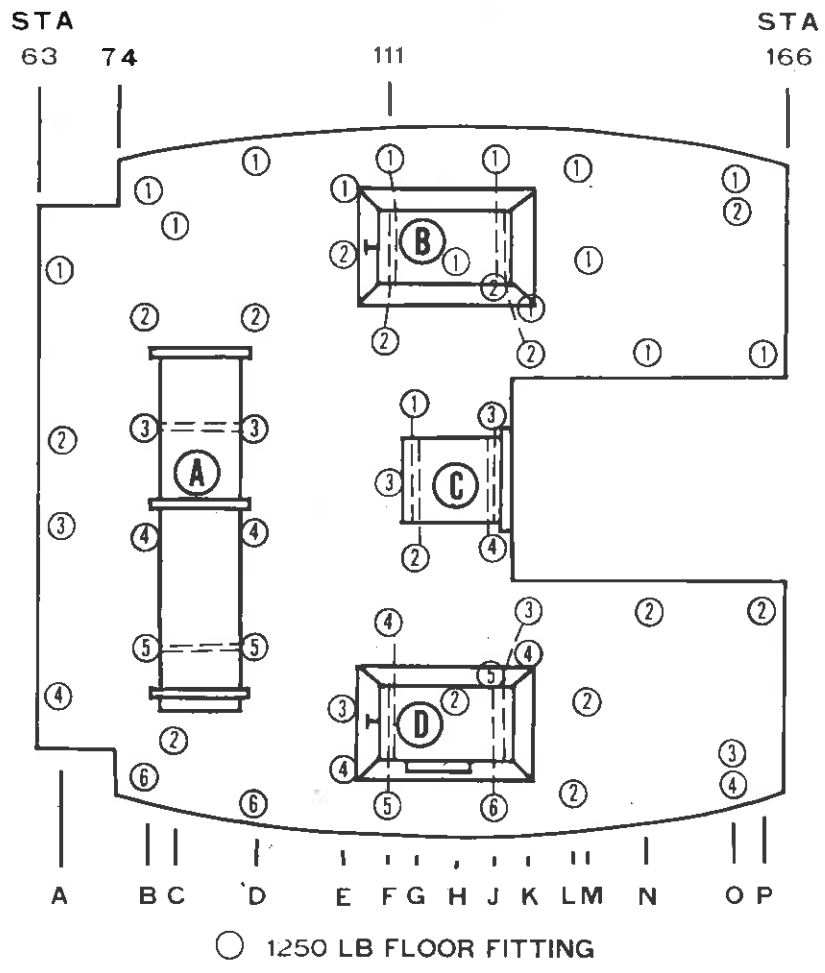

ITEM	DESCRIPTION OF ITEM	ITEM FACING	LOCATION OF REFERENCE POINT		LOCATION OF CG (STA)	APPROX WT (LB)
			REFERENCE POINT	STATION		
Ⓐ	PROJECTILE, M422, IN PROJECTILE CASE, M500	TOP RIGHT	FORWARD EDGE	80	86	160
Ⓑ	CARRYING CASE, M102	TOP FORWARD	FORWARD EDGE	107	120	135
Ⓒ	ACCESSORY PARTS CASE (AN CAN)	TOP AFT	FORWARD EDGE	113	121	28
Ⓓ	CARRYING CASE, M102, WITH SIDEARM	TOP FORWARD	FORWARD EDGE	107	120	230

Figure 4. Tiedown diagram for 8-inch atomic projectile, M422, configuration I (stockpile storage configuration), in UH-1D/H helicopters.

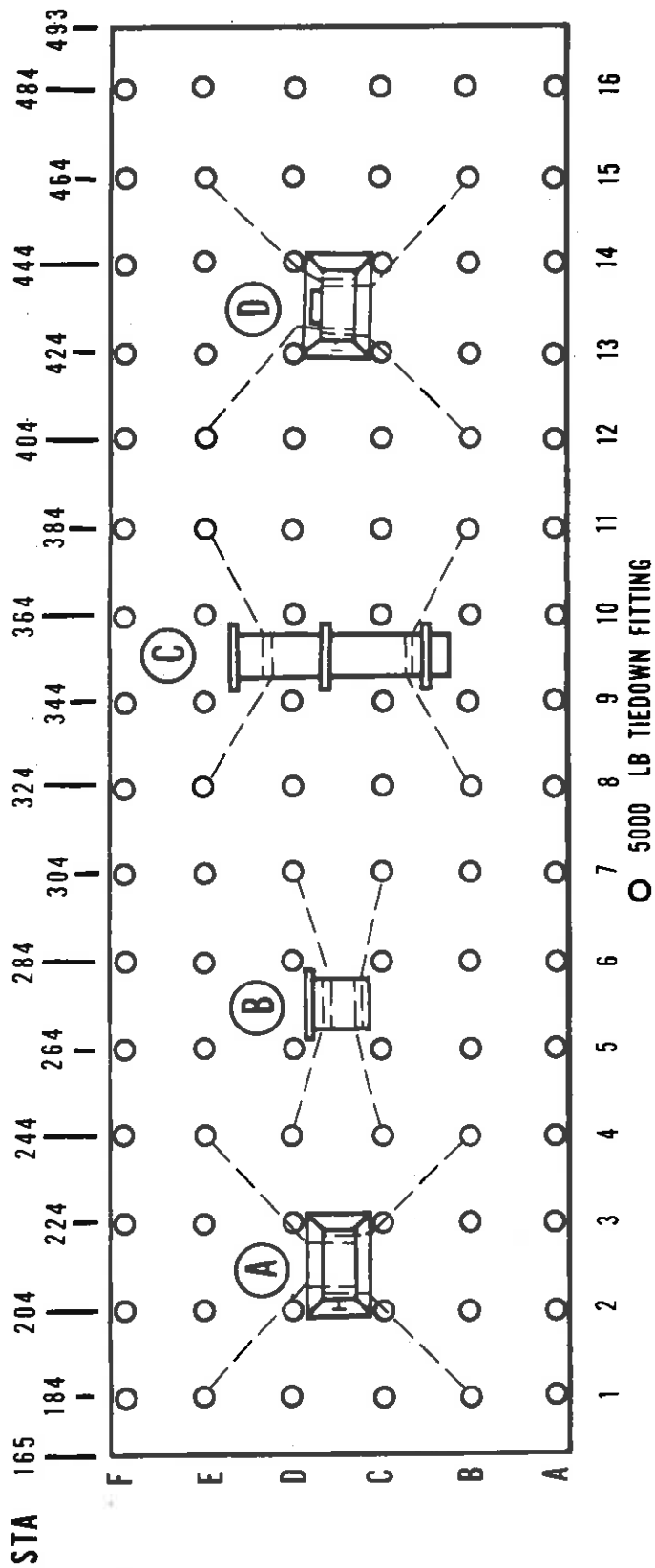

ITEM	DESCRIPTION OF ITEM	ITEM FACING	LOCATION OF REFERENCE POINT		LOCATION OF CG (STA)	APPROX WT (LB)
			REFERENCE POINT	STATION		
(A)	CARRYING CASE, M102	TOP FORWARD	FORWARD EDGE	200	213	135
(B)	ACCESSORY PARTS CASE (AN CAN)	TOP RIGHT	FORWARD EDGE	268	274	28
(C)	PROJECTILE, M422, IN PROJECTILE CASE, M500	TOP RIGHT	FORWARD EDGE	348	354	160
(D)	CARRYING CASE, M102, WITH SIDEARM	TOP FORWARD	FORWARD EDGE	420	433	230

Figure 5. Tiedown diagram for 8-inch atomic projectile, M422, configuration I (stockpile storage configuration), in CH-54 helicopter universal military pod.

Table 5. Tiedown Data for 8-Inch Atomic Projectile, M422, Configuration I (Stockpile Storage Configuration), in CH-54 Helicopter Universal Military Pod

Item	Tiedown fitting		Tiedown device*		Attach to item
	designation	capacity in 1,000 lb	type	capacity in 1,000 lb	
A	B1/E1	5	CGU-1/B	5	Loop over and around inner frame.
	B4/E4	5	CGU-1/B	5	Loop over and around inner frame.
B	C4/C7	5	CGU-1/B	5	One turn over and around the container above the lower ring roll.
	D4/D7	5	CGU-1/B	5	One turn over and around the container between the chime and upper ring roll.
C	B8/B11	5	CGU-1/B	5	One turn over and around the container.
	E8/E11	5	CGU-1/B	5	One turn over and around the container.
D	B12/E12	5	CGU-1/B	5	Loop over and around inner frame.
	B15/E15	5	CGU-1/B	5	Loop over and around inner frame.

*MC-1 tiedown device may be used.

(3) *Unloading.* Four men can unload the four containers from any of the helicopters or the pod in approximately 10 minutes.

b. Transport of two containers, H1343, configuration I (stockpile storage configuration).

WARNING

The container, H1343, must stand on base for storage and shipment. Port-hole on top of container is not to be covered.

(1) *Materials.* Parking shoring: plywood, two pieces, 2- by 2-foot by 1-inch, or equivalent, for use under containers.

(2) *Loading.*

(a) Manhandle containers (fig 6) into helicopter or universal military pod, and position at tiedown location. Center containers on shoring. Four men can prepare, load, and tie down the two containers in approximately 10 minutes.

(b) Tie down the containers in the CH-47 helicopter in accordance with figure 7 and table 6. Use the same tiedown procedures when restraining the containers for transport in the UH-1-series helicopters and in the CH-54 helicopter universal military pod.

(3) *Unloading.* Four men can unload the two containers from any of the helicopters or the pod in approximately 5 minutes.

c. Transport of configuration II (assembled storage configuration-two containers).

WARNING

When in the assembled storage configuration, the projectile, M422, in projectile case, M500, must be separated a minimum of 3 feet (0.9 meter) (center-

to-center spacing) from any other nuclear weapon or nuclear component.

WARNING

When in the assembled storage configuration, the nose of the projectile must be positioned so that it is pointing to the right, left, or rear of the helicopter or pod; never to the front. If container markings do not identify nose of projectile, ordnance support channels must be consulted.

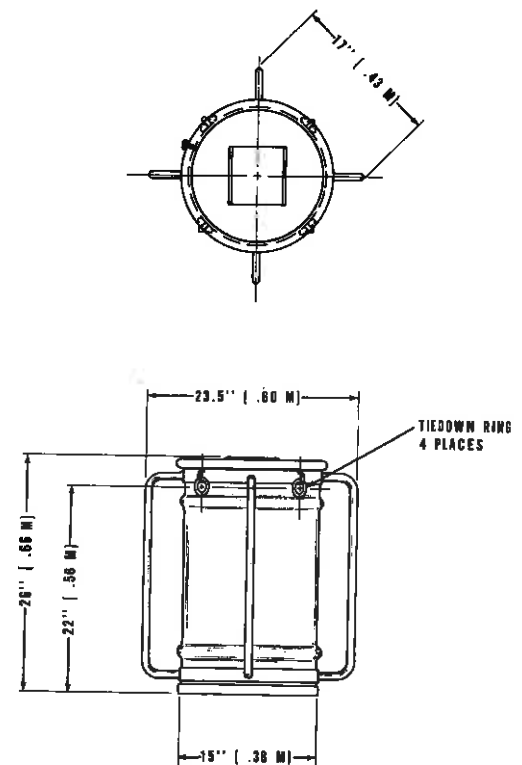
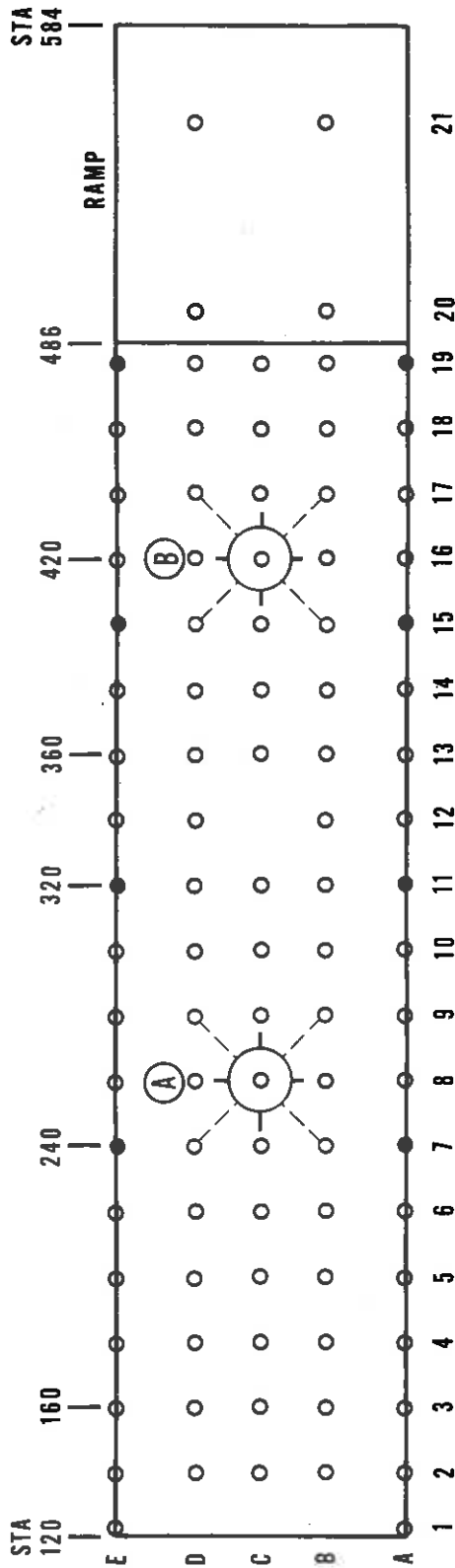
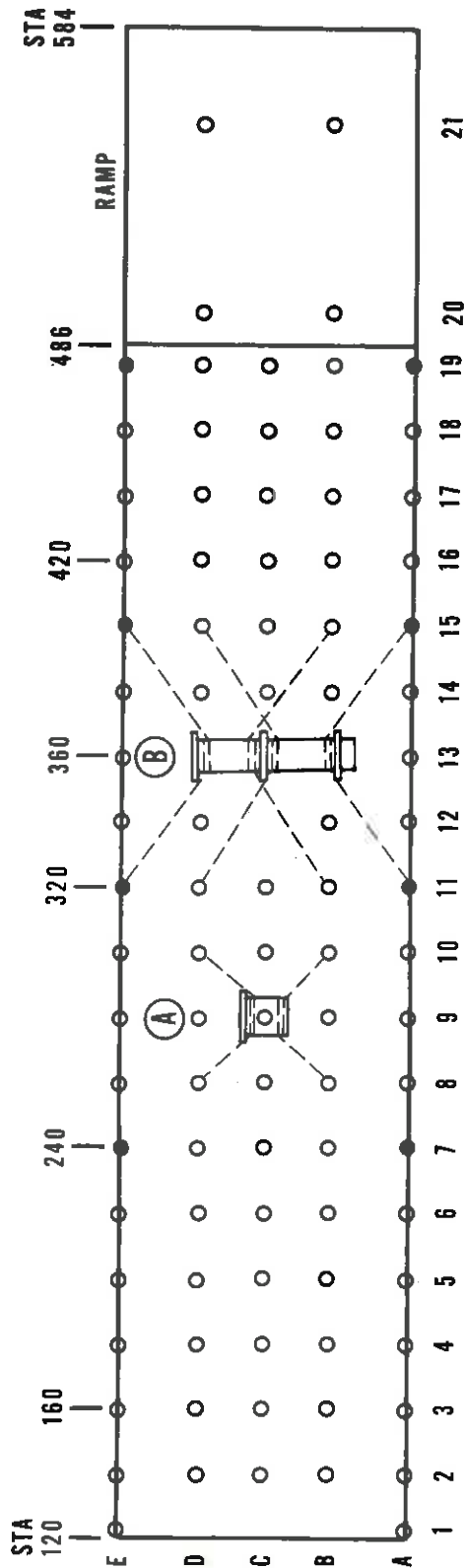

Figure 6. Container, H1343. The container must stand on base as illustrated for storage and shipment.



ITEM	DESCRIPTION OF ITEM	ITEM FACING	LOCATION OF REFERENCE POINT		LOCATION OF APPROX CG (STA)	APPROX WT (LB)
			REFERENCE POINT	STATION		
(A)	CONTAINER, H1343 (TZ)	ON BASE	FORWARD EDGE	248	260	275
(B)	CONTAINER, H1343 (PZ & PW)	ON BASE	FORWARD EDGE	408	420	195

Figure 7. Tiedown diagram for two containers, H1343, configuration 1 (stockpile storage configuration), in CH-47 helicopter.



ITEM	DESCRIPTION OF ITEM	ITEM FACING	LOCATION OF REFERENCE POINT		LOCATION OF APPROX CG (STA)	APPROX WT (LB)
			REFERENCE POINT	STATION		
(A)	ACCESSORY PARTS CASE (AN CAN)	TOP RIGHT	FORWARD EDGE	274	280	24
(B)	PROJECTILE, M422, IN PROJECTILE CASE, M500 [WITH PAL]	TOP RIGHT	FORWARD EDGE	354	360	300
		TOP RIGHT	FORWARD EDGE	354	360	330

Figure 8. Tiedown diagram for 8-inch atomic projectile, M422, configuration II (assembled storage configuration), in CH-47 helicopter.

(1) *Materials.* Parking shoring: plywood, two pieces, 1- by 5-foot by 1-inch, or equivalent, for use under projectile case, M500; plywood, one piece, 1- by 2-foot by 1-inch, or equivalent, for use under accessory parts case.

(2) *Loading.*

(a) Manhandle containers into helicopter or universal military pod, and position at tiedown location. Center projectile case, M500, and accessory parts case on shoring. Four men can prepare, load, and tie down the two containers in approximately 20 minutes.

(b) Tie down the containers in the respective helicopter or pod in accordance with the following:

Helicopter	Figure	Table
CH-47	8	7
UH-1C/M*	9	8
UH-1D/H	10	9
CH-54 (universal military pod).	11	10

*Cargo-floor-fitting pattern in the UH-1B helicopter is similar to the fitting pattern for the UH-1C/M helicopters. Strength of floor fittings in the UH-1B/C/M helicopters are the same.

Table 6. Tiedown Data for Two Containers, H1343, Configuration I (Stockpile Storage Configuration), in CH-47 Helicopter

Item	Tiedown fitting		Tiedown device*		Attach to item
	designation	capacity in 1,000 lb	type	capacity in 1,000 lb	
A	B7	5	CGU-1/B	5	Left front tiedown ring
	D7	5	CGU-1/B	5	Right front tiedown ring
	B9	5	CGU-1/B	5	Left rear tiedown ring
	D9	5	CGU-1/B	5	Left rear tiedown ring
	D9	5	CGU-1/B	5	Right rear tiedown ring
B	B15	5	CGU-1/B	5	Left front tiedown ring
	D15	5	CGU-1/B	5	Right front tiedown ring
	B17	5	CGU-1/B	5	Left rear tiedown ring
	D17	5	CGU-1/B	5	Right rear tiedown ring

*MC-1 tiedown device may be used.

Table 7. Tiedown Data for 8-Inch Atomic Projectile, M422, Configuration II (Assembled Storage Configuration), in CH-47 Helicopter

Item	Tiedown fitting		Tiedown device*		Attach to item
	designation	capacity in 1,000 lb	type	capacity in 1,000 lb	
A	B8/B10	5	CGU-1/B	5	One turn over and around the container above the lower ring roll.
	D8/D10	5	CGU-1/B	5	One turn over and around the container between the chime and upper ring roll.
B	A11/A15	10	CGU-1/B	5	One turn over and around the container.
	B11/B15	5	CGU-1/B	5	One turn over and around the container above the center ring roll.
	D11/D15	5	CGU-1/B	5	One turn over and around the container below the center ring roll.
	E11/E15	10	CGU-1/B	5	One turn over and around the container.

*MC-1 tiedown device may be used.

Table 8. Tiedown Data for 8-Inch Atomic Projectile, M422, Configuration II (Assembled Storage Configuration), in UH-1C/M Helicopters

Item	Tiedown fitting		Tiedown device*		Attach to item
	designation	capacity in 1,000 lb	type	capacity in 1,000 lb	
A	B1/D1	1.25	CGU-1/B	5	One turn over and around the container.
	B2/D2	1.25	CGU-1/B	5	One turn over and around the container.
	A1/E3	1.25	CGU-1/B	5	One turn over and around the container below the center ring roll.
	A2/E4	1.25	CGU-1/B	5	One turn over and around the container above the center ring roll.
B	B3/D3	1.25	CGU-1/B	5	One turn over and around the container.
	B4/D4	1.25	CGU-1/B	5	One turn over and around the container.
	E3/G3	1.25	CGU-1/B	5	One turn over and around the container between the chime and upper ring roll.
	E4/G4	1.25	CGU-1/B	5	One turn over and around the container above the lower ring roll.

*MC-1 tiedown device may be used.

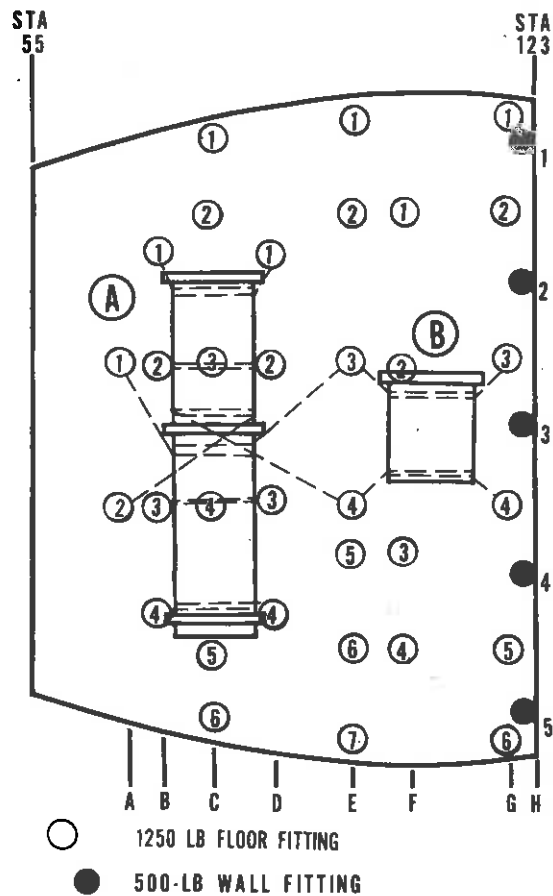

ITEM	DESCRIPTION OF ITEM	ITEM FACING	LOCATION OF REFERENCE POINT		LOCATION OF CG (STA)	APPROX WT (LB)
			REFERENCE POINT	STATION		
(A)	PROJECTILE, M422, IN PROJECTILE CASE, M500 (WITH PAL)	TOP RIGHT	FORWARD EDGE	74	80	300
(B)	ACCESSORY PARTS CASE (AN CAN)	TOP RIGHT	FORWARD EDGE	103	109	24

Figure 9. Tiedown diagram for 8-inch atomic projectile, M422, configuration II (assembled storage configuration), in UH-1C/M helicopters.

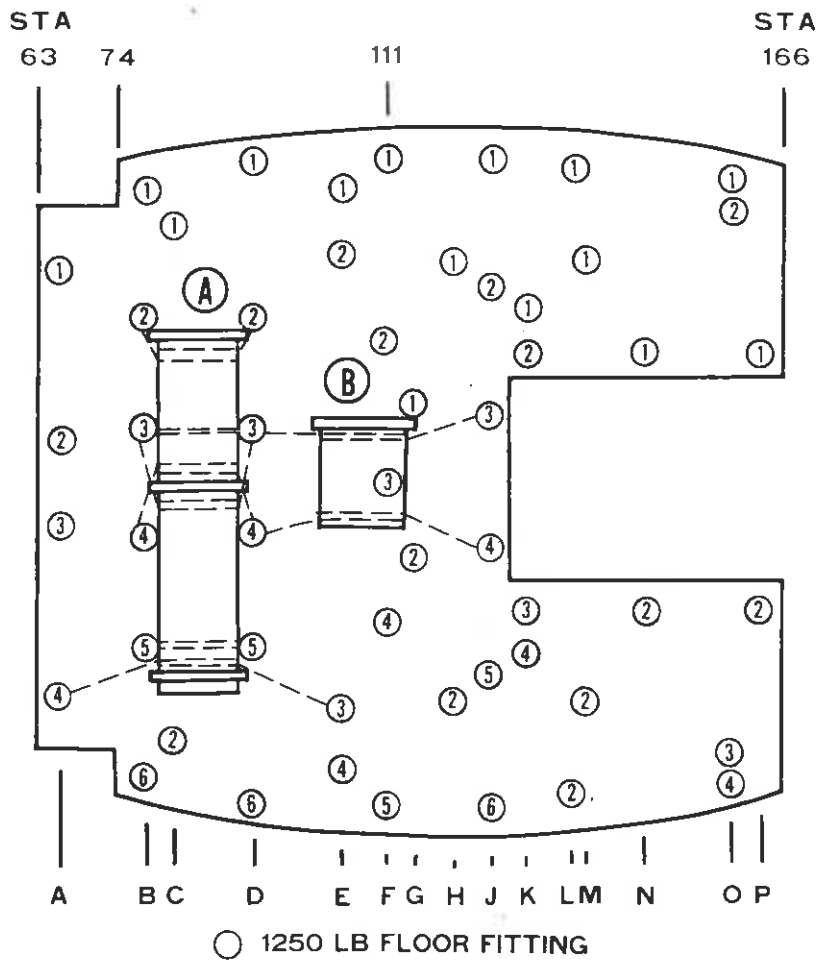

ITEM	DESCRIPTION OF ITEM	ITEM FACING	LOCATION OF REFERENCE POINT		LOCATION OF CG (STA)	APPROX WT (LB)
			REFERENCE POINT	STATION		
A	PROJECTILE, M422, IN PROJECTILE CASE, M500 [WITH PAL]	TOP RIGHT	FORWARD EDGE	80	86	300
		TOP RIGHT	FORWARD EDGE	80	86	330
B	ACCESSORY PARTS CASE [AN CAN]	TOP RIGHT	FORWARD EDGE	103	109	24

Figure 10. Tiedown diagram for 8-inch atomic projectile, M422, configuration II (assembled storage configuration), in UH-1D/H helicopters.

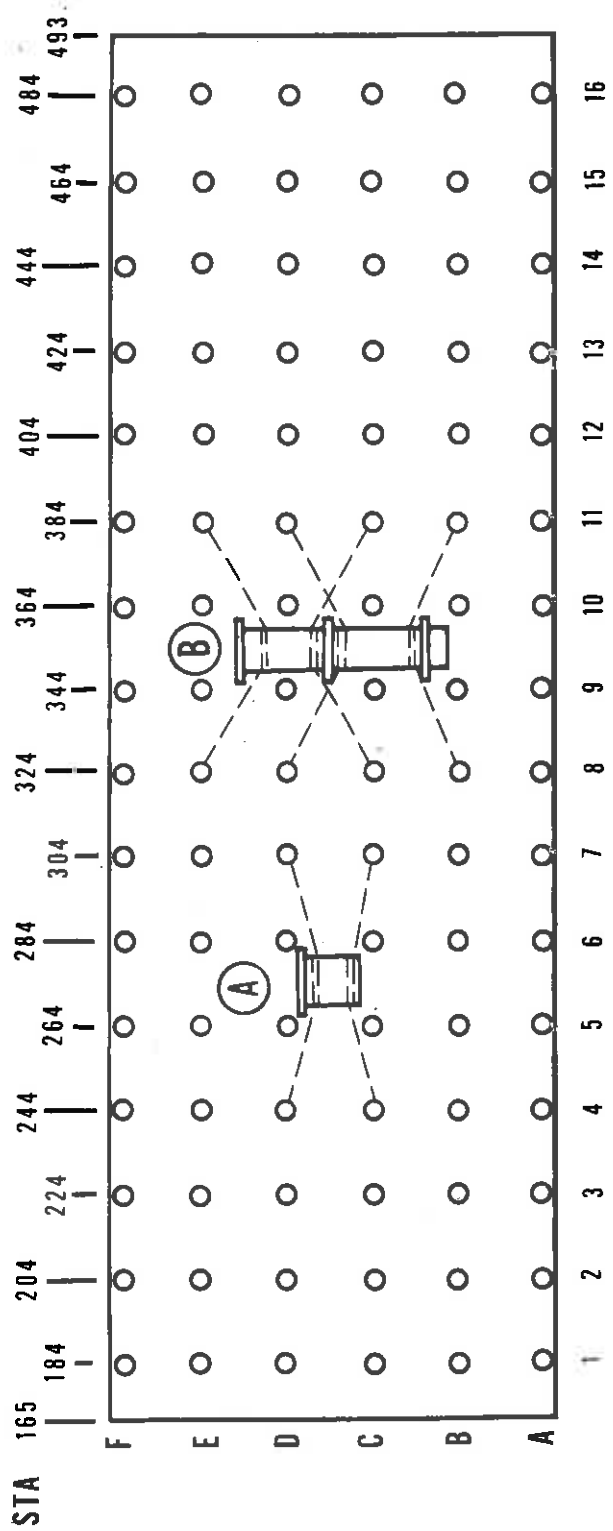

○ 5000 LB TIEDOWN FITTING

ITEM	DESCRIPTION OF ITEM	ITEM FACING	LOCATION OF REFERENCE POINT		LOCATION OF CG OF STA)	APPROX WT (LB)
			REFERENCE POINT	STATION		
(A)	ACCESSORY PARTS CASE (AN CAN)	TOP RIGHT	FORWARD EDGE	268	274	24
(B)	PROJECTILE, M422, IN PROJECTILE CASE, M500 (WITH PAL)	TOP RIGHT	FORWARD EDGE	348	354	300
		TOP RIGHT	FORWARD EDGE	348	354	330

Figure 11. Tiedown diagram for 8-inch atomic projectile, M422, configuration II (assembled storage configuration), in CH-54 helicopter universal military pod.

**Table 9. Tiedown Data for 8-Inch Atomic Projectile, M422, Configuration II
(Assembled Storage Configuration), in UH-1D/H Helicopters**

Item	Tiedown fitting		Tiedown device*		Attach to item
	designation	capacity in 1,000 lb	type	capacity in 1,000 lb	
A	B2/D2	1.25	CGU-1/B	5	One turn over and around the container.
	B3/D3	1.25	CGU-1/B	5	One turn over and around the container.
	B3/D3	1.25	CGU-1/B	5	One turn over and around the container below the center ring roll.
	B4/D4	1.25	CGU-1/B	5	One turn over and around the container above the center ring roll.
	B5/D5	1.25	CGU-1/B	5	One turn over and around the container.
B	A4/E3	1.25	CGU-1/B	5	One turn over and around the container.
	D3/J3	1.25	CGU-1/B	5	One turn over and around the container between the chime and upper ring roll.
	D4/J4	1.25	CGU-1/B	5	One turn over and around the container above the lower ring roll.

*MC-1 tiedown device may be used.

**Table 10. Tiedown Data for 8-Inch Atomic Projectile, M422, Configuration II
(Assembled Storage Configuration), in CH-54 Helicopter Universal Military Pod**

Item	Tiedown fitting		Tiedown device*		Attach to item
	designation	capacity in 1,000 lb	type	capacity in 1,000 lb	
A	C4/C7	5	CGU-1/B	5	One turn over and around the container above the lower ring roll.
	D4/D7	5	CGU-1/B	5	One turn over and around the container between the chime and upper ring roll.
B	B8/B11	5	CGU-1/B	5	One turn over and around the container.
	C8/C11	5	CGU-1/B	5	One turn over and around the container above the center ring roll.
	D8/D11	5	CGU-1/B	5	One turn over and around the container below the center ring roll.
	E8/E11	5	CGU-1/B	5	One turn over and around the container.

*MC-1 tiedown device may be used.

(3) *Unloading.* Four men can unload the two containers from any of the helicopters or the pod in approximately 10 minutes.

6. External Transport

WARNING

The contents of paragraph 6 are for information and training purposes only and are not to be construed as authority for external transport of the projectile by helicopter. Only dummy loads may be used for practice and/or training exercises. War reserve nuclear weapons shall not be moved by external transport except in emergency conditions (i.e. emergency evacuation from fire or flood) when the situation does not allow time to prepare and move the nuclear weapons by internal transport.

WARNING

Always assume that a charge of static electricity is present on the helicopter. Use of some type of discharge ap-

paratus (figure 4-1, TM 55-450-19) to ground the hook and discharge electricity is necessary to prevent shock when the hook is touched. After discharge of electricity, the hook is grasped quickly and firmly and held, if possible, until the hookup is completed. If contact with the hook is lost after initial grounding, the hook must be grounded again before it is touched. Do not use the load as a ground contact. After air delivery and before handling, again ground the load to discharge any accumulated/retained static electricity.

CAUTION

When performing external air transport by CH-54 helicopter, a large metal clevis will be used to attach the load to the cargo hook as a nylon sling ring will tend to adhere to the hook thereby preventing release of the load. However,

when performing similar transport by UH-1-series or CH-47 helicopter, a nylon sling ring will be used in lieu of a metal clevis to prevent damage to the cargo hook.

NOTE

Rigging figures for the 8-inch atomic projectile, M422, depict the carrying cases, M102, which will be replaced by containers, H1343. The containers, H1343, will be positioned at locations shown in the figures for the carrying cases, M102, and restrained as prescribed in paragraph 6b.

a. Transport of configuration I (stockpile storage configuration-four containers).

(1) *Materials.*

(a) One sling, cargo net, metallic, octagonal, 5,000-pound-capacity (NSN 3940-00-774-8507).

(b) Three 15-foot cargo tiedown straps (NSN 1670-00-360-0540).

(c) Three load binders (NSN 3990-00-360-0248).

(d) Three quick-fit cargo tiedown strap fasteners (NSN 1670-00-360-0340).

(e) Cord, nylon, natural, type-III, 550-pound-capacity (NSN 4020-00-240-2146), or equivalent.

(f) Two inch pressure-sensitive tape (NSN 7510-00-663-0196), or equivalent.

(g) One piece of 48- by 40- by $\frac{3}{4}$ -inch plywood.

(h) Energy-dissipating honeycomb (NSN 1670-00-753-3928), as follows:

1. One piece, 48- by 16- by 3-inch.
2. One piece, 25- by 10- by 3-inch.
3. Four pieces, 15- by 10- by 3-inch.
4. Two pieces, 25- by 16- by 3-inch.

(i) Additional materials used with CH-47 helicopter only:

1. One 8-foot, two-loop, air delivery cargo sling (NSN 1670-00-753-3789) (has rated capacity of 6,500 pounds).

2. One 3-foot, three-loop, air delivery cargo sling ring (NSN 1670-00-753-3788) (has rated capacity of 10,000 pounds).

(2) *Preparation and rigging.*

(a) Spread net and place plywood in center of net with tiedown straps positioned under plywood (fig 12). Four men can prepare the containers and rig the cargo net (including ringer when required) for external transport in approximately 15 minutes.

(b) Position containers A, B, C, and D on plywood as shown in figure 12. Component D has

its longitudinal axis parallel to the longest dimension of the plywood.

(c) Insert honeycomb pieces between containers as shown in figure 13: one 48- by 16- by 3-inch piece between containers A, C, and D; one 25- by 16- by 3-inch piece between B and A, and a similar piece between B and C; two 15- by 10- by 3-inch pieces between B and D and two similar pieces on the opposite side of B; and one 25- by 10- by 3-inch piece on top of B between A and C, as shown in figure 14.

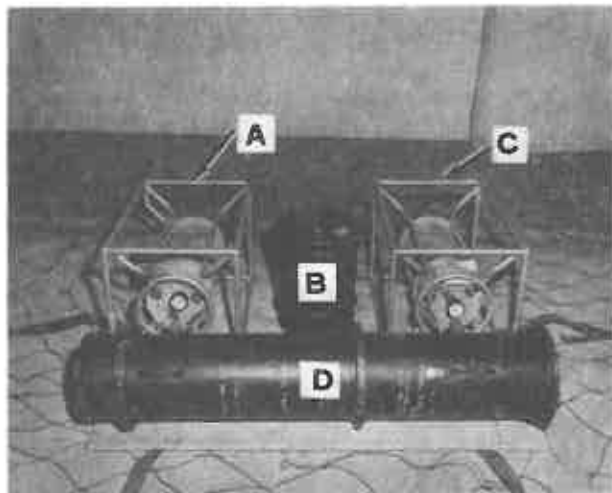

Figure 12. Containers for 8-inch atomic projectile, M422, configuration I (stockpile storage configuration).

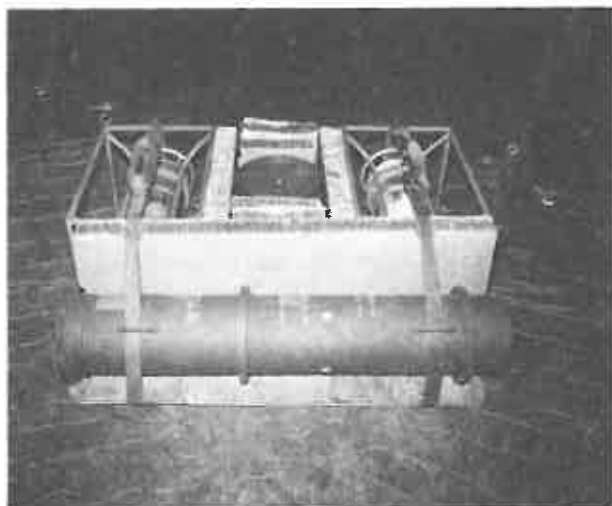

Figure 13. Containers for 8-inch atomic projectile, M422, configuration I (stockpile storage configuration), with honeycomb inserted. Note that straps pass through fittings on projectile case, M500.

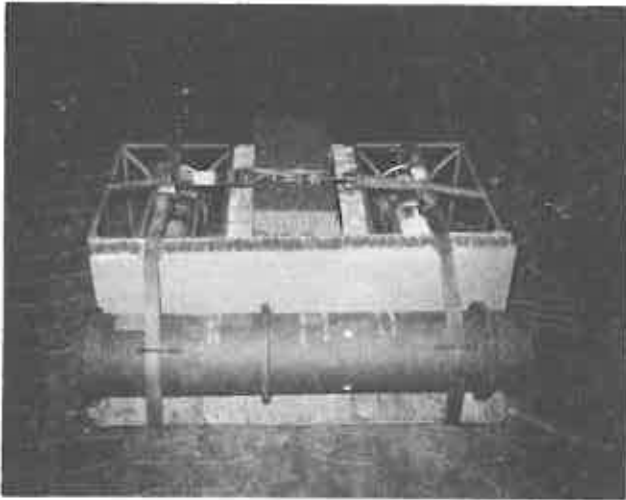

Figure 14. Containers for 8-inch atomic projectile, M422, configuration I (stockpile storage Configuration), secured with tiedown straps. Note position of honeycomb covering accessory parts case.

(d) Restrain the containers using three strap assemblies. Each strap assembly consists of one 15-foot cargo tiedown strap, one quick-fit strap fastener, and one load binder. Pass a strap assembly over container C and through strap fitting of container D (fig 14). Tighten securely with load binder. Fold the running end of the strap assembly, and safety tape to the load binder. Fasten a second strap assembly similarly over containers A and D.

(e) Pass a third strap assembly over containers A, B, and C (fig. 14); tighten securely with the load binder. Fold the running end of the strap assembly, and safety tape to the load binder.

(f) Attach net draw cables to the 6-inch ring forming the apex that is attached to the helicopter hook; this should be done so that four ring-end snap fasteners converge at the base of the 6-inch ring and three free-end snap fasteners are attached to the 2 $\frac{3}{8}$ -inch rings (fig 15).

(g) Draw the net up evenly and smoothly around the load; cluster the draw cables by hand, and tie or tape the net above the load (fig 16 and 17).

(h) In addition to the foregoing, the following procedure is applicable when the load is transported by CH-47 helicopter: choker hitch one end of the 8-foot cargo sling (functions as vertical riser) to the 6-inch ring on the cargo net; then pass the 3-foot sling ring through the upper loop of the 8-foot sling. Connect free ends of the 3-foot sling with the link assembly, and safety-tie the assembly to prevent accidental release. The 3-foot sling forms the apex for at-

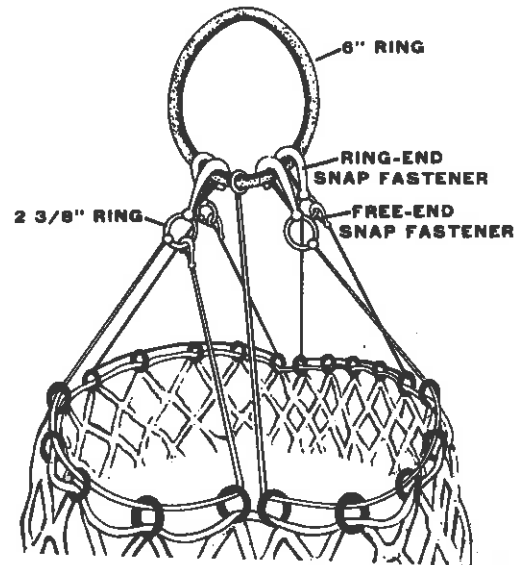

Figure 15. Attachment of draw cable snap fasteners to 6-inch ring (top) and to 2 $\frac{3}{8}$ -inch rings.

tachment to the helicopter cargo hook. The vertical riser dampens vibration tendencies.

(3) *Derigging.* Four men can derig the cargo net (including riser when used) in approximately 5 minutes. The space interval separating the carrying cases must be no less than the minimum distance prescribed by TM 39-20-7.

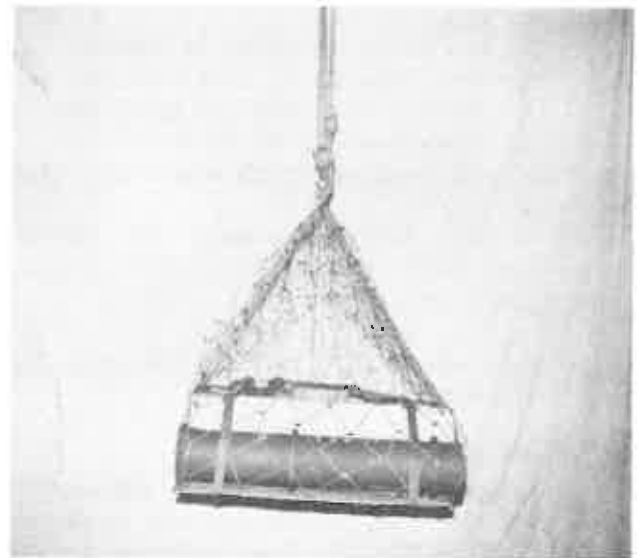

Figure 16. Containers for 8-inch atomic projectile, M422, configuration I (stockpile storage configuration), in cargo net prepared for external transport. Note that net is tied above load.

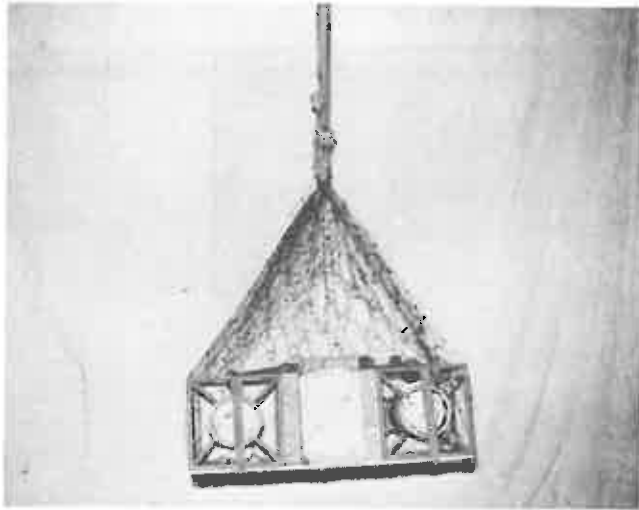

Figure 17. Containers for 8-inch atomic projectile, M422, configuration I (stockpile storage configuration), in cargo net prepared for external transport. Note position of tiedown straps around carrying cases, M102.

b. Transport of two containers, H1343, configuration I (stockpile storage configuration).

WARNING

The container, H1343, must stand on base for storage and shipment. Port-hole on top of container is not to be covered, except that it may be covered by tiedowns during transport.

(1) *Materials.* Same as prescribed in a(1)(a).

(2) *Preparation and rigging.*

(a) Position containers, H1343, on plywood at locations shown in figure 12 for the carrying cases, M102.

(b) Observe guidance in a(2)(a) and a(2)(c) through (e).

(c) Restrain each container by passing a strap assembly around the handle, over the top, and around the opposite handle. Pass the third strap assembly (perpendicular to the first two straps) around the handles of each container and over the tops of both containers.

(d) Observe guidance in a(2)(f) through (h).

(3) *Derigging.* Observe guidance in a(3).

c. Transport of configuration II (assembled storage configuration: two containers).

WARNING

When in the assembled storage configuration, the projectile, M422, in projectile case, M500, must be separated a minimum of 3 feet (0.9 meter) (center-to-center spacing) from any other nuclear weapon or nuclear component.

(1) *Materials.*

(a) One sling, cargo net, metallic, octagonal, 5,000-pound-capacity (NSN 3940-00-8507).

(b) Three 15-foot cargo tiedown straps (NSN 1670-00-360-0540).

(c) Three load binders (NSN 3990-00-360-0248).

(d) Three quick-fit cargo tiedown strap fasteners (NSN 1670-00-360-0340).

(e) Cord, nylon, natural, type-III, 550-pound-capacity (NSN 4020-00-240-2146), or equivalent.

(f) Two-inch pressure-sensitive tape (NSN 7510-00-663-0196, or equivalent).

(g) One piece of 48- by 40- by 3/4-inch plywood.

(h) One piece of energy-dissipating honeycomb (NSN 1670-00-753-3928), 18- by 10- by 3-inch.

(i) Wadding or suitable substitute.

(j) Additional materials used with CH-47 helicopter only:

1. One 8-foot, two-loop, air delivery cargo sling (NSN 1670-00-753-3789) (has rated capacity of 6,500 pounds).

2. One 3-foot, three-loop, air delivery cargo sling ring (NSN 1670-00-753-3788) (has rated capacity of 10,000 pounds).

(2) *Preparation and rigging.*

(a) Spread net and place plywood in center of net with tiedown straps positioned under plywood (fig 18). Four men can prepare the containers and rig the cargo net (including riser when required) for external transport in approximately 10 minutes.

(b) Position containers B and D on plywood as shown in figure 18. Component D has its longitudinal axis parallel to the longest dimension of the plywood.

(c) Insert honeycomb between containers B and D (fig 18).

(d) Restrain the containers using three strap assemblies. Each strap assembly consists of one 15-foot cargo tiedown strap, one quick-fit strap fastener, and one load binder. Pass a strap assembly around containers B and D (fig 18), and tighten securely with load binder. Fold the running end of the strap assembly, and safety tape to the load binder.

(e) Pass a second strap assembly around plywood and over containers B and D (fig 19), and tighten securely with load binder. Fold and tape the running end of the strap assembly. Tape the load binder to prevent accidental release.



Figure 18. Containers for 8-inch atomic projectile, M422, configuration II (assembled storage configuration). Note position of honeycomb and wadding.

(f) Pass a third strap assembly around plywood and over container D (fig 19 and 20), and tighten securely with load binder. Fold and tape the running end of the strap assembly (fig 19 and 20). Tape the load binder to prevent accidental release.

(g) Attach net draw cables to the 6-inch ring forming the apex which is attached to the helicopter hook; this should be done so that four ring-end snap fasteners converge at the base of the 6-inch ring and three free-end snap fasteners are attached to the 2 $\frac{3}{8}$ -inch rings (fig 15).

(h) Draw the net up evenly and smoothly around the load; cluster the draw cables by hand, and tie or tape the net above the load (fig 21).

(i) In addition to the foregoing, the following procedure is applicable when the load is transported by CH-47 helicopter: choker hitch one end of the 8-foot cargo sling (functions as vertical riser) to the 6-inch ring on the cargo net; then pass the 3-foot sling ring through the



Figure 19. Containers for 8-inch atomic projectile, M422, configuration II (assembled storage configuration), secured to plywood.



Figure 20. Containers for 8-inch atomic projectile, M422, configuration II (assembled storage configuration), secured to plywood. Note that running ends of straps are folded and taped.



Figure 21. Containers for 8-inch atomic projectile, M422, configuration II (assembled storage configuration), in cargo net prepared for external transport. Note use of nylon cord around the net.

upper loop of the 8-foot sling. Connect free ends of the 3-foot sling with the link assembly, and safety-tie the assembly to prevent accidental release. The 3-foot sling forms the apex for attachment to the helicopter cargo hook. The vertical riser dampens vibration tendencies.

(3) *Derigging.* Four men can derig the cargo net (including riser when used) in approximately 5 minutes. Insure that the projectile, M422, in projectile case, M500, is separated by a minimum distance of 3 feet (0.9 meter) (center-to-center spacing) from any other nuclear weapon or nuclear component.

APPENDIX A

REFERENCES

1. Army Regulations (AR)

10-16	US Army Nuclear and Chemical Surety Group
40-14	Control and Recording Procedures: Occupational Exposure to Ionizing Radiation
50-5	Nuclear Weapons and Materiel: Nuclear Surety.
(C) 50-103	Safety Rules for the Operation of the 8-Inch Howitzer Nuclear Weapon System (U).
55-203	Movement of Nuclear Weapons, Nuclear Components, and Related Classified Nonnuclear Materiel
95-27	Operational Procedures for Aircraft Carrying Dangerous Materials as Cargo
360-5	Army Information: Public Information Policies.
385-40	Accident Reporting and Records
(FOUO) 700-65	Nuclear Weapons and Nuclear Weapons Materiel
740-1	Storage and Supply Activity Operations

2. Field Manuals (FM)

1-100	Army Aviation Utilization
-------	---------------------------

3. Technical Bulletins (TB)

(SRD) 9-380-1	Security Classification of Nuclear Items (U)
385-2	Nuclear Weapons Firefighting Procedures

4. Technical Manuals (TM)

5-315	Fire Fighting and Rescue Procedures in Theaters of Operations
9-1100-218-10	Operator's Manual: M422 Atomic Projectile
(CRD)9-1100-218-20	Organizational Maintenance: M422 Atomic Projectile, M423 Training Atomic Projectile (U).
9-1300-206	Ammunition and Explosives Standards
38-250	Packaging and Handling of Dangerous Materials for Transportation by Military Aircraft
(CRD)39-0-1A	Numerical Index to Joint Atomic Weapons Publications (including Related Publications) (Army Supplement) (U)
(SRD)39-20-7	Nuclear Safety Criteria (U)
(CRD)39-20-11	General Firefighting Guidance for Nuclear Weapons (U)
39-45-51	Transportation of Nuclear Weapons Materiel
(SRD)39-45-51A	Transportation of Nuclear Weapons Materiel (Supplement) Shipping and Identification Data for Stockpile Major Assemblies (U)
39-45-51C	Transportation of Nuclear Weapons Materiel (Supplement): DOD Criteria, Courier Responsibilities, Military Shipment, and Vehicle Loading/Tiedown Procedures
(CRD)39-50-8	Emergency Destruction of Nuclear Weapons (U)
55-450-8	Air Transport of Supplies and Equipment: External-Transport Procedures
55-450-11	Air Transport of Supplies and Equipment: Helicopter External Loads Rugged With Air Delivery Equipment

55-450-15	Air Movement of Troops and Equipment (Nontactical)
55-450-18	Air Transport of Supplies and Equipment: Internal and External Loads, CH-47 Helicopter
55-450-19	Air Transport of Supplies and Equipment: Helicopter External Lift Rigging Materiel, Techniques and Procedures
55-1520-209-10	Operator's Manual: Army Model, CH-47A Helicopter
55-1520-210-10	Operator's Manual: Army Model, UH-1D/H Helicopter
55-1520-217-10-1	Operator's Manual: Army Model CH-54A Helicopters
55-1520-217-10-2	Operator's Manual: Army Model CH-54B Helicopters
55-1520-219-10	Operator's Manual: Army Model UH-1B Helicopter
55-1520-220-10	Operator's Manual: Army Model UH-1C/M Helicopter
55-1520-227-10	Operator's Manual: Army Model CH-47B and CH-47C Helicopters
55-1100-218-12-6	Air Transport Procedures: 8-Inch Atomic Projectile, M422, in U-6A Aircraft.
55-1100-218-12-8	Air Transportability Guidance: External Transport of 8-Inch Atomic Projectile, M422, by U-6A Aircraft.

APPENDIX B

CONVERSION TABLES

1. Common Metric Abbreviations

m = meter
dm = decimeter
cm = centimeter
mm = millimeter

kg = kilogram
km = kilometer
t = metric ton

2. Linear Measure

1 mi = 1,609.35 m
1 yd = 0.9144 m
1 ft = 0.3048 m
1 in = 0.0254 m
1 m = 10 dm = 100 cm = 1000 mm

1 km = 0.6214 mi
1 m = 1.0936 yd
1 m = 3.2808 ft
1 m = 39.37 in

3. Surface Measure

1 sq yd = 0.8361 sq m
1 sq ft = 0.0929 sq m
1 sq in = 0.00065 sq m

1 sq m = 1.196 sq yd
1 sq m = 10.764 sq ft
1 sq m = 1,500 sq in

4. Cubic Measure

1 MTON = 1.1328 cu m
1 cu yd = 0.76455 cu m
1 cu ft = 0.02832 cu m
1 cu in = 0.000016 cu m

1 cu m = 0.883 MTON
1 cu m = 1.31 cu yd
1 cu m = 35.31 cu ft
1 cu m = 61,023 cu in

5. Weight

1 LTON = 1,016.05 kg
1 t = 1,000 kg
1 STON = 907.18 kg

1 lb = 0.45359 kg
1 t = 2,204.63 lb
1 kg = 2.2046 lb

6.

The following simplified conversion factors are accurate to within 2 percent for quick computations:

- a. *Inches to Centimeters*—Multiply inches by 10 and divide by 4.
- b. *Yards to Meters*—Multiply yards by 9 and divide by 10.
- c. *Miles to Kilometers*—Multiply miles by 8 and divide by 5.
- d. *Pounds to Kilograms*—Multiply pounds by 5 and divide by 11.

Paragraph 7-37, FM 55-15 and paragraph 2-15, TM 55-450-15 contain additional detailed conversion factors.

7.

The following conversions are provided for guidance when procuring lumber, wire rope, or wire in areas that use the metric system. Lumber sizes are rounded off to nearest ½ cm.

a. *Lumber.*

2-in. × 4-in. × desired length = 5-cm × 10-cm × desired length
1-in. × 6-in. × desired length = 2.5-cm × 15-cm × desired length
6-in. × 8-in. × desired length = 15-cm × 20-cm × desired length

1-in. × 12-in. × desired length = 2.5-cm × 30-cm × desired length
(length normally expressed in ft or m).

b. Wire rope.

5/8-in. diam = 9.5-mm diam
1/2-in. diam = 12.7-mm diam
3/8-in. diam = 15.8-mm diam
3/4-in. diam = 19.0-mm diam
7/8-in. diam = 22.2-mm diam
1-in. diam = 25.4-mm diam
1 1/4-in. diam = 31.7-mm diam
1 1/2-in. diam = 38.1-mm diam

Round off to next higher whole mm of available wire rope sizes.

*c. Wire. No. 8 gauge annealed (11/64-in. diam) = 4.37-mm diam. Round off as in *b* above.*

8. Remarks

It should be noted that standard abbreviations used on drawings, specifications, and technical documents, in some instances, are not in agreement with AR 310-50. Such abbreviations are governed by MIL-STD 12.

By Order of the Secretary of the Army:

Official:

PAUL T. SMITH
Major General, United States Army
The Adjutant General

FRED C. WEYAND
General, United States Army
Chief of Staff

Distribution:

Active Army, ARNG, USAR: To be distributed in accordance with DA Form 12-31, Section 1 Operator requirements for CH-47B/C, CH-54A; CH-54B; UH-1B, UH-1C/M, UH-1D/H (Qty rqr block no 161, 171, 181, 241, 251, 261); DA Form 12-34B, requirements for Air Transport Procedures; Nuclear Warheads and Projectiles (Qty rqr block no. 155) and DA Form 12-35, Section 111 requirements for Projectile M422 (Qty rqr block no. 59).