



FM 6-11

**THE
PERSHING II
FIRING BATTERY
(FINAL DRAFT)**

DISTRIBUTION RESTRICTION - This publication contains technical or operational information that is for official Government use only. Distribution is limited to US Government agencies. Requests for outside the US Government for release of this publication under the Freedom of Information Act or the Foreign Military Sales Program must be made to Commandant, US Army Field Artillery School, ATTN: ATSF-W, Fort Sill, OK 73503.

OCTOBER 1984

APPENDIX C	DEFENSE DIAGRAM
APPENDIX D	NUCLEAR, BIOLOGICAL, CHEMICAL DEFENSE
APPENDIX E	TRAINING FOR A FIELD ENVIRONMENT
APPENDIX F	ESSENTIAL ELEMENTS OF FRIENDLY INFORMATION
APPENDIX G	INTERNATIONAL STANDARDIZATION AGREEMENTS
INDEX	
ACRONYMS	

PREFACE

Pershing II is a theater fire support missile system that is terminally guided and capable of accurately delivering tactical nuclear warheads. It is the US Army's longest range weapon system and has the greatest payload. The system is ground mobile, air transportable, and can be employed worldwide.

This publication describes doctrine, techniques, considerations, and planning factors to maintain combat readiness and sustain combat operations within the Pershing II firing battery. Guidance is provided on the duties of key personnel and training of sections, platoons, and the battery as a whole.

All users of this publication are encouraged to make recommendations for changes and improvements. Comments should be keyed to the specific page, paragraph, and line of the text in which the change is recommended. Rationale should be provided in support of comments to ensure complete understanding and evaluation. Comments should be prepared, using DA Form 2028 (Recommended Change to Publications), and forwarded to Commandant, US Army Field Artillery School, ATTN: ATSF-WGP, Fort Sill, Oklahoma 73503.

FM 6-11 is designed for use in conjunction with user's manuals for the appropriate equipment and with other technical manuals as referenced throughout this manual (appendix A).

When used in this publication, "he," "him," and "men" represent both the masculine and feminine genders unless otherwise stated.

CHAPTER 1 SYSTEM DESCRIPTION

Pershing II (PII) is a ground-mobile, surface-to-surface, nuclear weapon system. It is a solid-propellant missile with ground support equipment (GSE) mounted on wheeled vehicles. The missile may be launched quickly and is an effective weapon against a broad spectrum of targets.

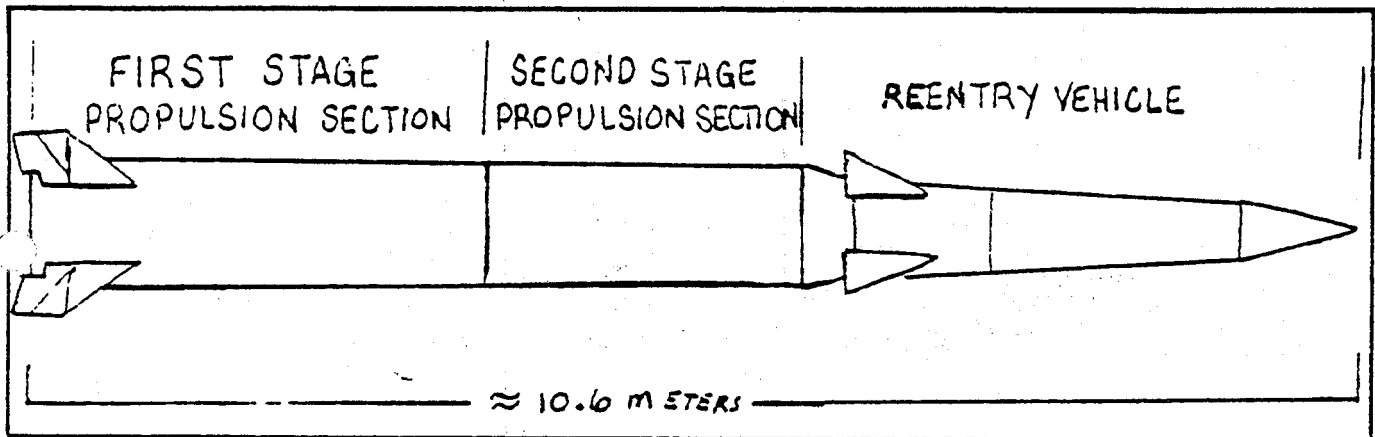

Figure 1-1. Pershing II missile.

1-1. MISSILE CHARACTERISTICS

The Pershing II missile, with the normal configuration of first and second stage propulsion sections and the reentry vehicle (fig 1-1), weighs more than 16,000 pounds, is about 10.6 meters long, and has a range of 1,000 miles (1800 km). A kit is available with which the erector launcher can be converted to adapt to a single stage missile, if required. The result is a missile with reduced weight, length, and range.

a. First Stage Propulsion Section. The first stage provides the initial thrust required to propel the missile toward a ballistic trajectory. It consists of a rocket motor with attached forward and aft skirts (fig 1-2). The forward skirt allows the second stage to be mated to the first stage. In a single stage configuration, the reentry vehicle would be mated directly to the forward skirt. The forward skirt contains three thrust termination ports, which will stop the forward thrust at the time determined by the guidance and control section of the reentry vehicle when the missile is fired in the single stage configuration. The first stage contains a motor ignition safe/arm mechanism designed to prevent the accidental launching of the missile. The aft skirt contains four air vanes (two fixed and two movable) and a swivel nozzle, which provide pitch and yaw control. The motor cases of both

the first and second stages are made of Kevlar, a strong, lightweight material.

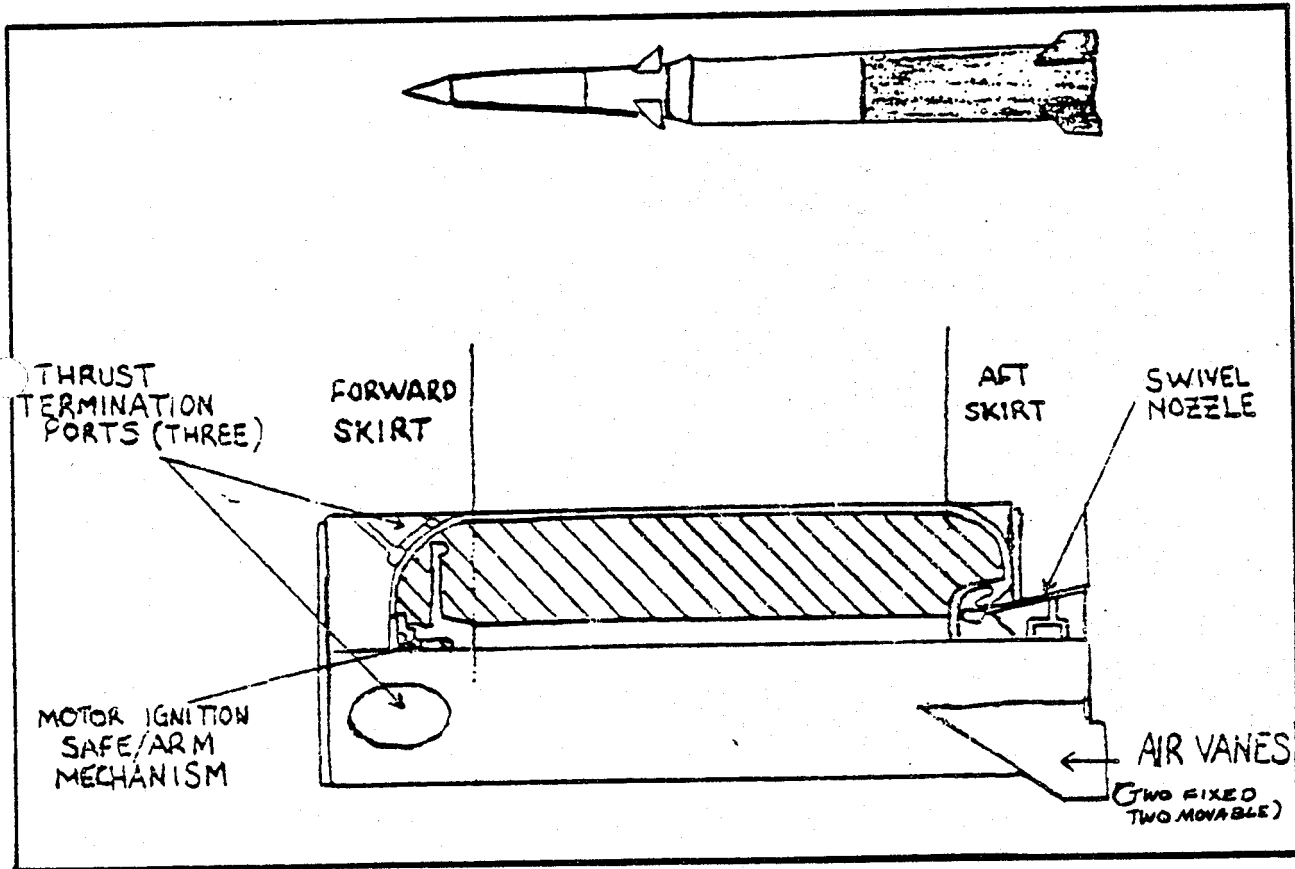

Figure 1-2. First stage propulsion section.

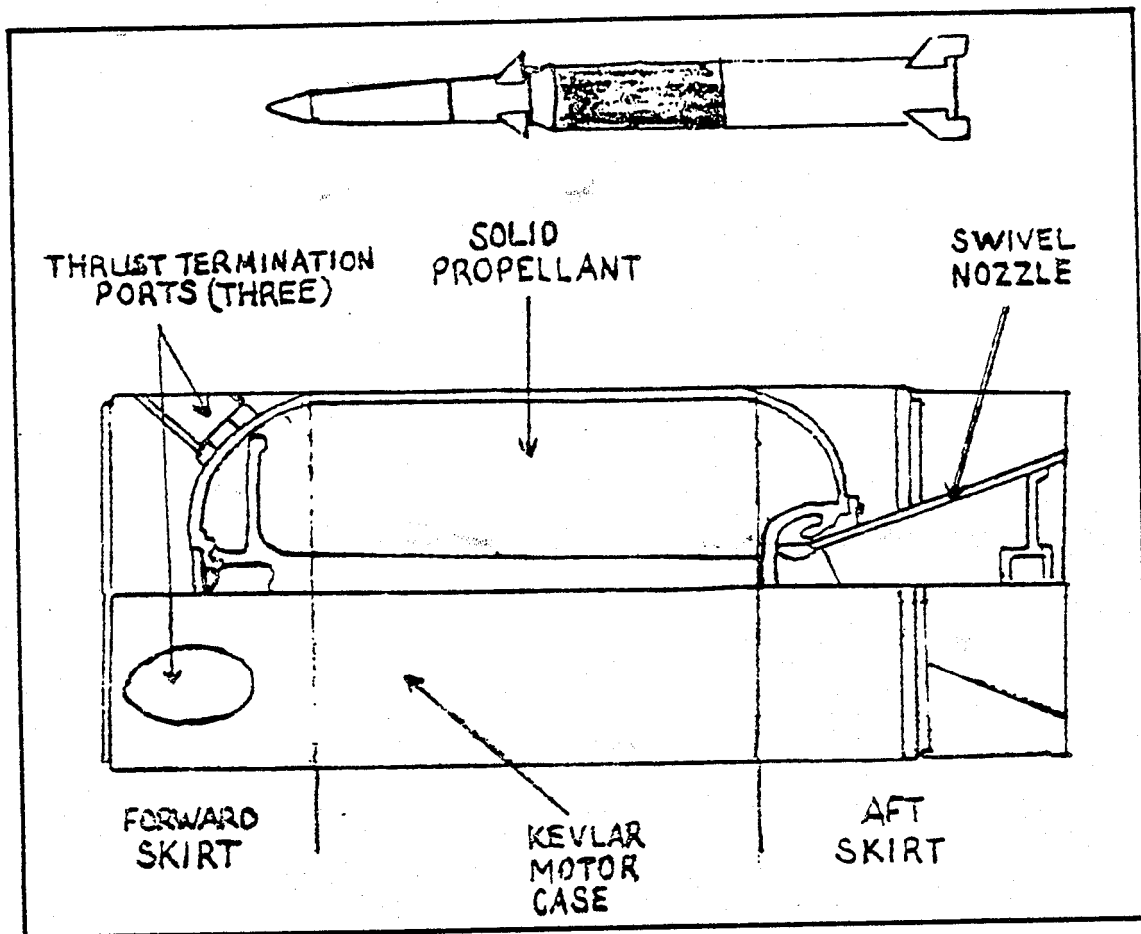

Figure 1-3. Second stage propulsion section.

b. Second Stage Propulsion Section. The second stage produces thrust for a variable amount of time and accelerates the missile to the required programmed velocity for achieving target range. Like the first stage, the second stage consists of a solid-propellant rocket motor with attached forward and aft skirts (fig 1-3). The forward skirt contains three thrust termination ports, which will stop the forward thrust at the time determined by the guidance and control section of the reentry vehicle. The forward skirt also allows the stage to be mated to the reentry vehicle. The aft skirt houses a swivel nozzle with two hydraulic actuators for nozzle control. It provides a means for mating the first and second stages. The aft skirt also contains a linear shaped charge to cause first stage separation.

c. Reentry Vehicle. The reentry vehicle (RV) consists of three sections: a guidance and control/adaptor (G&C/A) section, a warhead section, and a radar section (fig 1-4).

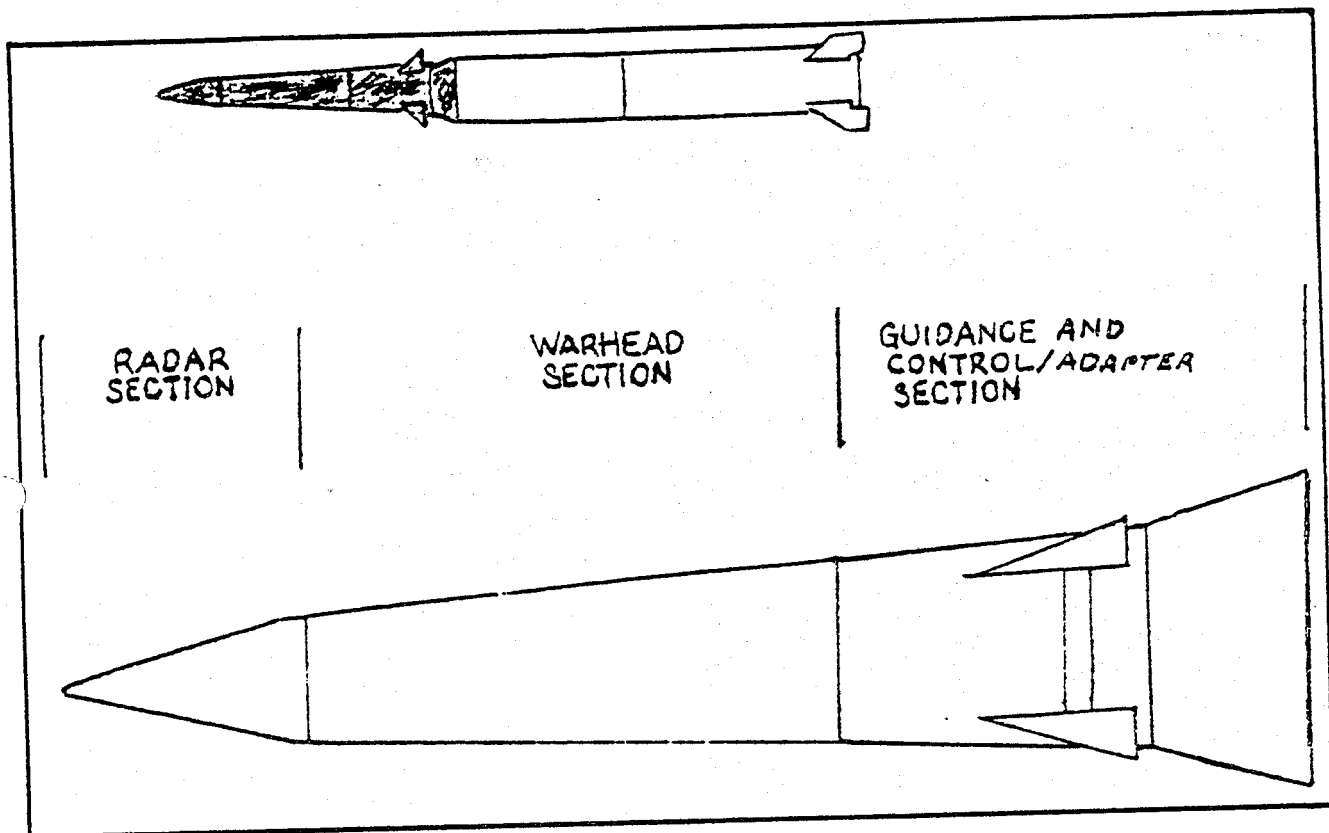

Figure 1-4. Reentry vehicle.

(1) The G&C/A section contains--

- (a) The terminal guidance system.
- (b) Thrusters to provide attitude control while in less dense atmosphere.
- (c) Air vanes for roll control during second stage thrust and full control once the RV returns to denser atmosphere.

The adapter portion is designed so the reentry vehicle can be mated to either the first or second stage propulsion section (fig 1-5). The adapter remains attached to the propulsion section when the reentry vehicle separates from it.

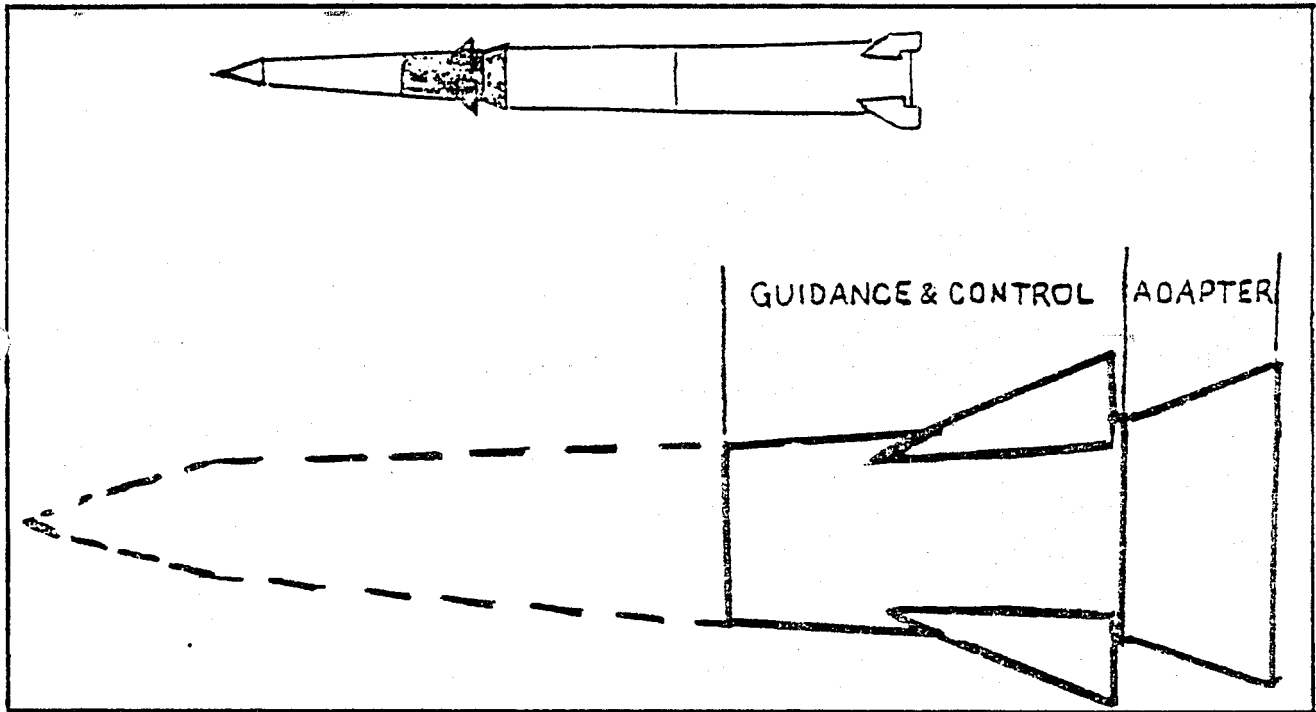

Figure 1-5. Guidance and control/adapter section.

(2) The warhead section is a conical aluminum structure coated with an ablative material. It houses a nuclear warhead that provides an air burst, surface burst, or air/surface burst option capability as well as a Permissive Action Link (PAL) unlocking device (fig 1-6). Also housed in the warhead section is the rate gyro, which sends trajectory information to the G&C/A section.

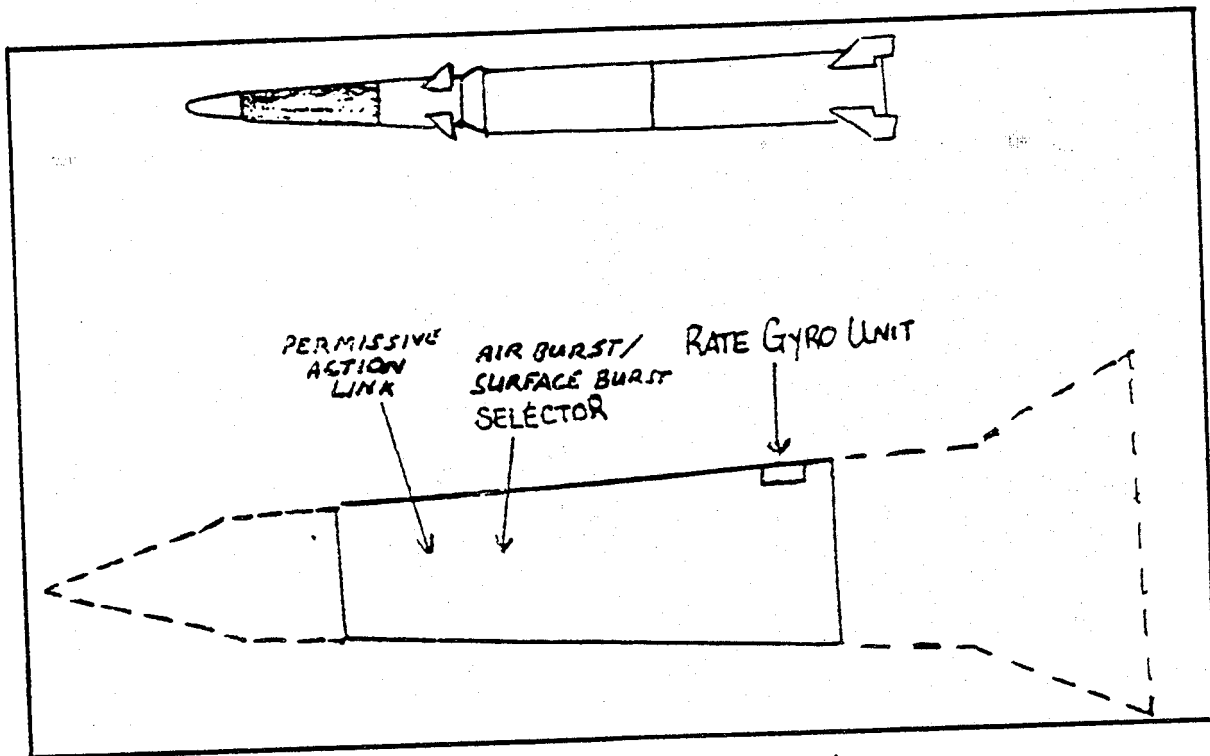

Figure 1-6. Warhead section.

(3) The radar section, consisting of a radome assembly, a radar unit, and a stabilized antenna unit, is located in the nose of the reentry vehicle (fig 1-7). It transmits radio frequency (RF) energy to the target area, receives altitude and video return, and sends this altitude information to the on-board computer in the G&C/A section.

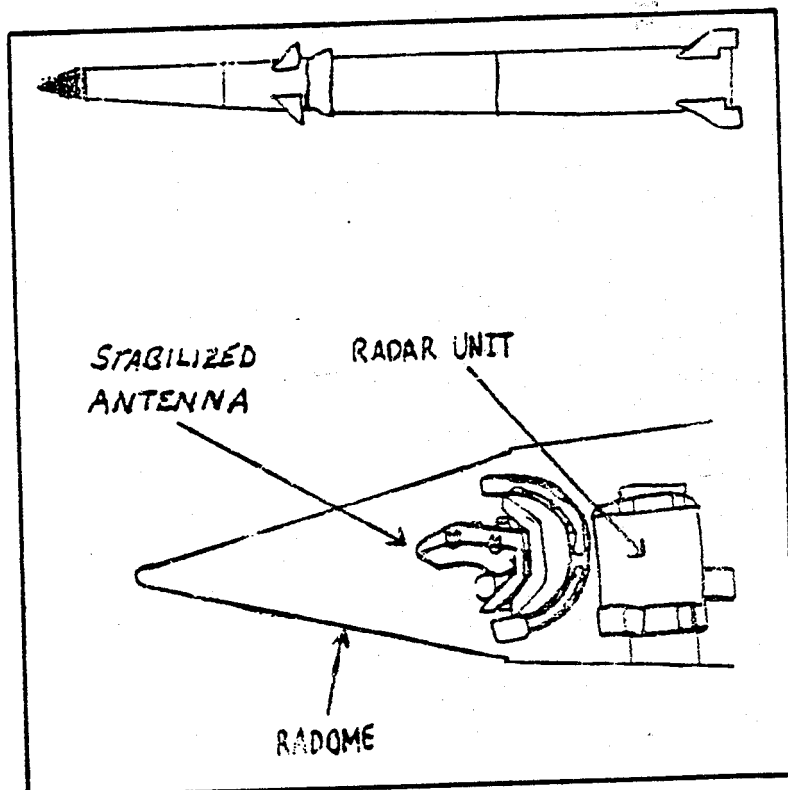

Figure 1-7. Radar section.

1-2. GROUND SUPPORT EQUIPMENT

To be effectively employed, the Pershing missile requires certain system-peculiar ground support equipment (GSE) (fig 1-8). This GSE is designed to provide speed, flexibility, reliability, and improved survivability.

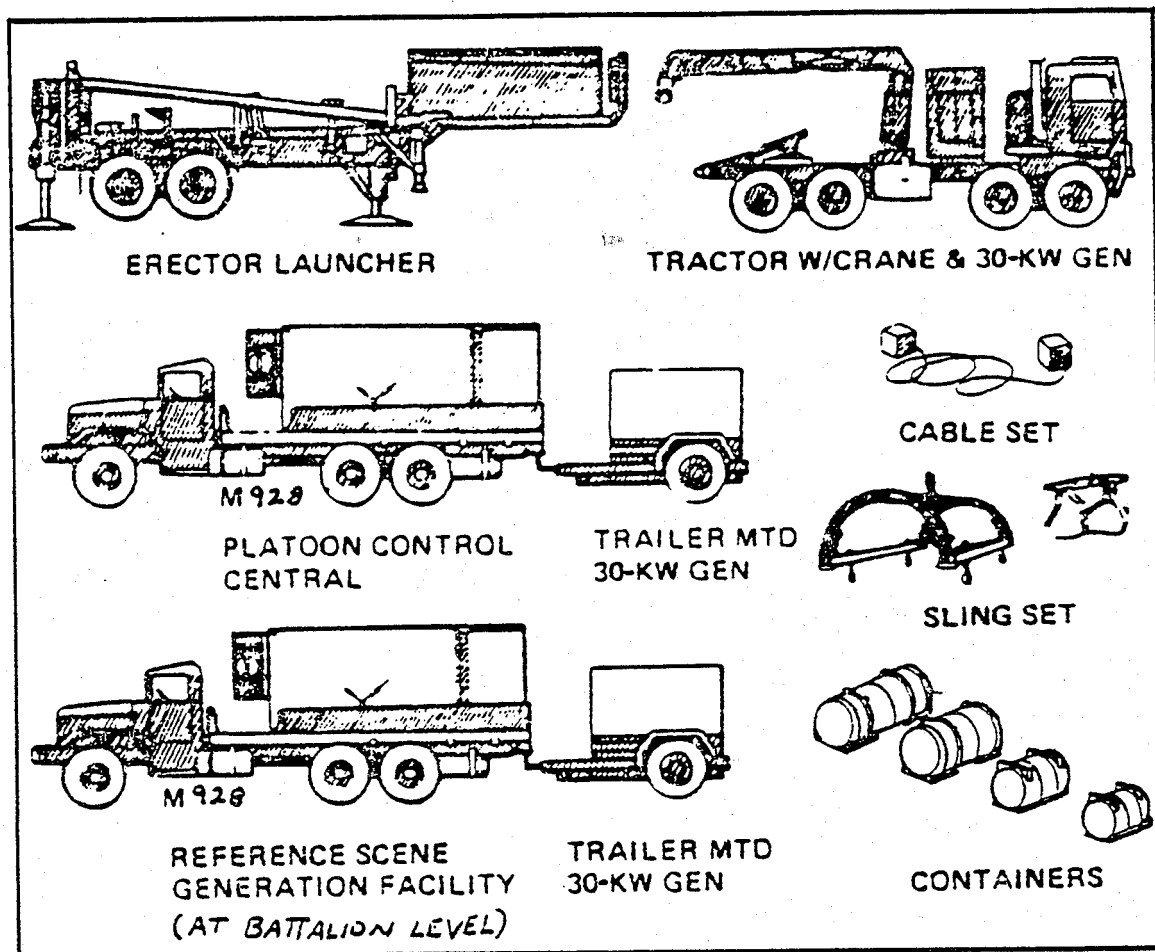

Figure 1-8. Ground support equipment.

a. Erector launcher and prime mover.

(1) Each missile is fired from an erector launcher (EL). The EL consists of a transporter frame assembly that supports an erection system, a leveling system, a radar section/warhead section assembly and transport pallet, a reentry vehicle cooling system, a ground integrated electronic unit (GIEU), a hydraulic control panel and two 28-volt DC power supplies. Through the GIEU, the EL operator can test and monitor EL functions and, when required, can control the countdown. The GIEU also provides launch site communications between the erector launcher and the platoon control central (PCC).

(2) The prime mover for the erector launcher is a 10 ton tractor with a self-recovery winch. Mounted on this tractor is the 30-kw generator, a power distribution box, a crane with a telescopic extension, and hydraulic stabilizer jacks.

b. Platoon Control Central.

(1) Each firing platoon has a platoon control central (PCC) which is mounted on a 5-ton, long-wheelbase, cargo truck. The power source for the PCC is the trailer-mounted 30-kw generator. The PCC serves as the platoon command post, communications center, and launch control facility. Three remote launch control units (RLCU) are located in the PCC to provide PAL functions, safe/arm functions and firing control for up to three missiles on launchers. Adjacent to the RLCUs is an interface logic assembly (ILA) console containing three keyboards for manual data entries, three alphanumeric displays for detailed countdown status information, and three lineprinters that provide hard copies of countdown data.

(2) The PCC also contains a launch window status display panel and a missile status display panel. The launch window status display panel computes time limits within which the platoon may launch its missiles. The missile status display panel provides the officer in charge (OIC) current missile countdown status information as it is developed by the ILA console.

c. Reference Scene Generation Facility. There are two reference scene generation facilities (RSGF) per Pershing II battalion. The RSGF consists of equipment used to generate target cartridges. It uses a digital data base provided by the Defense Mapping Agency (DMA) to produce magnetic tape cartridges of digital target scenes for entry into the missile through the GIEU. The RSGF is mounted on a 5-ton, long-wheelbase truck. It contains a computer, mass storage units, video displays, and tape cassette unit. The power source for the RSGF is a trailer-mounted 30 kw generator.

d. Cable Sets. Data and power distribution within a platoon area is accomplished through a ground support cable network.

(1) There are two primary cables connected to the erector launcher that are required to launch the missile.

(a) A 50-foot cable provides power from the 30-kw generator set to the erector launcher through a power distribution box housed on the prime mover.

(b) A 400-foot cable conducts all electronic signals between the PCC and the erector launcher.

(2) Additional cables include the following:

(a) A 7-foot cable connecting the 30-kw generator set with the power distribution box.

(b) A 150-foot AC power cable connecting a commercial or an alternate standby power source to the power distribution box. This cable connects power distribution boxes for distribution of standby power.

(c) 50-foot ground cables with associated stakes, clamps, and rods.

(d) Two short cables from the GIEU to the first, stage which provide power and electrical signals between the EL and the missile.

e. Containers. Containers are used to transport or store missile sections that are not assembled on an erector launcher.

(1) All containers are top loading. The container covers are lifted by two top mounted hoisting eyes.

(2) All missile section containers are designed to allow the performance of in-container tests, through access ports, without removal of the container covers.

f. Sling Sets. The sling sets used in the PII firing battery consist of two- and four-leg slings, propulsion section hoisting beams, and a universal sling.

(1) The two-leg sling is provided for removal and replacement of all missile section container covers including the warhead section container cover. It is also used to handle either of the propulsion section hoist beams, with or without the propulsion section attached.

(2) The four-leg sling is provided for handling missile section containers (loaded or empty) and the PCC and RSGF shelters. Its construction is similar to that of the two-leg sling.

(3) The propulsion section hoisting beams are provided in two sizes. The larger hoisting beam is used for handling the first stage, and the smaller hoisting beam is used for handling the second stage. The hoisting beams are used to--

(a) Lift the propulsion sections to or from their containers.

(b) Position the sections on the launcher.

(c) Align the sections for assembly operations.

(4) The universal sling is provided for lifting either the G&C/A section, the warhead section, or the radar section. Three pairs of mounting holes are provided for lifting strap spacing to permit balanced lifting of the different sections.

1-3. TARGET REFERENCE SCENE PRODUCTION

The reference scene generation facility (RSGF) is used to produce target cartridges. These cartridges, containing reference scenes and target data, are programmed into the on-board computer of the missile to be used in later comparison with the live radar scan from the reentry vehicle. To produce target reference scenes, the RSGF must use information extracted from a target list and an operational data base.

a. Operational Data Base. The operational data base (ODB) contains digitized elevation and topographic feature data stored on discs. These ODB discs are produced by the Defense Mapping Agency (DMA) and distributed to all Pershing II units.

b. Target Cartridges. Target cartridges contain reference scenes and target data. The target cartridge is used to program target data into the missile by inserting it into the GIEU on the erector launcher. From the GIEU, the recorded target data is transferred to the on-board computer in the missile.

c. Target Cartridge Management. The battalion targeting section, headed by the targeting officer, controls and distributes the cartridges as part of their tactical fire direction efforts. A target-to-cartridge assignment list received from the brigade headquarters specifies the arrangement of reference scenes for planned targets on each cartridge to be generated. Cartridges are labeled and become controlled documents. Reference local regulations for the identification, classification, security and control of target cartridges.

(1) Field storage. During field operations, the PCC is the storage location for all cartridges in the platoon's possession. The PCC safe has one drawer with a special rack that can hold a platoon's complement of target cartridges in a readily accessible configuration. Cartridges are removed from this safe only during countdown operations, cartridge exchange, or garrison storage.

(2) Countdown operations. When a cartridge or cartridges is/are moved from the PCC to the firing site, it must be transported by an individual who has a clearance equal to or higher than the security classification of the cartridge or cartridges.

(3) Cartridge exchange. If necessary for target change or maintenance reasons, cartridges will be exchanged using classified material receipts to document the exchange. Defective cartridges found in firing unit countdown operations will be returned to the battalion targeting section for replacement. If the battalion targeting personnel can neither declassify the target data nor restore the cartridge to operational condition, the cartridge must be turned in for destruction as classified material. A replacement cartridge must be generated and fielded.

1-4. COUNTDOWN OPERATIONS

The Pershing II missile system can perform four types of count-downs: standard count, confidence count, quick count, and T-1 count. Each count accomplishes specific functions within the missile, ensuring accomplishment of fire missions. TM 9-1425-386-10-2 provides step-by-step procedures for performing countdowns.

a. Standard Count. The standard count provides the sequence of operations to launch a missile beginning with the missile in the travel configuration on the EL. The purpose of the standard count is to perform all preflight checks and presets while preparing the missile for launch. Normally, the countdown terminates with missile lift-off.

b. Confidence Count. The confidence count is performed to verify equipment. It accomplishes the same sequence of preflight checks and presets as does the standard count. However, the confidence count terminates when ALIGNMENT COMPLETE is indicated on the status display panel. At termination of the confidence count, the missile is placed in a standby or hot hold condition. This allows the missile to undergo a quick count at a later time and be fired. A confidence count is performed periodically to verify system reliability. If needed, a confidence count may be switched to a standard count and the missile launched.

c. Quick Count. The quick count is used for firing a missile after a confidence count has been performed. It begins with the missile in a standby condition and bypasses several of the preflight checks and presets associated with a standard count. The quick count may terminate with missile lift-off or, as with a confidence or standard count, any time before launch sequence initiation. The system may be put in either a standby or a hot hold condition.

d. T-1 Count. The T-1 count is a training and evaluation vehicle. It is a count that allows an individual to see all the missile functions that occur during a standard or quick count, including missile erection, but without firing the missile. This count may be used in the training and evaluation of missile crews as well as in the evaluation of the missile system.

1-5. TWO STAGE FLIGHT SEQUENCE

The two stage flight sequence is shown in figure 1-9.

a. First Stage Ignition. Milliseconds after ignition and lift-off, the missile begins to pitch, or tilt, toward the target at a predetermined rate. Initial thrust is provided by the first stage rocket motor, which burns completely regardless of target range.

b. Coast Period. After the first stage burns out, the missile enters a short coast period before the Pershing airborne computer (PAC) issues the separation signal.

c. First Stage Separation, Second Stage Ignition. The first in-flight separation occurs between the first and second stages. A linear shaped charge in the second stage aft skirt detonates, which causes the first stage to separate from the missile. The second stage then ignites, accelerating the remaining missile sections along the flight path.

d. Second Stage Separation. When the values determined by the on-board computer indicate the missile is on the correct flight path and has reached the necessary velocity and range, an in-flight separation occurs. Explosive devices in the adapter detonate. This causes an in-flight separation between the second stage propulsion section and the reentry vehicle. Simultaneously, the thrust termination ports in the forward end of the second stage rocket motor are activated to terminate the second stage thrust.

e. Reentry and Terminal Guidance. The reentry vehicle, with its on board terminal guidance system, provides guidance through the remaining trajectory to impact. Through the use of thruster assemblies, the reentry vehicle maintains attitude control outside the atmosphere. Air vanes provide control once the reentry vehicle reenters the atmosphere. The radar in the nose of the reentry vehicle is activated during the final portion of flight and scans the terrain in the region of the target area. The computer converts the radar image to a digital representation of the target area, compares this "live scene" to a previously stored reference, computes the adjustments necessary to hit the target, and applies those corrections using air vanes on the reentry vehicle. This "search, compare, correct" routine is repeated several times during the final phases of the trajectory. It provides the same accuracy regardless of range.

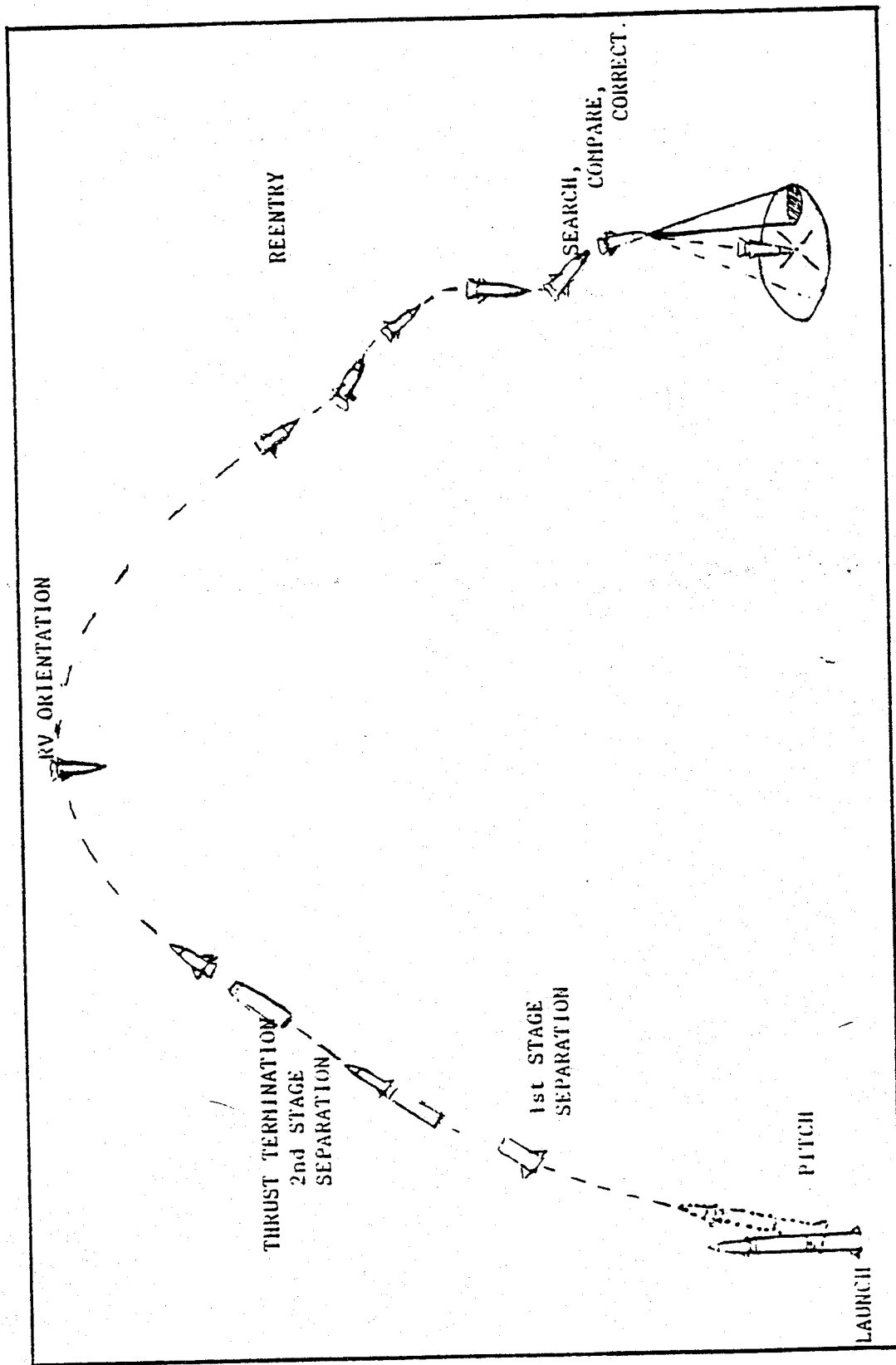

Figure 1-9. Two stage flight sequence.

1-6. SINGLE STAGE FLIGHT SEQUENCE

The single stage flight sequence is very similar to the two-stage flight sequence.

a. First Stage Ignition. First stage ignition occurs as in the two stage flight sequence. After lift-off, the missile maneuvers to a precomputed firing azimuth. The missile continues in flight under pitch and yaw control of a swivel nozzle and roll control of the first stage air vanes (para 1-2a). The first stage motor burns until the proper velocity is achieved to allow free-fall onto the target.

b. First Stage Separation. There is no coast period in the single stage flight sequence. Once the proper velocity is reached, the on-board computer issues a cutoff signal. At this time, the thrust reversal system (thrust termination ports) activates, the RV separation system activates, and the RV separates from the first stage at the adapter section.

c. Reentry and terminal guidance. The reentry phases are identical for single stage and two stage flight sequences.

CHAPTER 2
TASKS, ORGANIZATION, KEY PERSONNEL

Section I. TASKS

2-1. MISSION

a. The mission of the field artillery is to destroy, neutralize, or suppress the enemy by cannon, rocket, and missile fire and to help integrate fire support into combined arms operations. Pershing II gives the theater commander the ability to strike targets accurately at great range. Because of the confidence count and standby capabilities of the system, Pershing II units can be ready over long periods to react quickly to fire orders against planned targets.

b. To continue the deterrence role and enhance the system's survivability during periods of increased international tensions or war, Pershing II units will deploy to field locations.

(1) The battalion commander gives each firing battery an area in which to position its elements. Normally, the battalion area will be quite large in order to accommodate the movement of the various elements.

(2) A firing battery occupies three distinct platoon positions separated by a minimum of 3 to 10 kilometers. A light platoon position contains the firing platoon itself and enough communications, operations, and maintenance support for semi-autonomous operations. The platoon leader is the OIC of a light platoon position. A heavy platoon position contains the third firing platoon and the bulk of the communications, operations, maintenance, and headquarters elements. The battery commander is the OIC of the heavy platoon position and, as in all command functions, is responsible for mission accomplishment by all elements of the battery.

(3) Movement to initial field positions is directed by an Emergency Action Message received by the Battalion Operations Center (BOC). The battalion commander, through the BOC, coordinates and directs the batteries' movements in accordance with SOPs. Normally, a battery will move to the field from garrison in four serials. These include the light firing platoons, the firing element of the heavy platoon, and the headquarters/support element of the heavy platoon.

c. A firing battery may be given any one of the following four tasks to perform in the field:

(1) Assume Quick Reaction Alert (QRA) target coverage immediately upon arriving at the position (immediate coverage). A missile is considered to be in QRA status when it has been prepared for a quick count and has been placed in standby.

(2) Prepare to assume target coverage at a later date (delayed coverage).

(3) Assume a hide configuration (maximize survivability) and await future taskings (no coverage).

(4) Launch a single missile (single target).

2-2. IMMEDIATE COVERAGE

The firing position facilitates the task of immediately assuming QRA target coverage. The firing element will completely emplace the missiles and perform confidence counts in preparation for firing. All of the position's communications assets will be operative and the unit will enter all appropriate communications nets. While the primary task of a unit occupying a firing position is to be prepared to fire its missiles with a minimum reaction time, the defense of the unit must not be forgotten. The QRA target coverage must be assumed as quickly as possible. Vehicles and equipment are positioned to minimize the possibility of detection from the air or from the ground. Communications must be minimized to avoid detection by radio direction finding methods.

2-3. DELAYED COVERAGE

The unit with the task of preparing to assume target coverage some time after deploying occupies a silent firing position. The silent firing position is configured basically the same as the firing position. The primary concern, however, is to avoid detection for as long as possible. Missiles are emplaced, but no countdowns are performed. Whenever possible, radio silence is observed. Normally, generators are not operated and vehicle traffic should be kept to a minimum. Only when directed to assume target coverage will any countdowns be performed. Survivability is the key.

2-4. NO COVERAGE

The hide position is the primary survivability configuration for Pershing II. A unit that is not expected to assume target coverage in the near future will be directed to occupy a hide position. As the name implies, the unit "hides" from the enemy. A tight vehicle configuration is most commonly employed. Erector launchers are not emplaced. Radio silence is observed unless the hide task is changed or cancelled. The unit may be tasked to fire single missiles from an external firing point. The equipment necessary to fire a single missile must be positioned to facilitate displacement and firing.

2-5. SINGLE TARGET

Single missiles may be fired from a unit's current position or, if time is available and the tactical situation permits, from an external firing point (EFP). An EFP should be located at least 5 kilometers from the unit's principal position. It should provide adequate cover and

concealment from enemy detection. The purpose of the EFP is to avoid compromising the main platoon position and to enhance survivability. Care should be taken to avoid compromising the location of the EFP or the main platoon position during organization of, or movement to, the EFP.

Section II. ORGANIZATION

2.6 ORGANIZATION

a. The Pershing II Firing Battery (fig 2-1) is organized with a battery headquarters, an operations/communications platoon, three firing platoons, and a support platoon.

b. The battery headquarters (fig 2-2) contains the personnel and equipment to provide

- o command and control,
- o personnel services,
- o supply support,
- o nuclear surety administration,
- o nuclear, biological, and chemical defense and detection expertise,
- o and food service support

to the subordinate units of the battery.

c. The operations/communications platoon (fig 2-3) provides the personnel and equipment required to direct missile operations, maintain the battery crypto account, and direct the employment of communications assets.

d. The three firing platoons (fig 2-4) deploy, maintain, secure, and simultaneously fire three Pershing missiles. Personnel and equipment are provided to transport and assemble the missiles, input targeting data, operate the platoon control central (PCC) which controls missile launching, launch missiles, maintain missiles, secure nuclear weapons, and secure the position area. Administration, supply, food service, communications, and maintenance support are provided by the battery.

e. The support platoon (fig 2-5) manages all aspects of unit maintenance and directly supervises the distribution of POL. The platoon has two sections; automotive maintenance and missile maintenance. During field operations, personnel from the maintenance sections are deployed with the firing platoons.

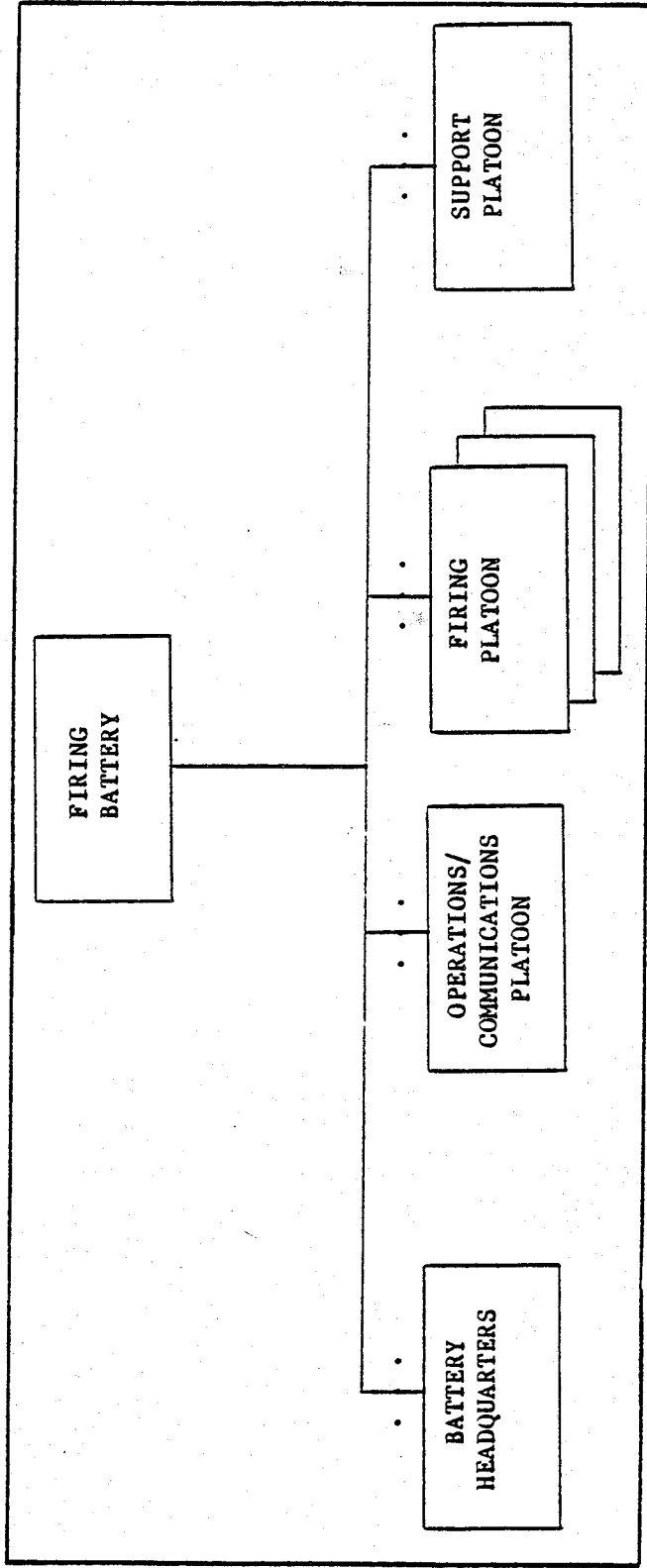

Figure 2-1. Firing battery organization.

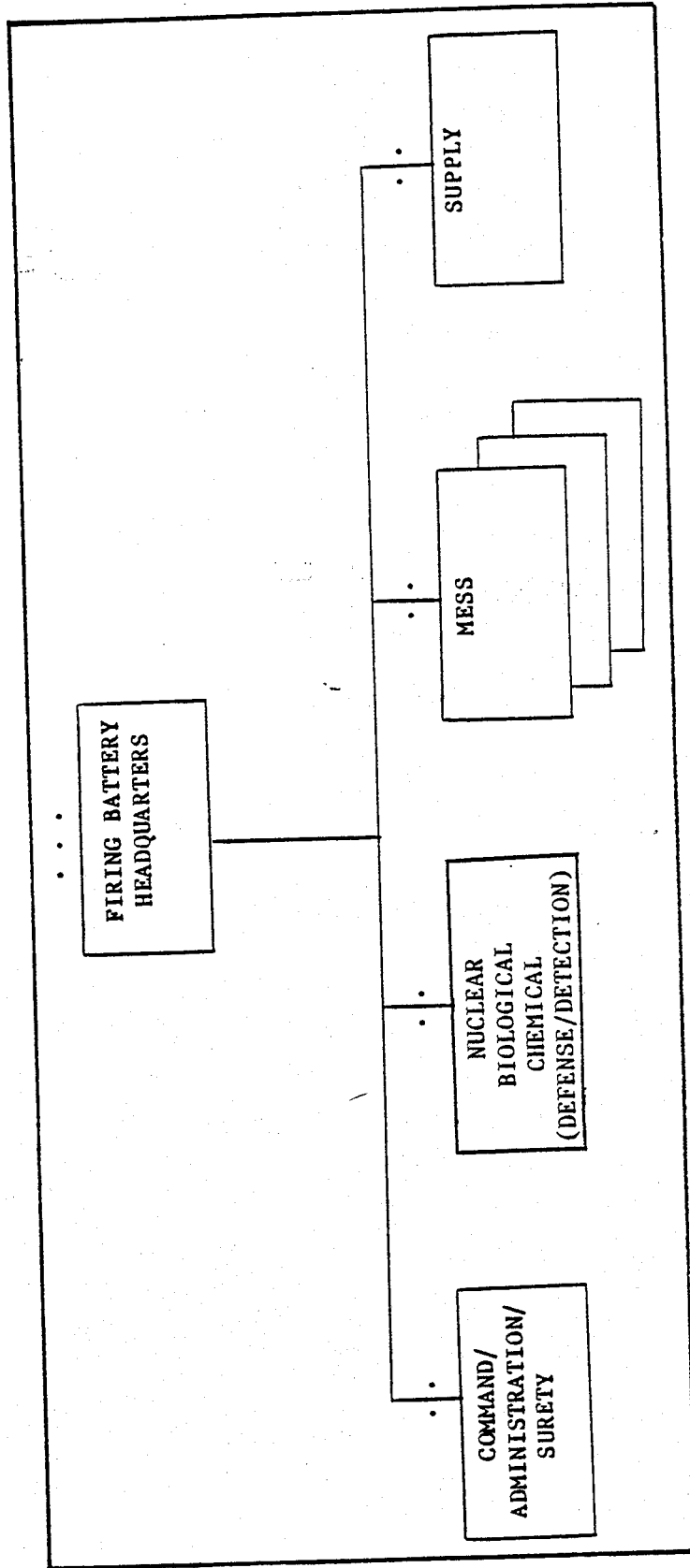

Figure 2-2. Battery headquarters organization.

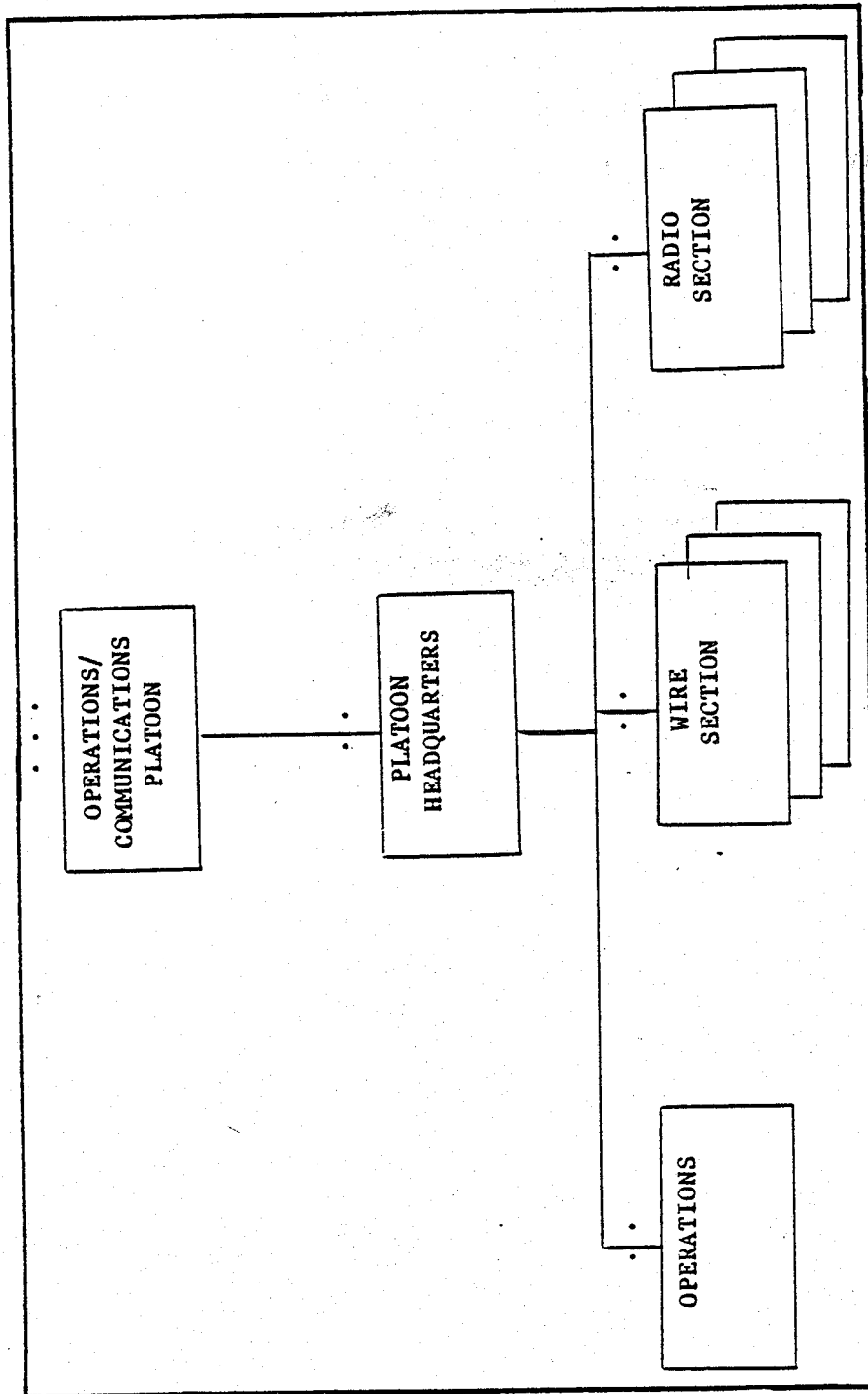

Figure 2-3. Operations/communications platoon organization.

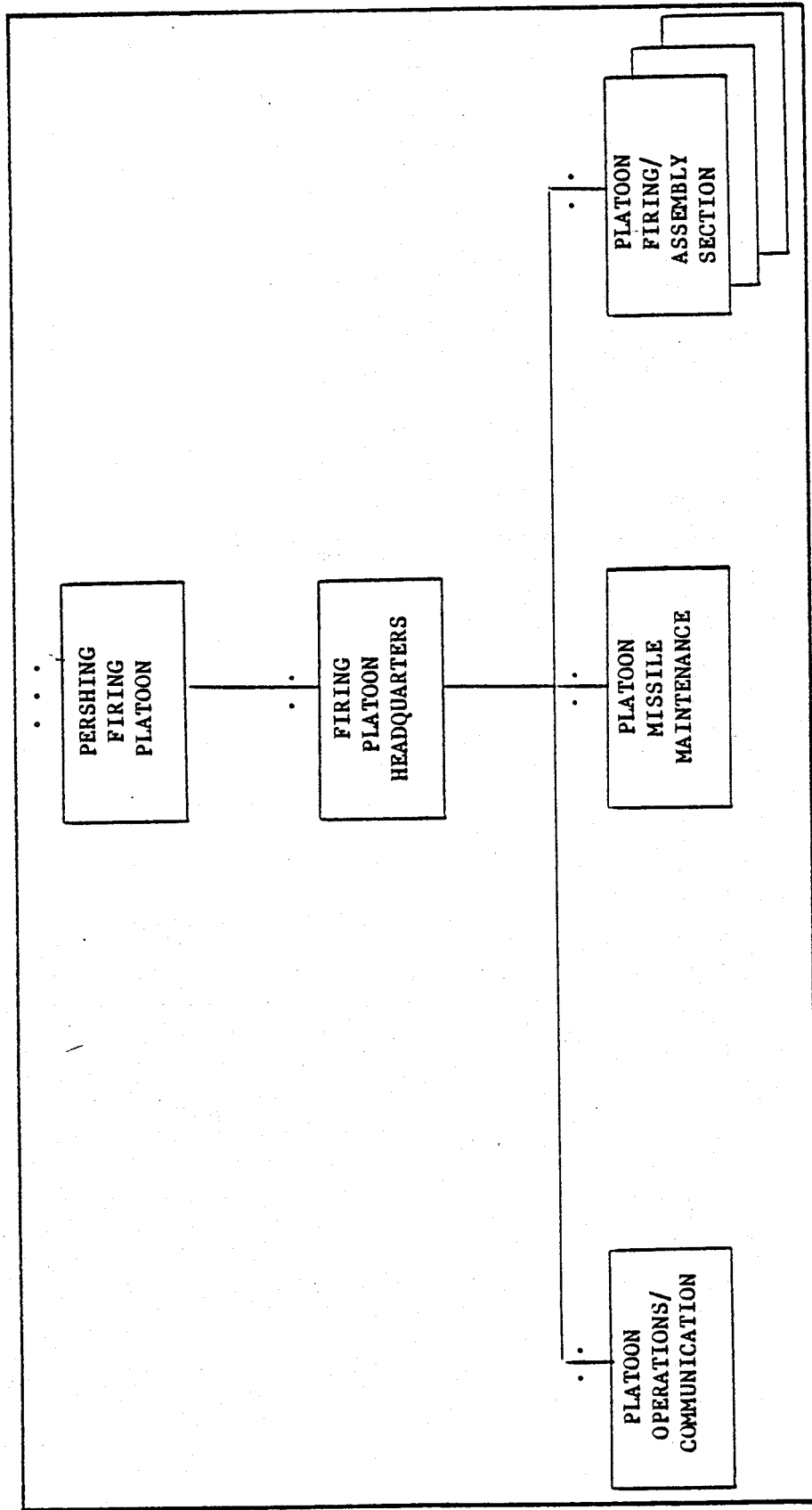

Figure 2-4. Firing platoon organization.

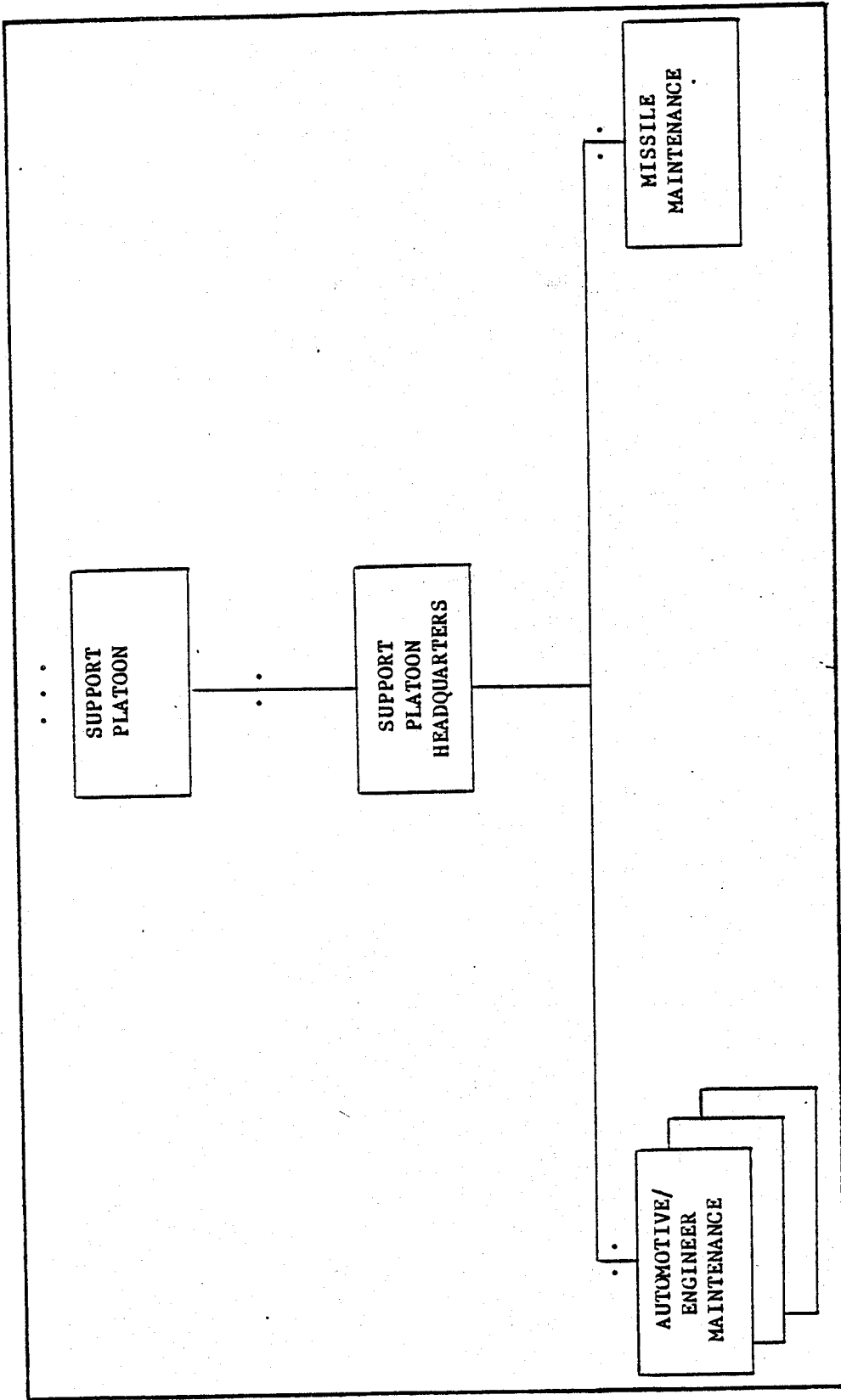

Figure 2-5. Support platoon organization.

Section III. KEY PERSONNEL

2-7. BATTERY COMMANDER

The battery commander (MAJ, 13C) is ultimately responsible for everything the battery does or fails to do. He ensures mission accomplishment. Some of the battery commander's responsibilities follow.

- a. Perform reconnaissance and selection of battery areas which afford mission accomplishment while providing for survivability.
- b. Plan specific actions which will enhance the battery's survivability.
- c. Plan unit marches and movements.
- d. Supervise the security, preparation, and delivery of nuclear weapons.
- e. Keep the battalion commander and battery personnel informed.
- f. Establish and maintain communications and electronics security.
- g. Logistical planning for battery supply and maintenance.
- h. Manage the battery's personnel reliability program (PRP).
- i. Ensure that all battery personnel are trained for combat.
- j. Ensure that all battery equipment is maintained in accordance with applicable technical publications.

The battery commander must respond to calls for fire directly from the theater combined headquarters, joint headquarters, and Army headquarters under extraordinary rules and procedures. He is directly responsible for the movement, employment, and firing of his missiles, which are located in three separate firing locations.

2-8. EXECUTIVE OFFICER

The executive officer (CPT, 13C) is the battery commander's principal assistant and acts for the commander in his absence. He assists the commander in command and control of an organization spread over three locations. The executive officer coordinates and manages the battery's unit maintenance. He also performs supervisory duties on shift in the battery control central (BCC) to facilitate 24-hour sustained operations. His duties include the following.

- a. Ensure that timely and accurate fires are delivered by all firing platoons.

b. Ensure that before, during, and after operation maintenance is performed in accordance with exact procedures stated in technical manuals.

c. Ensure that position area improvement is continuous.

d. Ensure that intrabattery communications are maintained.

e. Ensure that all safety procedures are followed.

f. Perform/supervise destruction to prevent enemy use procedures for battery equipment.

g. Supervise nuclear weapon release procedures.

h. Perform courier officer/convoy commander duties.

2-9. OPERATIONS OFFICER

The operations officer (CPT, 13C), assisted by the operations sergeant (E-7, 15E), performs the same functions for the battery as the S2, S3, and CESO do for the battalion. As a key decision maker during normal firing operations, he establishes and maintains coverage on targets assigned to the battery. He is the platoon leader for the operations/communications platoon. His other responsibilities include the following.

a. Maintain status of nine missiles in three separate locations.

b. Assign targets and target data to include a real-time inventory of reference scenes.

c. Maintain control over PAL and EMAS material.

d. Coordinate battery ammunition resupply and special weapons security.

e. Coordinate security with supporting infantry personnel.

f. Perform/supervise destruction to prevent enemy use procedures for battery equipment.

g. Perform/supervise nuclear weapon release procedures.

h. Perform training officer functions.

i. Control all classified documents and COMSEC materials.

j. Provide for continuous BCC operations.

k. Ensure proper use of wire and radio nets.

- l. Ensure that accurate records of missions are maintained.
- m. Perform courier officer/convoy commander duties.
- n. Work shifts as BCC OIC.

2-10. FIRING PLATOON LEADER

The firing platoon leader (CPT, 13C) performs the same functions for the firing platoon, with the exception of administering the Uniform Code of Military Justice (UCMJ), as the battery commander does for the battery. In addition to being responsible for the platoon's performance, his other responsibilities include the following.

- a. Select suitable positions for the platoon to occupy.
- b. Thoroughly train the advance party.
- c. Perform courier officer/convoy commander duties.
- d. Supervise special weapons operations.
- e. Perform/supervise nuclear weapons release procedures.
- f. Derive pace data to launch points for use in preparing manual data entries (MDEs).
- g. Verify MDE.
- h. Thoroughly train the missile crews.
- i. Manage platoon equipment maintenance.
- j. Employ and control platoon communications assets.
- k. Employ and control platoon security assets.
- l. Work shift in the PCC.
- m. Ensure continuous position improvement.
- n. Perform destruction to prevent enemy use for platoon equipment.

2-11. FIRE CONTROL OFFICER

The fire control officer (LT, 13C) is the principal assistant to the firing platoon leader. While his principal place of duty is in the PCC, the fire control officer must be prepared to act for the platoon leader in his absence. His duties include the following.

- a. Work shift in the PCC.
- b. Supervise PCC operations including PAL, safe/arm, countdown, and launch procedures.
- c. Prepare MDEs.
- d. Compute launch data and verify target cartridges by PID.
- e. Secure and control classified documents within the platoon.
- f. Perform/supervise nuclear weapons release procedures.
- g. Develop and conduct the training program for PCC personnel.
- h. Move the platoon to the next location on order.
- i. Ensure continuous PCC operations.
- j. Ensure proper use of wire and radio nets.
- k. Ensure that accurate PCC records of missions are maintained.
- l. Perform courier officer/convoy commander duties.
- m. Perform destruction to prevent enemy use for platoon equipment.

2-12. SUPPORT PLATOON LEADER

The support platoon leader (LT, 13C), assisted by the senior maintenance supervisor (E-7, 63B), supervises and trains the support platoon. His duties include the following.

- a. Advise the battery commander on the formation of his maintenance program.
- b. Execute the battery commander's maintenance program.
- c. Advise the battery commander and executive officer on the maintenance status of battery equipment and provide information for readiness reports.
- d. Manage the battery's PLL and POL resources.
- e. Perform courier officer/convoy commander duties.

2-13. MISSILE MAINTENANCE TECHNICIAN

The missile maintenance technician (WO, 214EO) is responsible for the supervision of all scheduled and corrective missile maintenance and

liaison with the forward support company elements supporting his platoon. His duties include the following.

- a. Maintain platoon missile equipment, maintenance records, and status reports.
- b. Coordinate maintenance beyond his capabilities with the support platoon leader and executive officer.
- c. Assist platoon leader with position selection.
- d. Assist platoon leader during special weapons operations.
- e. Provide technical assistance/advice during missile operations (emplacement, counting, firing, march order, assembly).
- f. Perform courier officer/convoy commander duties.
- g. Perform destruction to prevent enemy use for platoon equipment.

2-14. FIRST SERGEANT

The first sergeant (E-8, 13Y) is the battery commander's principal enlisted assistant. His responsibilities include the following.

- a. Ensure that enlisted supervisors are adequately trained.
- b. Ensure that administrative and personnel actions within the battery are handled efficiently.
- c. Maintain status of all assigned enlisted personnel.
- d. Train enlisted members of the heavy position advance party.
- e. Assemble the heavy position advance party.
- f. Assist in reconnaissance and selection of battery areas.
- g. Establish the track plan for occupation of the heavy position.
- h. Supervise occupation of and position support vehicles in the heavy position.
- i. Develop and brief the heavy position defense plan.
- j. Designate and rehearse the heavy position reaction force.
- k. Detail personnel to perform support functions in the heavy position (perimeter defense, sanitation, kitchen police).
- l. Coordinate administrative and logistical support.

m. Ensure that the light platoons have adequate defense plans, logistical support, etc.

n. Perform duties as courier officer/convoy commander.

2-15. FIRING PLATOON SERGEANT

The firing platoon sergeant (E-7, 15E) is the firing platoon leader's principal enlisted assistant. Just as the platoon leader functions as the commander in his position, the platoon sergeant functions as the first sergeant. His responsibilities include the following.

a. Ensure that all enlisted personnel of the platoon are adequately trained.

b. Assist in reconnaissance and selection of platoon positions.

c. Supervise the security sweep of the platoon position.

d. Establish a track plan for occupation of the platoon position.

e. Supervise occupation of and position support vehicles.

f. Develop and brief the platoon position defense plan.

g. Designate and rehearse the reaction force.

h. Detail personnel to perform support functions.

i. Supervise the development of range cards for crew-served weapons.

j. Advise the chief of section.

k. Perform destruction to prevent enemy use for platoon equipment.

l. Perform duties as courier officer/convoy commander.

2-16. FIRING PLATOON CHIEF OF SECTION

The firing platoon chief of section (E-6, 15E) is the platoon sergeant's principal assistant. He deals directly with missile operations. His duties include the following.

a. Ensure that all personnel in his section are properly trained.

b. Ensure readiness of his missiles.

c. Ensure that during countdown/firing all crew duties are performed.

- d. Ensure that all prefiring checks are accomplished.
- e. Ensure that all section equipment is on hand and properly maintained.
- f. Ensure that during missile assembly/disassembly all crew duties are performed.
- g. Prepare range cards for crew-served weapons.
- h. Supervise the preparation of fighting platoons for both individual and crew-served weapons.
- i. Be familiar with the position defense plan.
- j. Implement his portion of the defense plan.
- k. Perform duties as safety NCO.
- l. Perform destruction to prevent enemy use for platoon equipment.
- m. Perform duties as special weapons custodial agent.

CHAPTER 3
RECONNAISSANCE, SELECTION, AND OCCUPATION OF POSITION

Section I. RSOP CONCEPTS

3-1. GENERAL

On the battlefield, a sophisticated enemy is capable of locating and engaging a battery/platoon in a variety of ways. To survive, we may be required to move frequently. Frequent movement, however, reduces responsiveness and necessitates greater reliance on other units to assume the mission during displacement. To minimize movement time, all key personnel must be capable of performing the reconnaissance, selection, organization, march, and occupation tasks quickly and efficiently. The keys to successful reconnaissance, selection, and occupation of position (RSOP) are discipline and team effort, which come from frequent and effective training.

3-2. CONSIDERATIONS

The headquarters controlling the movement of the battery directs the essential elements of the movement--when, where, and how. The battery commander/platoon leader must anticipate movement and plan in advance for displacement to new, alternate or supplementary positions. The battery commander should advise the controlling headquarters of any factors to be considered in determining the who, when, where, and how of the movement. The BC must provide for coordination of survey support to platoons and consider the factors of mission, enemy, terrain, troops available, and time (METT-T) when selecting positions for his area of operations:

- Mission: ◦ Is the unit to operate in the hide, silent, or firing mode?
- Enemy: ◦ What is the current threat?
- Terrain: ◦ Can the unit communicate with higher and lower elements?
- Does the terrain support signal security (SIGSEC)?
- Does the terrain offer cover and concealment?
- Is the terrain defensible?
- Will the terrain support movement of the unit's equipment under all weather conditions?

Troops Available: ° Does the unit have enough troops to defend the position and remain mission capable?

Time: ° How much time does the unit have to accomplish the mission?

Section II. RECONNAISSANCE AND THE ADVANCE PARTY

3-3. DEFINITION

Reconnaissance is the examination of terrain to determine its suitability for accomplishment of the battery mission.

3-4. RECEIPT OF ORDER

The battery commander/platoon leader may receive displacement orders ranging from a five-paragraph operation order to a simple authenticated radio message. He is given, or selects himself, the general location of his new position, the time to depart and/or be in the new position, and the routes to be used.

3-5. METHODS OF RECONNAISSANCE

a. Map Reconnaissance. Once the battery commander has been assigned his "goose egg" he identifies all potential positions within his allocated area, as well as routes to those positions. He then assigns areas within which the platoon leaders will perform detailed reconnaissance. A "line of sight" profile sketch may be included as part of the map reconnaissance to preclude problems with FM communications between positions.

b. Air Reconnaissance. Air reconnaissance is a useful supplement to the map reconnaissance. It decreases the time required to assess a large battery position area. Care should be taken to avoid disclosure of position areas to enemy covert forces. When performing aerial reconnaissance, a commander should look for an area that provides a maximum number of launch and hide positions while avoiding open areas. He should concentrate on wooded or urban areas which are defensible and which permit maximum concealment of firing positions.

c. Ground Reconnaissance. A ground reconnaissance normally follows a map reconnaissance. This is the best method of determining the suitability of routes to be traveled and positions to be occupied. The actual conditions of routes and terrain patterns within the proposed area are seen as they exist. Before departure, the platoon leader must give key information to his second in command, to include the following:

- (1) Location of the new position area.
- (2) Possible routes.

(3) Mission and enemy situation.

(4) Any peculiar aspects of positions and/or routes if known.

He goes to each of the positions he has identified through map or aerial reconnaissance. A survey team may go with the platoon leader. While moving, he verifies the suitability of the routes in accordance with bridge and road classifications, location of obstacles, likely ambush sites, etc. After the reconnaissance, he should return by an alternate route to verify its suitability for convoys if needed. Planning the ground reconnaissance must include measures to avoid detection and location of future positions by the enemy.

Note. Each method of reconnaissance offers the BC/PLT LDR a different but complementary perspective. At times, all three methods may be used. In most instances, the BC/PLT LDR performs a map reconnaissance, selects a tentative route, and then conducts a ground reconnaissance.

3-6. PLANNING THE RECONNAISSANCE

a. In a fast-moving tactical situation, the time available for planning the reconnaissance, assembling the party, and conducting the RSOP may be only a few minutes. The primary and alternate routes and distances to the new position area must be considered prior to departure and briefed to the XO/FCO.

b. The organization of the advance party must be tailored. The PLT LDR/enlisted assistant takes only route guides and personnel and equipment necessary for preparation of the position for occupation. These personnel also provide their own defense and initial defense of the new position area.

c. A standard nucleus of advance party personnel should be established. The equipment required to prepare a new position should be preloaded or identified and maintained in such a manner that it can be located and loaded without delay.

3-7. ASSEMBLING THE PARTY

For either a deliberate or a hasty occupation, a prearranged signal or procedures should be used to alert and assemble the advance party. The signal should be specified in the unit SOP, which should also list the personnel, equipment, vehicles, and place of assembly.

3-8. ORGANIZATION OF THE ADVANCE PARTY

The makeup of the party is determined by the PLT LDR and PLT SGT based on the tactical situation and assets available.

a. The advance party will be preceded to the position area by the supporting infantry contingent. The infantry performs a reconnaissance of the selected route to ensure it is free of threat forces. To avoid

compromising actual positions, the infantry does not enter the position but performs a security sweep around the position, sets up LPs/OPs, and begins patrolling. Communications must be maintained between the infantry, advance party, and main body.

b. The size of the advance party will be kept to a minimum to avoid detection. Normally, platoon leaders lead the advance parties which organize the new platoon positions. During the organization phase, adequate security should be maintained to protect against a small, squad-size force. Positive measures must be taken to conceal the location of the unit and to avoid detection. An NBC survey monitoring team should go with the advance party to check for NBC contamination if NBC warfare has been initiated. Upon arrival at the position, the advance party should be in the appropriate NBC protective posture as dictated by the situation. Initially, the survey monitor team takes environmental samples of the entrance to the area. The results of the sampling are brought to the officer in charge to determine whether the position is tenable and if any change to the NBC protective posture is necessary. If the position is tenable, the security team sweeps the area and establishes a defensive perimeter.

3-8. EXECUTING THE RECONNAISSANCE

a. Prior to departing, the platoon leader must brief key personnel and advance party members. This briefing should cover:

(1) Situation.

(a) Enemy situation. Rear area activity, major avenues of approach, air activity, and potential ambush sites.

(b) Friendly situation. Changes in tactical mission and location of adjacent units.

(2) Mission. Changes in mission of the platoon, if any. (i.e., targeting, assignments and coverage, generation levels, etc.)

(3) Execution.

(a) Concept of operation. General location of platoon positions, routes, and order of march.

(b) Coordinating instructions. Location of start point, release point, and start point time if known/used.

(c) Mission oriented protective posture (MOPP) status.

(4) Administration and logistics. When and where to feed personnel and priority for maintenance and recovery.

(5) Command and signal.

(a) Command. Changes in location of battalion/battery command post (CP).

(b) Signal. Movement radio frequency and net control restrictions.

b. After being briefed by the PLT LDR, the FCO/PLT SGT should brief his remaining key personnel on the following:

- (1) Tactical situation.
- (2) Routes to be used.
- (3) Any anticipated problems.
- (4) Movement time, if known.

c. After making a map reconnaissance, completing his planning, and briefing necessary personnel, the PLT LDR is ready to proceed. The primary purpose of the route reconnaissance is to verify the suitability of the primary route. He also checks--

- (1) Alternate routes (time permitting).
- (2) Road conditions and bridge classifications.
- (3) Cover and concealment.
- (4) Location of obstacles.
- (5) Likely ambush sites.
- (6) Time required.
- (7) Distance.
- (8) Likely position areas along the route.

Section III. SELECTING THE POSITION

3-9. BASIC TYPES OF POSITIONS

The platoon leader must select three basic types of positions.

a. Primary position. The position from which a platoon intends to accomplish its assigned mission.

b. Alternate position. The position to which the entire platoon moves in the event its primary position becomes untenable. Since the platoon will continue its mission from the alternate position, it must

meet the same requirements as the primary position and should be far enough away that the battery can escape the effects of enemy indirect fire on the primary position. It should be reconnoitered and prepared for occupation as time permits. Each section chief must know the route to the alternate position because movement to that position may be by section.

c. Supplementary position. A position selected for accomplishment of a specific mission, such as an external firing point.

d. Heavy vs light position. The battery headquarters is collocated with a firing platoon in the heavy platoon position. The battery headquarters should be located to provide the best communications with the subordinate firing platoons and battalion headquarters. The other two firing platoons are located in light platoon positions. Light platoon area selection must consider that fewer resources are available for defense. To enhance survivability, a minimum dispersal of three to ten kilometers between each firing platoon position is desired dependant on the expected threat.

3-10. SPECIFIC TYPES OF POSITIONS

In addition to the three types of positions mentioned before, the platoon leader must select positions which support the tasks assigned: firing, silent firing, hide, external firing and, if required, an assembly area.

a. Firing position. Accomplishing the mission of firing missiles must take precedence when selecting a firing position. While overhead cover is essential for survival, it must not interfere with a missile during lift off. Therefore, a minimum of a ten-foot hole in the overhead cover must be present over each launch point. The position must be large enough to enable positioning ancillary equipment out of the blast zones, yet small enough to be defensible. An established road network capable of supporting the weight of an erector launcher with missile and affording separate entry and exit routes should be used when possible. Missiles must be positioned within the constraints specified by the appropriate technical manuals. Ancillary vehicles are normally positioned so as to protect the missiles from direct fire and ground observation from outside the position.

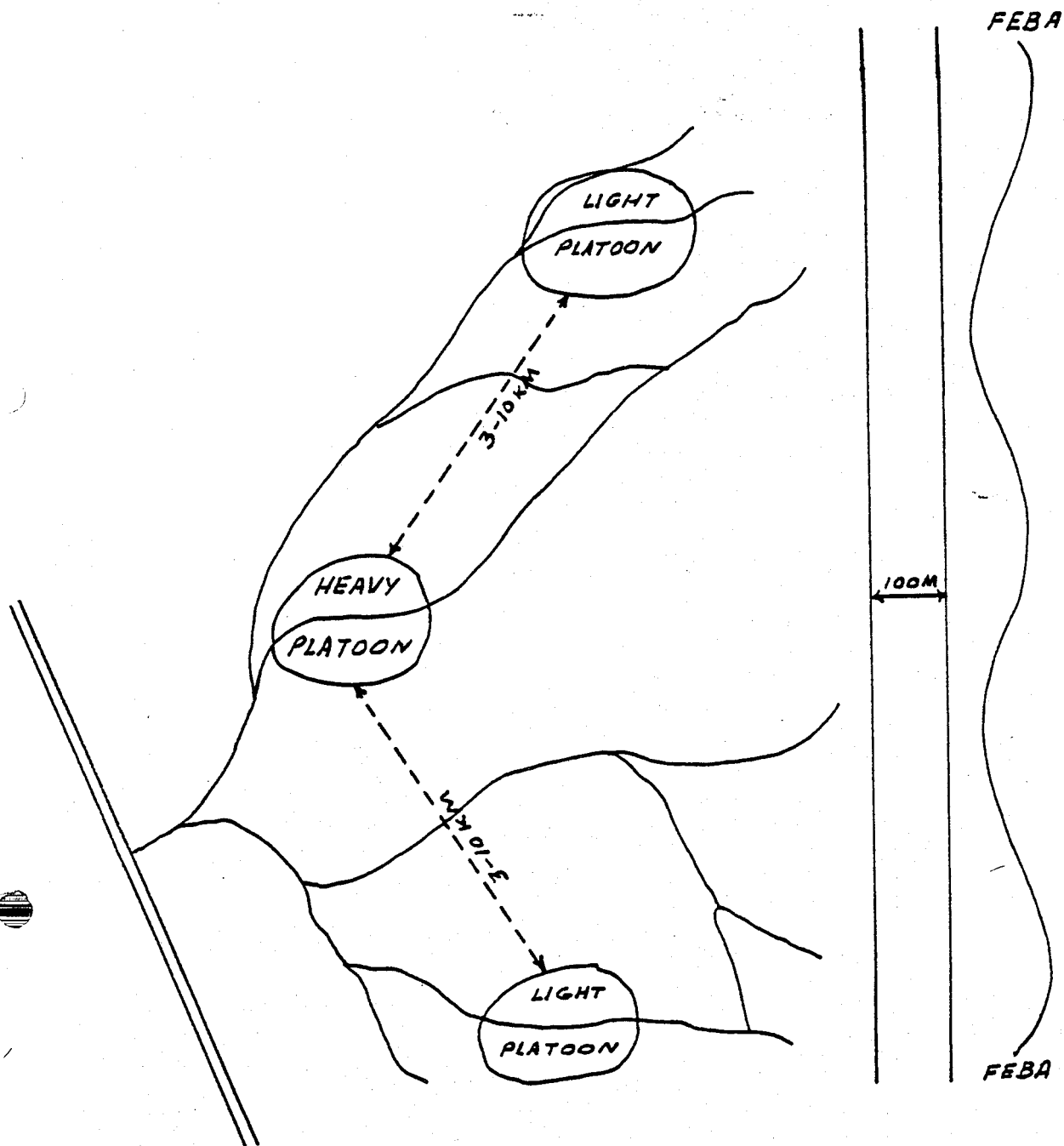

Note: Platoon positions are roughly parallel to the forward edge of the battle area (FEBA) due to signal security considerations.

Figure 3-1. Area assignments by the battery commander.

b. Silent firing position. The silent firing position increases survivability while affording a minimum of response time for performance of a fire mission. The RSOP considerations are the same as for a firing position. The equipment will be emplaced for firing, however, there will be no power generation. Passive defense measures are strictly enforced, as for the hide position.

c. Hide position. When a platoon is not required to assume target coverage, survival becomes the primary task. To accomplish this task, all measures of passive defense must be strictly followed, as prescribed in chapter 4. The RSOP considerations for successful hide operations are as follows:

- (1) Missile equipment is not positioned for firing.
- (2) Equipment is positioned to reduce defense requirements.
- (3) An exclusion area is established for any nuclear weapons present.
- (4) A restricted area for BCC/PCC, single side band (SSB), and tactical satellite (TAC SAT) must be planned.
- (5) The hide position should be close to selected firing positions to minimize the time required to make the transition from hide to firing operations.
- (6) Positioning of equipment should be planned to best facilitate movement of missile equipment out of the position without having to move the entire platoon.
- (7) There should be enough room between vehicles that if one vehicle becomes inoperable, others can get around it.
- (8) Equipment must be concealed from the sides as well as from overhead with enough cover to prevent detection by observers and side-looking airborne radar. An optimum hide position provides the flexibility to expand to a silent firing or firing position without moving the platoon to a different area.

d. External firing point. An external firing point (EFP) is a position to which one missile is taken and prepared for launch. Covert operations are absolutely essential. Only the equipment necessary to launch the missile (including communications and operations equipment), provide security, and communicate is taken. An advance party is not needed in most cases. The position is much smaller than that of a firing platoon because of the minimal equipment in the position. Noise and light discipline is an absolute must during all aspects of EFP operations.

e. Assembly areas. After initial rounds are fired, a consolidation of battery assets may be required to continue operations. The assembly area is designed to facilitate missile and warhead resupply as well as missile assembly operations before the platoons, or sections of platoons, proceed to occupy additional firing positions.

(1) Many of the criteria for the selection and occupation of firing positions apply to assembly areas. The major exception is that the mission to be performed normally does not include the firing of missiles. A long, wide, level, easily trafficable area must be selected to facilitate resupply and missile assembly operations and to hold remaining assets of the entire battery. The area also must provide necessary concealment.

(2) The size of the assembly area depends on the amount of equipment it will contain. For a complete firing battery, the position will be extremely large. Extra fighting positions on the defensive perimeter may be necessary.

f. Differences between positions. Figure 3-2 graphically depicts a comparison of the five types of positions a Pershing unit may have to occupy.

	HIDE	SILENT FIRING	FIRING	EFP	ASSEMBLY AREA
MISSILES EMPLACED	NO	YES	YES	YES	NO
CONFIDENCE COUNTS	NO	NO	YES	NO	NO
STANDARD COUNTS	NO	NO	NO	YES	NO
COMMUNICATIONS ASSETS	FM ONLY	FM ONLY	ALL	ALL	FM ONLY
MESSING	COLD	COLD	HOT	COLD	COLD
OVERHEAD COVER	FULL	HOLES	HOLES	HOLES	FULL
GENERATORS	1.5 kw	1.5 kw	ALL	ALL	1.5 kw
CAMOUFLAGE	NATURAL AND MAN- MADE	NATURAL AND MAN- MADE	NATURAL AND MAN- MADE	NATURAL	NATURAL AND MAN- MADE

Figure 3-2. Comparison of positions.

Section IV. ORGANIZING THE POSITION

Organization of the platoon position includes--

- Designating locations of vehicles, facilities, and equipment.
- Briefing vehicle guides.
- Preparing the track plan.
- Designating vehicle order of march for the main body.
- Designating chemical agent sampling locations.
- Preparing the defense plan.
- Preparing a plan for internal wire communications. When time permits, wire should be laid before arrival of the main body.

3-11. LAUNCH POINTS IDENTIFICATION

A firing position must allow for safe and unobstructed launch of all missiles. Availability of an adequate launch area drives the selection of the position. (A launch area in a firing position normally contains three missiles on erector launchers.) The major considerations in launch area selection include the following:

- Launch paths--overhead cover must not obstruct missile firing.
- Blast zones--the area must be large enough to allow equipment emplacement away from the missile blast. See TM 9-1424-386-10-2. Blast effects not only on personnel, but also on low lying vegetation should be considered.
- Terrain slope tolerance--A slope of 6° or less is required for erector launchers.
- Erector launchers--The ELs must be concealed from air and ground observation. Missiles should be protected from direct engagement by small arms fire outside the perimeter.
- Emplacement positions for erector launchers must be capable of supporting the weight of the vehicle and allow erection of the missile.
- Distance between launch points cannot exceed interconnecting cable lengths.

3-12. FACILITIES AND EQUIPMENT

The current situation dictates the need for tactical dispersion of equipment, natural cover and concealment, and other passive defense

measures in selecting the position. Capabilities and limitations of communications equipment must be considered when siting the platoon headquarters. The BCC/PCC and defense control center (DCC) positions must be selected to facilitate radio communications as well as landline communications to the defensive perimeter and the launch area. The position must facilitate missile section and RV loading and mating operations. There should be room to position vehicles delivering sections and RVs, as well as to reposition the materiel-handling crane mounted on the prime mover. The position should facilitate generator refueling as required. The position must facilitate both active and passive defense measures. A defensible position should--

- o Deny enemy observation during occupation.
- o Provide natural concealment.
- o Provide multiple entry and exit routes.
- o Permit the unit to mask communications emitters behind hill masses.
- o Provide adequate fields of fire and visibility to properly defend the position.
- o Permit emplacement of all equipment in a small area so that a minimum number of fighting positions can adequately support a defensive perimeter.

3-13. TRACK PLAN AND VEHICLE ORDER OF MARCH

The area must allow vehicles to get in and out of it. A Pershing II platoon has a significant amount of large, wide, and heavy vehicles. Tree density, softness of ground, and slope of terrain, must be considered. Missiles on erector launchers will probably have to remain on hard surface, or semihard surface roads because of their extreme weight. There should be sufficient drainage within the area to avoid a platoon getting "bogged down" during heavy rain. The track plan should clearly sketch how vehicles will move in and out of the position. It should also identify the main body order of march, the convoy release point, and the vehicle guide pickup point. Vehicle order of march should be communicated to the main body before movement and should facilitate occupation.

3-14. DEFENSE PLAN

The defense plan should be a sketch of the defensive perimeter, observation and listening posts, patrol areas, minefields, and early warning measures. The defense plan must provide for 360° defense of the perimeter as well as defense in depth. Missiles must be protected from small-arms fire from outside the perimeter. Auxiliary vehicles may be used for protection of missiles and be moved out of blast zones before launch. Chapter 4 presents detailed defensive considerations.

3-15. INTERNAL WIRE PLAN

The wire plan should identify each TA 312 telephone and termination point within the heavy or light platoon area. Perimeter positions will have wire communications with the DCC switchboard. Wire communications will be maintained between the DCC and the BCC/PCC, the mess facility, observation and listening posts (OPs/LPs will have to rely on FM communications during initial emplacement), and the exclusion area gate. The BCC/DCC must keep direct wire communications with all radio facilities. If the reaction forces are not at the DCC, communications must be maintained from the DCC to these forces.

3-16. VEHICLE GUIDES

Guides must know where each vehicle and facility will be located as specified by the track plan. The guides must also know in which direction to point the vehicle to facilitate departing the area. Guides must walk the route from the pickup point to the vehicle/facility location and ensure that the route is unobstructed. When moving vehicles into the position area, guides begin controlling vehicle movement at the pickup point. Vehicles must be moved off the road as soon as possible to avoid detection. When there are insufficient guides for each vehicle, guides should be located for maximum control and to help assistant drivers rapidly position vehicles and equipment.

Section V. TACTICAL MARCHES

3-17. GENERAL

Normally, the firing battery moves by platoon. The movement order for the main body includes start point (SP) and release point (RP) times as well as the order of march. A vehicle from the advance party meets the main body at the RP and leads the convoy to the pickup point. Vehicle guides control vehicle movement from the pickup point to the individual vehicle locations (vehicles carrying warheads require point-guards at this time). The position should be rapidly occupied as specified in the track plan. Units must be extensively drilled on all movement methods to minimize the time the unit is unable to provide fire support. The loading of equipment on vehicles and trailers begins upon receipt of a warning order to move. Consistent with the mission, communications equipment is switched from the static to the mobile mode of operation. Missiles and related equipment should be prepared for transport as soon as possible. There are two primary methods of moving a Pershing unit in a tactical configuration. Each method has its specific advantages and disadvantages. The battery commander/platoon leader decides which method is best.

a. Open column road movement. The open column is used for daylight movements whenever there is an adequate road network that is not overcrowded, when enemy detection is not likely, when time is an important factor, and when there is considerable travel distance involved. Vehicle interval in an open column is generally 100 meters.

(1) Advantages of this method are:

- o Speed (the fastest method of march).
- o Reduced driver fatigue.
- o Improved vision on dusty roads.
- o Ease in passing individual vehicles.
- o Ease in dispersing vehicles as a passive defense measure against an air attack.
- o Less chance of the entire unit being ambushed.

(2) Disadvantages of this method are:

- o Greater column length requires more road space.
- o Other traffic often becomes interspersed in the column.
- o Communication within the column is complicated.

b. Closed column. For closed column movement, the vehicle interval is less than 100 meters. At night, each driver can observe the cat's-eyes of the blackout markers on the vehicle in front of him and maintain an interval of 20 to 50 meters (fig 3-3). If the driver sees two marker lights, the interval is too great. If the driver sees eight marker lights, he is too close. If the driver sees four marker lights, he is maintaining the proper interval. During daylight, closed column is used when there is a need for maximum command and control; e.g., during periods of limited visibility or when moving through built-up or congested areas.

(1) Advantages of this method are:

- o Simplicity of command and control.
- o Reduced column length.
- o Concentration of defensive firepower.

(2) Disadvantages of this method are:

- o Column is vulnerable to enemy observation and attack.
- o Strength and nature of the column are quickly apparent to enemy observers.
- o Convoy speed is reduced.
- o Driver fatigue increases.

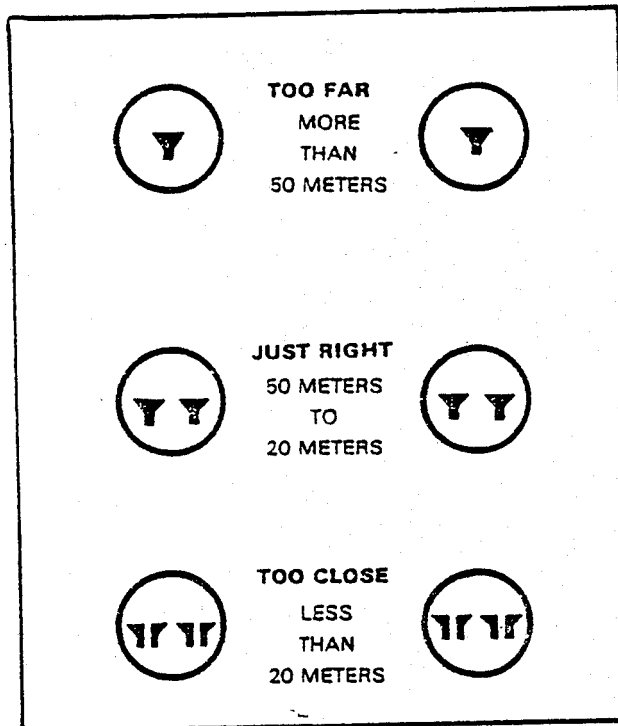

Figure 3-3. Cat's-eyes blackout markers.

3-18. LOADING PLANS/LISTS

a. A loading plan/list is particularly important in sustained combat, and each vehicle should have one. The loading plan should be recorded and graphically illustrated. The loading list need not be graphically illustrated. This helps ensure the unit will close on the new position with all its equipment. Personnel responsible for preparing loading plans/lists should consider the mission, personnel, SOP, and equipment of the battery. Equipment needed first during occupation should be loaded last. Steps in preparing the loading plan/list include:

- (1) Examining the modified tables or organization and equipment (MTOE) to determine the personnel, equipment, and vehicles authorized for each section.
- (2) Examining all tables of distribution and allowances (TDA) property that must be transported by the battery. This equipment should be carried by the section responsible for its use.
- (3) Listing the personnel and equipment to be carried in each vehicle. Equipment should be loaded the same way for each move to aid in identification under blackout conditions. Technical manual guidance, if available, should be followed.

(4) Conducting practice loadings and adjusting the plan if necessary.

(5) Establishing a list of items that must be removed from the vehicle and carried forward if the vehicle becomes disabled during movement.

b. Consistent with mission requirements, vehicles should remain uploaded.

3-19. FINAL PREPARATIONS

a. Preparation for the move should include the following:

(1) Preoperative maintenance checks by vehicle drivers.

(2) Reloading of all off-loaded equipment.

(3) Complete loading of all service elements; e.g., mess, supply, and maintenance.

(4) A briefing by the convoy commander to the drivers covering such subjects as safety and instructions addressed in the march order, the tactical situation, and the mission. Strip maps may be issued at this time.

b. The organization of the march column varies according to the tactical situation and the position area to be occupied. The following points should be considered:

(1) The launchers should be dispersed throughout the entire column with a minimum of one buffer vehicle between missiles.

(2) Vehicles should be arranged in an order that allows speedy, organized occupation of the new position and defense during movement and occupation.

(3) Each vehicle should have an assistant driver. The assistant driver also serves as an air guard.

(4) Machine guns should be distributed evenly through the column and aimed alternately to the left and right sides of the route of march.

(5) Canvas should be removed to allow personnel to have their individual weapons poised to return fire if necessary. Unit SOP should specify if some personnel are to fire on full AUTO and some on SEMIAUTO.

(6) Key personnel should be dispersed throughout the column.

(7) Fire fighting equipment should be positioned behind the last launcher in the convoy (excluding fire extinguishers, which should be with each vehicle/trailer).

(8) A means by which to destroy equipment to prevent enemy use must be readily available.

3-20. CONVOY CONTROL MEASURES

The following control measures help in the movement of the battery:

a. The start point (SP) is normally a geographical feature identifiable on the ground and on a map. The first vehicle of a convoy should cross the SP at the specified time.

b. A checkpoint (CP) is normally a geographical feature identifiable on the ground and on a map. It is used in reporting progress along the route of march.

c. The release point (RP) is normally a geographical feature identifiable on the ground and on a map. The last vehicle of a convoy should cross the RP at a specified time. Guides from the advance party meet the convoy at the release point to lead the vehicles into the new position area.

d. Radio transmissions should be avoided during marches to deny the Threat signal intelligence. Battery SOPs should specify procedures for the use of radios, messengers, flags, whistle and horn signals, pyrotechnic signals, and hand and arm signals (in accordance with applicable STANAG/QSTAGS). Radio transmissions should be as brief as possible. At no time should specific information be broadcast over the radio that could compromise the convoy's location, such as EXITING THE HIGHWAY or PASSING THROUGH TOWN. References for location should be limited to 2 KILOMETERS SOUTHWEST OF CHECKPOINT NOVEMBER KILO, HAVE ARRIVED AT RELEASE POINT, etc.

3-21. MARKING THE ROUTE

Road-guards may be posted at critical locations where elements of the march might make a wrong turn. However, priority consideration must be given to avoiding detection. Provisions should be made to ensure the prompt pickup of the road guards when they are no longer needed. If personnel are not available, route markers can be used. (Care must be given not to compromise the unit's location or identity.) Details concerning traffic control and route markings are in FM 55-30 and FM 19-25.

3-22. CONDUCT OF THE MARCH

The main body of the heavy or light platoon should move at night, if possible, to avoid being located by the enemy. Nuclear convoys must be conducted in accordance with procedures described in chapter 5,

FM 100-50, and local policies. During movement, the enemy must be prevented from following the convoy to the new position. Speed of the convoy and control of civilian vehicles are necessary to avoid detection. Saboteurs and small, unconventional forces must be prevented from effectively engaging units with small-arms fire.

3-23. MARCH DISCIPLINE

a. Convoys may be organized into serials, which are groupings of march units under separate convoy commanders. The size of the serial should be consistent with the mission and tactical situation. For example, a serial may consist of one platoon's vehicles, personnel, and equipment; or it may consist of one firing crew's vehicles, personnel, and equipment. The support personnel and equipment of the battery HQ area may deploy as a separate "admin" serial.

b. Officers and NCOs should ride where they can best control and supervise the march of their units. One of these individuals rides at the head of each serial. The senior person in each vehicle is responsible for ensuring that all orders concerning the march are carried out. All vehicles maintain their order of march unless directed or until circumstances dictate otherwise.

c. The column should keep moving. The unit SOP should prescribe recovery procedures for disabled vehicles. It should also indicate who stops to pick up mission-essential personnel.

d. Normally, halts are not scheduled for tactical marches. If a halt is necessary, a wooded area should be selected as the halting place. Vehicles should be dispersed off the road and concealed.

e. The assistant driver watches for signs, markers, signals, and other traffic. He is also responsible for ensuring the driver is alert and safely operating the vehicle at all times.

f. March discipline is attained through training and internal control. The specific objective of march discipline is to ensure cooperation and effective teamwork by march personnel. Teamwork includes--

- (1) Immediate and effective response to all signals.
- (2) Prompt relaying of all signals.
- (3) Obedience to traffic regulations and to the instructions of traffic control personnel.
- (4) Use of concealment, camouflage, dispersion, radio listening silence, blackout precautions, smoke, and other protective measures against air, ground, and NBC attack.

(5) Maintenance of safe speeds, positioning, and intervals between vehicles within the column.

(6) Recognizing route marking signals/signs.

(7) Use of correct procedures for handling disabled vehicles.

g. Radio contact between lead and trail vehicles, preferably secure, should be provided for convoy control.

3-24. CONTINGENCIES

a. Immediate action procedures. Because of Pershing II nuclear capabilities, it is always a high-priority target for the Threat. A battery can greatly decrease vulnerability to attack by establishing an SOP for immediate actions. The following should be considered:

(1) Enemy situation--type of attack that can be expected.

(2) Organic resources for countering the different types of attack.

(3) Nonorganic support available for countering attacks.

(4) Type of communications to be employed with the immediate actions--flags, radio, arm and hand signals, etc.

(5) How best to protect the unit.

(6) How best to neutralize the attack.

b. March column under air attack. If there is an air attack, the unit should disperse to both sides of the road, if terrain offers cover and/or concealment, dismount, and return fire with individual weapons.

c. Ambush.

(1) There are two types of ambushes: blocked and unblocked. Both must be countered in the same manner--get out of the kill zone, and neutralize the ambushing force with firepower.

(a) Blocked ambush. If the route is blocked, maximum available fire should be placed immediately on the attacking forces. Personnel in the kill zone should immediately dismount and attack as infantry. The portion of the battery not in the kill zone also must react immediately. Unit SOP should clearly detail actions to be taken in this situation.

(b) Unblocked ambush. In an unblocked ambush, the battery should increase its speed and move through the ambush area while placing the maximum amount of small-arms and automatic weapons fire on the attackers.

(2) If the area is identified during the map reconnaissance as a likely ambush site, do not pass through the area.

(3) If the ambush or any other enemy action is of a magnitude that will cause the column to be broken up, individual elements should proceed to the new position or designated rally points on their own as assigned by the unit SOP.

3-25. UNIT MOVEMENT SOP

Establishing and following a realistic movement SOP will ensure personnel are adequately trained to cope with situations that may confront them. As a minimum, the unit SOP should conform to the battalion SOP and cover the following:

- a. Approval authority and requirements for displacing units of the battery for all possible tactical considerations.
- b. Duties of convoy commanders.
- c. Duties of the courier.
- d. Duties of assistant drivers.
- e. Convoy organization.
- f. Weapons and ammunition to be carried by personnel.
- g. Protective equipment to be worn by personnel.
- h. Preparation of vehicles (detailed instructions regarding canvases, windshields, tailgates, tiedown procedures, etc.).
- i. Counterambush action.
- j. Drills in reaction to air or artillery attack.
- k. Security measures (security forces, blackout lights, etc.).
- l. Maintenance and recovery of disabled vehicles.
- m. Establishment of rally points.
- n. Convoy communications.

Section VI. OCCUPATION OF POSITION

3-26. TYPES OF OCCUPATION

a. This section describes two types of occupation--deliberate and hasty. Additionally, the key functions performed in readying the platoon for firing and for sustaining operations are addressed.

b. A deliberate occupation is one that has been planned. An advance party precedes the unit and prepares the position. The occupation may be during daylight hours following a daylight preparation, at night after a daylight preparation or at night following a nighttime preparation. A common error in a deliberate occupation is allowing too much activity during preparation, thereby risking compromise. Only the minimum number of vehicles and personnel should go forward. When the tactical situation allows, a very good method of occupying a new position is to perform the advance preparation prior to darkness and the movement by night. Nighttime movement following a nighttime reconnaissance is often necessary, but it can be more time consuming.

c. The hasty occupation differs from the deliberate occupation mainly in the amount of time available for reconnaissance and preparation. It generally results from unforeseen circumstances and highlights the importance of planning ahead and selecting tentative positions and routes to them.

d. The remainder of this section will be devoted to key elements of the occupations. Details on defense of the battery position and the sequence for position defense are contained in chapter 4.

3-27. DELIBERATE OCCUPATION

a. A guide meets the platoon at the release point and leads the platoon to the entrance of the position area where vehicle guides are waiting to lead the vehicles to their selected locations.

b. The platoon sergeant directs implementation of the security and defense plan as personnel become available.

c. Survey data should be available from external sources or from a hasty survey.

d. Additional considerations for night occupations are:

(1) Light discipline must be practiced. Proper preparation for a night occupation will minimize the need for lights. Vehicle blackout drive and blackout marker lights should be turned off as soon as the ground guide has begun to lead the vehicle into position.

(2) Noise discipline is more important since noise can be heard at much greater distances at night.

(3) The time for occupation is increased.

(4) Each vehicle guide should know where his vehicle is in the order of march to enable the unit to move smoothly into position without halting the column.

(5) Red filtered flashlights are used to lead the vehicles.

CAUTION: Each driver must stop his vehicle whenever he cannot see the light from the guide's flashlight.

(6) Vehicles should not be allowed to move within the position without a guide.

3-28. HASTY OCCUPATION

In a hasty occupation, day or night, the platoon will require more time to occupy because some preparatory tasks cannot be performed during the limited time available for the reconnaissance and selection phase. This may result in some delay in getting the vehicles off the route of march.

3-29. SUSTAINING ACTIONS

a. Once the occupation is completed and the platoon is in QRA posture, sustaining actions begin. They are continuous and accomplished in the priority determined by the battery commander/platoon leader. These actions include:

- (1) Improve position defense plans.
- (2) Improve camouflage.
- (3) Bury and/or overhead wire lines.
- (4) Harden critical elements.
- (5) Reposition vehicles.
- (6) Perform maintenance.
- (7) Rehearse reaction forces.
- (8) Refuel.
- (9) Conduct training.
- (10) Resupply all classes of supply.
- (11) Prepare to march order.

b. Care must be exercised in the manner in which resupply and refueling are conducted, for they can reveal the location of the platoon. If possible, these tasks should be accomplished at night.

c. The advance party should always be prepared to leave at a moment's notice.

CHAPTER 4
DEFENSE

Section I. INTRODUCTION

4-1. GENERAL

Threat forces have significant capabilities against which Pershing II units must be able to defend. Because of the system's firepower capabilities, Pershing II represents a tactical target of highest priority. A major objective of the Threat will be to seek and destroy Pershing's fire support capabilities with air, airborne, and missile forces. Pershing II units that can be located by agents, radio direction finding, long-range patrols, or airborne radar are much more vulnerable to attack. The positioning of Pershing II units well behind the Forward Line Of Own Troops (FLOT) will not present a substantial defense from the threat of attack. To accomplish its mission, a Pershing II unit must be able to--

- Avoid detection.
- Communicate.
- Disperse.
- Improve/harden positions.
- Move.
- Defend against small unit ground attack.
- Defend against airborne attack.
- Defend against air attack.
- Operate in an NBC environment.

4-2. ESTABLISHMENT OF PRIORITIES

Throughout his planning, the platoon leader must consider two possible scenarios and establish his priorities accordingly.

a. The platoon leader instructed to continue his mission in the position despite hostile fire might establish the following tasks in the priority indicated.

- (1) Camouflage.
- (2) Harden critical items of equipment.
- (3) Prepare individual foxholes.

(4) Prepare defensive positions.

(5) Select alternate positions, displacement routes, and establish a signal should movement be unavoidable. Brief key personnel.

b. The platoon leader instructed to displace upon receiving fire has a different list in mind. For example, prior to receiving incoming fire:

(1) Camouflage.

(2) Prepare limited protection for personnel/equipment.

(3) Reconnoiter/select alternate positions, displacement routes, and march order signal.

(4) Prepare alternate positions.

(5) Prepare defensive positions.

(6) Improve individual protection.

(7) Improve equipment protection.

Section II. ORGANIZATION OF THE DEFENSE

4-3. GENERAL

The primary consideration in organizing the defense is to provide early warning and defense in depth. To aid the discussion which follows, fig 4-1 depicts the areas of influence and interest for the Pershing battery/platoon and its supporting infantry.

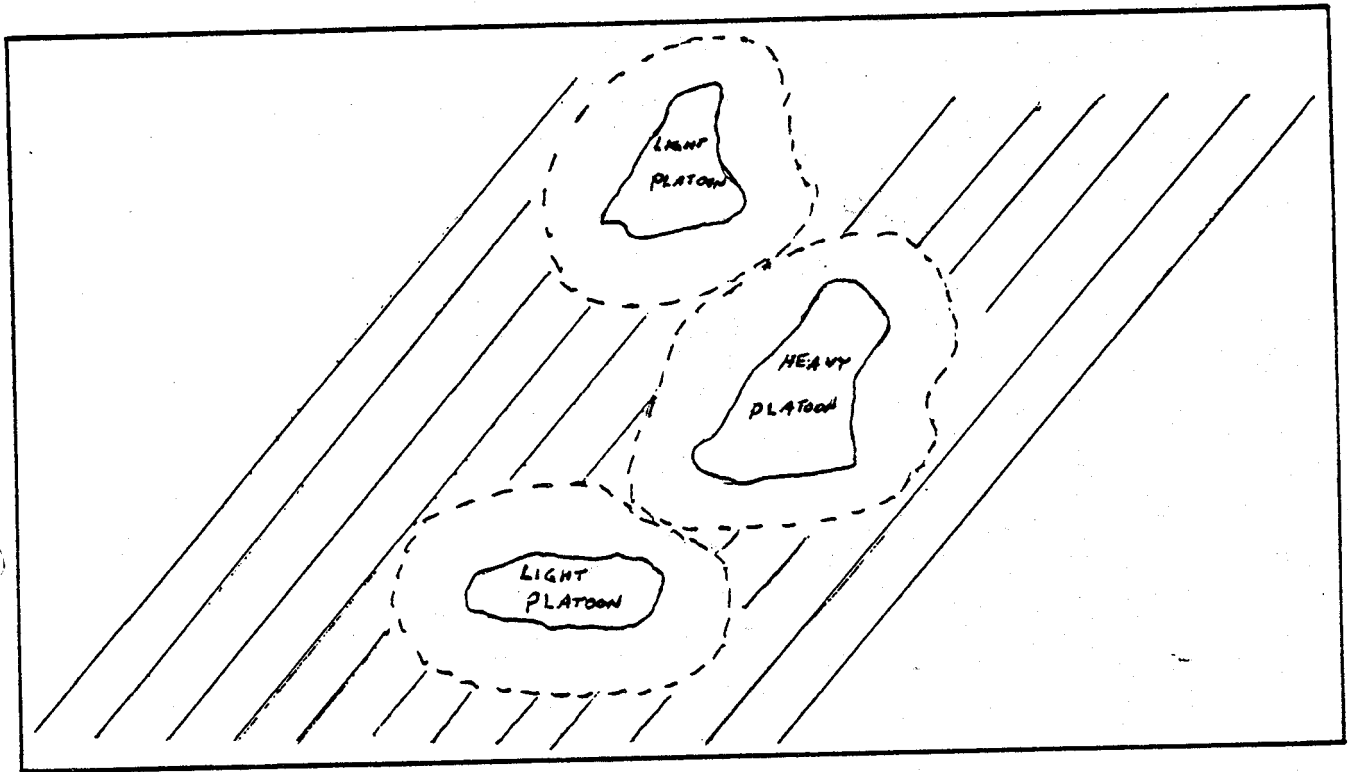



- LEGEND:
-  = Firing platoon perimeter: delineates FA area of influence.
 -  = 5 km out from perimeter: delineates FA area of interest; infantry area of influence.
 -  = Area further than 5 km out from perimeter: delineates infantry area of interest.

Figure 4-1. Areas of influence/interest.

The defense is further organized to include coordination between units, patrols, LP/OP, remote sensors, the platoon perimeter, the defense control center, and the reaction force.

4-4. COORDINATION

The dispersion of Pershing II units on the battlefield allows one unit to provide early warning to another unit. Coordination must ensure rapid transmission of information pertaining to Threat activities to all affected units. A spot report using the SALUTE format is an effective means of sending this kind of information.

SALUTE FORMAT

Size.....How many individuals can be seen?
Activity.....What are they doing?
Location.....Where are they? Give grid coordinates if possible.
Unit.....What is their unit? What are the distinctive markings on their uniforms?
Time.....What time was the sighting made?
Equipment....What equipment can you see?

4-5. PATROLS

Patrols can effectively provide early warning and engage a small enemy element some distance from the unit's position. These patrols may be either mounted or dismounted and should be sent out from the position on an irregular time schedule (if the unit is in a hide position, mounted patrols will not be used). The DCC must be aware at all times of the positions and routes of patrols to avoid their coming under fire from the perimeter.

4-6. LISTENING/OBSERVATION POSTS

The LPs and OPs should be placed to ensure that a Threat force is identified long before it could pose a threat to the position. Coverage must ensure 360° protection during daylight and darkness, the use of night vision devices will aid in this effort. Communications must be maintained between LPs/OPs and the DCC.

4-7. REMOTE SENSORS

As time allows, remote sensors are emplaced beyond the limits of the perimeter. Areas likely to be used by the enemy and that are not easily observable by LPs/OPs or patrols are likely areas for sensor emplacements.

4-8. DEFENSIVE PERIMETER

Defensive fighting positions should be chosen to add depth to the defense of the unit's position and to afford intervisibility between fighting positions. The patrols, LPs/OPs, and sensors form the outermost ring of defense. The defensive perimeter must stop the small, squad-sized enemy force from successful penetration during the day or night. As time permits, perimeter positions should be dug in (guidance on preparing fighting positions is contained in FM 7-7). By using the night vision devices, the ability to see the enemy is maintained during the hours of darkness. Although not all perimeter positions need to be continually manned, they must all be designated and improved. The

perimeter will be divided into quadrants with an NCOIC assigned for each quadrant. One position, usually on a major avenue of approach, within each quadrant is manned at all times.

a. Range cards. Each weapon on the perimeter must have a range card. The range card permits the placement of fires on designated targets during periods of limited visibility. It helps in a relief in place by giving the relieving gunner all the information he needs to respond immediately to enemy action. It also provides information to the senior infantryman, 1SG, and platoon leader for inclusion in their fire planning. Appendix B provides guidance on preparing a range card.

b. Defense diagram. After terrain sketches and range cards are prepared by the individual soldiers on the perimeter, the senior infantryman compiles them into a defensive diagram and presents them to the platoon leader. The firing platoon leader checks the defense diagram for completeness and ensures that the platoon position is adequately defended. Appendix C provides guidance on preparing a defense diagram.

4-9. DEFENSE CONTROL CENTER

Within each heavy and light position, a Defense Control Center (DCC) is established and maintained by the senior infantryman, the firing platoon sergeant, or the battery first sergeant. The DCC is located near the PCC/BCC and serves as the entry control point to the restricted area surrounding the PCC/BCC. A switchboard in the DCC provides communications with the PCC/BCC, exclusion area gate (X-Gate), listening posts, observation posts, and each perimeter position. All matters concerning the defense of the position are coordinated through the DCC.

4-10. THE REACTION FORCE

Should the platoon position be attacked or penetrated by enemy forces, the reaction force will respond as directed by the DCC. The reaction force should be made up of at least a squad-type element and should be organized as follows:

- a. Reaction force NCO in charge--platoon sergeant or chief of section.
- b. One man per firing crew.
- c. One man from the PCC/BCC.
- d. One man from the communications element.
- e. One man from the maintenance element.
- f. One man from the mess element.

Figure 4-2 shows how the position might look with all of its defenses.

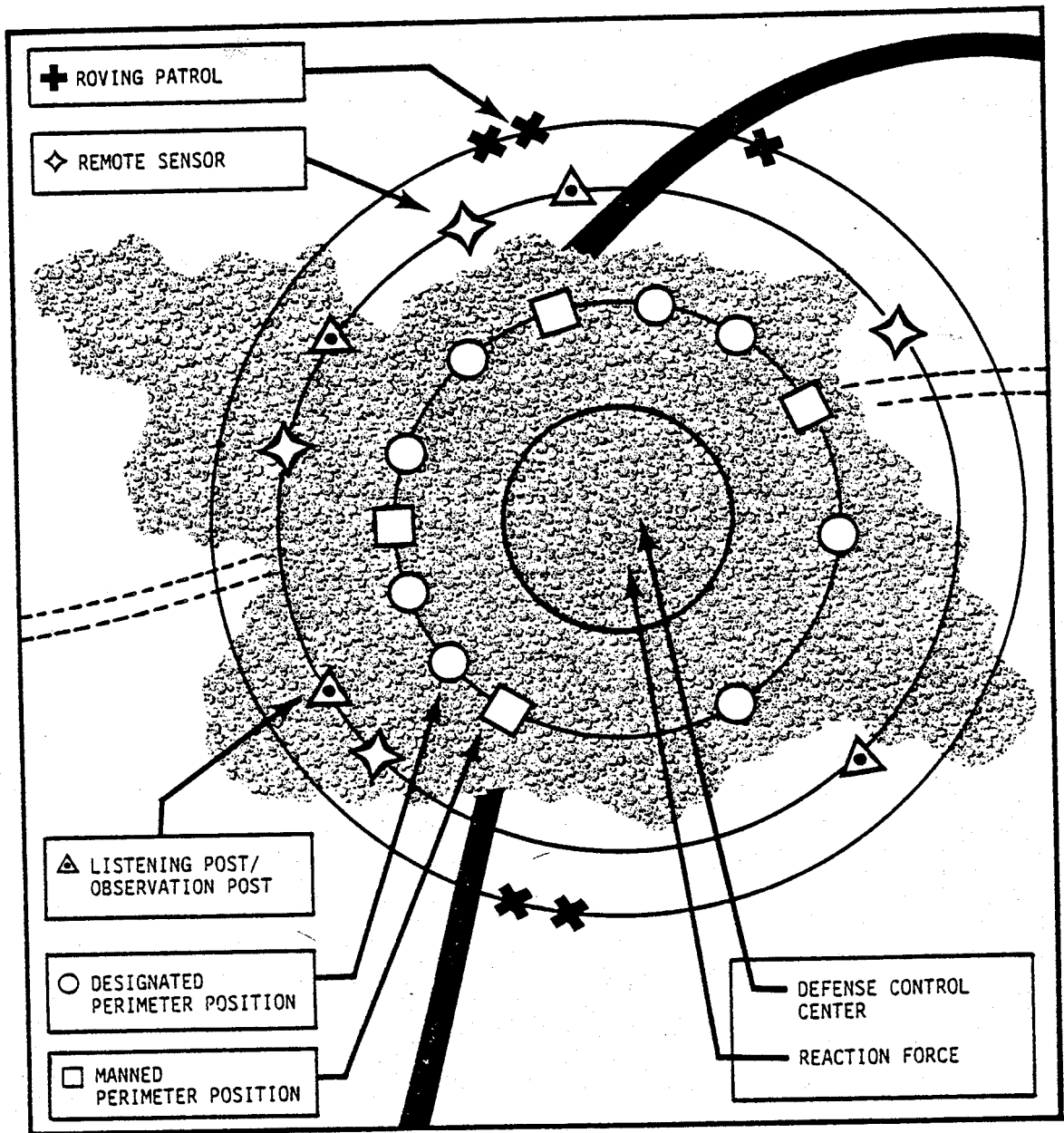

Figure 4-2. Example of a Pershing platoon's defense.

Section III. CONDUCT OF THE DEFENSE

4-11. DEFENSE AGAINST DETECTION

The most effective means of defending a unit position is to prevent the Threat from detecting and locating the position. Detection is accomplished through the study of doctrine and the battlefield printing of signal intelligence, imagery intelligence, and human intelligence. Passive defense measures can greatly enhance survivability.

a. Avoid visual detection. Pershing II units must make every effort to avoid visual detection from the ground and the air.

(1) Move at night. Whenever possible, vehicle movements should be made at night or during other periods of limited visibility to preclude easy identification of equipment types. Night convoys are harder to follow and identify. When advance party operations take place during daylight, the party must prevent identification and conceal any Pershing signature.

(2) Site equipment. Position equipment to make maximum use of available natural camouflage. Natural foliage can effectively hide Pershing II units. Positions with deciduous vegetation should not be selected during the winter. Urban areas may provide excellent concealment and cover.

(3) Construct camouflage. The camouflaging effect of natural foliage is augmented by erection of lightweight radar-scattering screening systems over equipment. The object is to break the outline of the equipment. Straight, horizontal lines, such as the top of a PCC or a missile, are not natural in a forest and will stand out. The entire piece of equipment must be covered, with particular attention to reflective surfaces such as windshields and mirrors. Individual fighting positions, such as those on the perimeter, are camouflaged in much the same manner as are vehicles and other pieces of equipment. Camouflage must provide concealment from above as well as from the sides to protect against air and ground observation.

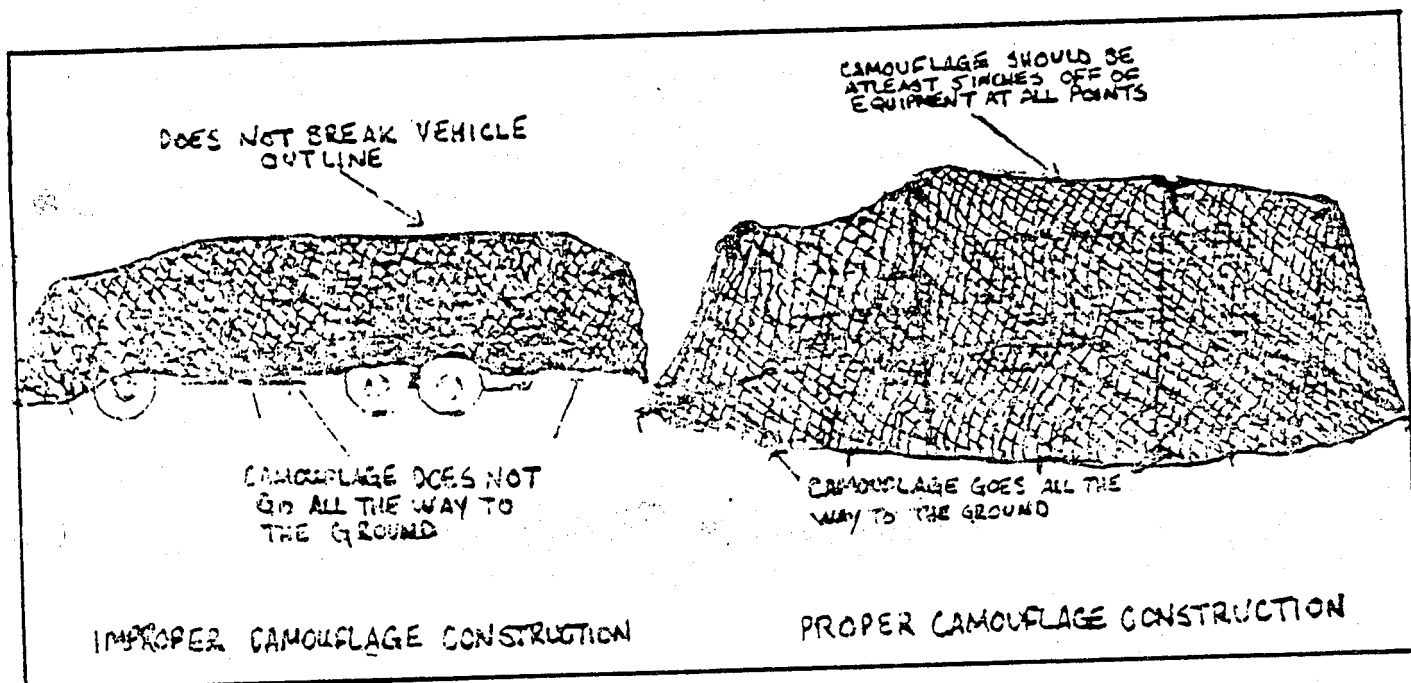

Figure 4-3. Camouflage.

(4) Enforce light and noise discipline. Perfect camouflage will not prevent detection unless good light and noise discipline is observed and continuously enforced. Light leaking from a tent or opened doors of lighted shelters during hours of darkness will expose a unit's position. Noise discipline is very important, especially during the hours of darkness.

b. Avoid electronic detection. Pershing II units require multiple communications means with higher headquarters in a nuclear or nonnuclear environment. Radio transmissions must be minimized. Positioning of units must support defensive communications measures in order to minimize the possibility of Threat forces locating and identifying Pershing II units through the use of radio intercept and direction-finding techniques.

(1) Positioning of units. Positioning units parallel, rather than perpendicular, to the FLOT and using directional antennas can help make RDF attempts ineffective. Directing radio signals parallel to the FLOT minimizes those signals that reach Threat forces.

(2) Equipment siting. Emplacing an antenna so that a hill mass, a group of trees, or a building lies between it and the Threat serves to mask transmissions. The intervening objects either absorb or reflect the radio waves and prevents them from reaching the Threat.

(3) Directional antennas. Directional antennas will be used whenever possible. Transmit only to those people who need to get the information, not to the enemy.

(4) Low power. Radio sets should be used on the lowest possible output power settings. Since FM radios have a shorter operating range, they should be used rather than AM radios when possible.

(5) Secure transmissions. All radio operators must be trained to ensure that sensitive or classified information is not transmitted over nonsecure means. Classified information or any essential element of friendly information must be encoded or transmitted over a secure means to deny this information to the enemy.

(6) Short transmissions. Radio transmissions in excess of ten seconds are highly susceptible to intercept and radio direction finding (RDF). Transmissions of 20-25 second duration allow for intercept within ten seconds, direction finding of the transmitter, and the targeting sequence to begin within 20-25 seconds. The targeting sequence can continue even if friendly transmissions cease. Radio operators should be trained to write out messages before keying a microphone and to use frequent breaks in long transmissions.

(7) Wire. If the battery's platoon positions are close enough, wire should be layed between PCCs and the BCC. By using wireline adapters, this is a secure means of communications.

(8) Couriers. Couriers should be used to send routine, recurring reports and whenever else possible. Messages may be sent to higher or lower headquarters during routine administrative trips such as those for mess, fuel, and repair parts resupply. Vehicle movement should, as noted before, occur during periods of limited visibility and be kept to a minimum. The location of units must be concealed.

4-12. DEFENSE AGAINST AIRBORNE ATTACK

Threat airborne forces are targeted specifically against Pershing II. The great mobility of Pershing II units permits movement to avoid engagement with large ground forces if early warning is ensured. A key defense against airborne forces is to avoid being located. Pershing II units threatened by airborne attack should be moved. Engagement should be undertaken only as a last resort to facilitate withdrawal. Augmentation from rear area forces will be required to neutralize airborne forces.

4-13. DEFENSE AGAINST AIR ATTACK

Pershing II units will face, and must be able to defend against, a significant air threat. The best defenses against air attack are to avoid being located by ground based forces/agents and to avoid being seen from the air. If air defense assets are not available, equipment

and personnel should be dispersed to minimize damage from strafing or bombing attacks. If attacked, all organic weapons must be employed in accordance with FM 44-8 and FM 21-2. Accuracy is not as important as massed fires. Air defense weapons should be positioned to make best use of their range capabilities.

4-14. DEFENSE AGAINST MISSILE/ROCKET ATTACK

Missiles or rockets will be employed against Pershing II units that are accurately located by ground or air forces. Units should be well dug in and trained to respond to nuclear and chemical attacks. Commanders should make every effort to deny information about position locations to the enemy.

4-15. DEFENSE AGAINST NUCLEAR, BIOLOGICAL, AND CHEMICAL WARFARE

There is a very real chance that the enemy will use nuclear, biological, and chemical (NBC) weapons in future conflicts. A detailed discussion of NBC defense is in appendix D and FM 3-5.

CHAPTER 5
PHYSICAL SECURITY IN NUCLEAR OPERATIONS

Because of the political sensitivity and massive destructive potential of nuclear weapons, physical security for those weapons must be effective. All Pershing II units must be able to provide effective physical security for nuclear weapons in their custody. Physical security of nuclear weapons involves such things as:

- Selecting only qualified and reliable individuals to work in nuclear operations.
- Controlling the release (launch) of nuclear weapons.
- Providing for the security of nuclear weapons in convoy.
- Safeguarding nuclear weapons at the position area.
- Destruction of equipment to prevent enemy use.

Although every individual in a unit is not assigned as a launcher crewman or custodial agent, all members of the unit must be trained to support the mission of physical security. The most junior member of a unit could play a significant role in providing security for a nuclear weapon.

5-1. PERSONNEL RELIABILITY PROGRAM

a. AR 50-5 establishes the Personnel Reliability Program (PRP) as a safeguard to ensure that only qualified and reliable individuals are allowed to work in nuclear operations.

b. Personnel will be neither assigned to nor trained for assignment to a nuclear duty position until they are screened in accordance with AR 50-5 and found qualified. While in a nuclear duty position, individuals will be screened periodically to ensure that they continue to satisfy the requirements of the program.

c. It is the responsibility of the BC to ensure that only PRP qualified individuals are allowed to participate in nuclear operations.

d. There are two types of nuclear duty positions: controlled and critical. AR 50-5 contains a detailed explanation of each.

e. In a combat environment the provisions of AR 50-5 are modified by FM 100-50. For example, the commander may waive administrative procedures of the PRP in combat including the Nuclear Duty Position Roster, but he must take whatever actions are necessary, consistent with good judgement, to fulfill his mission responsibilities with available manpower resources.

5-2. CONTROLS ON NUCLEAR RELEASE

a. Stringent controls are placed on the handling of nuclear weapons to avoid inadvertent arming and/or launch. These control measures are exercised by the National Command Authority (NCA) and the Joint Chiefs of Staff (JCS). These measures involve the use of sealed authentication systems (SAS) and permissive action links (PAL). The policies and procedures for safeguarding and using SAS and PAL are specified in JCS Pub 13 (S).

b. The permissive action link is a device that interrupts the firing sequence until secure enabling information is received. Procedures must be established to ensure that PAL devices are properly secured in accordance with JCS Pub 13 Volume II (S).

c. The SAS material is used to authenticate certain nuclear control orders. It must be maintained under two-man control at all times. Procedures involved with SAS material may be referenced in JCS Pub 13, Volume I (S).

5-3. CUSTODIAL AGENTS

The custodial agents are the direct representatives of the custodian (the last individual who has signed for the nuclear weapon). Custodial agents are tasked with--maintaining the exclusion area, enforcing the two-man rule, and providing security for the mission vehicle. The training and supervision of custodial agents are command responsibilities from the battery commander down to the first-line supervisor. Custodial agents must be trained in the following areas:

a. General knowledge. All custodial agents must be familiar with the general knowledge required of soldiers in their grade such as NBC defense and weapons characteristics. They must thoroughly understand the following concepts:

(1) Two-man rule. A minimum of two authorized persons--each capable of detecting incorrect or unauthorized procedures with respect to the task being performed and each familiar with applicable safety and security requirements--must be present during any operation that affords access to material requiring two-man control. Each custodial agent should know when the two-man rule is in effect and the procedures for enforcing it.

(2) Deadly force. Each custodial agent must know the five circumstances under which the use of deadly force may be authorized. They are as follows:

(a) In self-defense, or in defense of another member of the security force, when bodily injury or death is imminent.

(b) When necessary to apprehend unauthorized individuals in the vicinity of nuclear weapons or nuclear components.

(c) When necessary to prevent unauthorized access, arson, theft or sabotage of nuclear weapons or nuclear components.

(d) When necessary to prevent the escape of an individual believed to have committed one of the above acts.

(e) When authorized by a superior because of the occurrence of one of the above acts.

(3) Fire-fighting procedures. Each custodial agent must be able to use the fire-fighting techniques for the PII system. He must be able to demonstrate knowledge of circumstances that would cause him to abandon his attempts to fight the fire. Information on fighting a fire involving a nuclear weapon is contained in TB 385-2.

b. Knowledge of the Threat. Every custodial agent must be able to discuss the potential Threat to the security of the weapons, to include--size, tactics, weapons, and means to counter that Threat

c. Security assets. Each custodial agent must be able to describe the security resources that are immediately available to him and those that are on call in case of a security incident. He must know the following:

(1) The type and amount of ammunition available.

(2) The location of the ammunition.

(3) The types of reaction forces and the forces that reinforce them.

(4) The local security devices (to include intrusion detection alarms, remote sensors, and communications nets as applicable).

d. Destruction to prevent enemy use. Each custodial agent must know the procedures for destroying his unit's equipment to prevent its use by the enemy. Training should focus on the ability of custodial agents to perform destruction without supervision if necessary, and in the order of priority as determined by the commander based on international agreements.

e. Convoy operation requirements. Custodial agents are trained in all aspects of custody, to include the responsibilities of the courier officer. If for any reason the courier officer no longer can perform his duties, the custodial agents, as designated in the custodial chain of command, will assume the duties of courier officer. If the convoy halts, the courier officer is responsible for maintaining an exclusion area.

5-4. EXCLUSION AREA

a. Nuclear safety rules must be observed while nuclear weapons are maintained in open storage. Whenever a platoon has custody of nuclear weapons, it will establish an exclusion area around those weapons. The primary purpose of the exclusion area is to preclude unauthorized or uncontrolled access to nuclear weapons. When establishing the exclusion area, every effort will be made to provide a safe and secure environment for the weapons while concealing the nature and purpose of the activity. Immediately upon entering an area, guards will dismount from within the convoy and act as a moving exclusion area to prevent unauthorized access to the weapons. Within the defensive perimeter, the exclusion area may range in size from a single missile on an erector-launcher to a basic load of warheads for an entire battery.

b. Minimal requirements for establishment of an exclusion area are addressed in FM 100-50. More stringent requirements for exclusion area establishment (e.g., marking a barrier with specific material) may be addressed through local policy.

c. A single entrance to the exclusion area will be designated. This entrance will be controlled by two PRP-qualified guards, who will allow entry only to authorized personnel.

(1) Authorized personnel are those designated on a nuclear duty position roster (NDPR). A current NDPR will be available to the gate guards.

(2) Recognition by the PRP-qualified gate guards is sufficient to allow authorized personnel entry into the exclusion area.

(3) The site commander or his designated representative may verbally authorize entry for other personnel.

d. The number of personnel inside the exclusion area will be accounted for.

e. Field phone communications from the exclusion area to either the DCC or BCC/PCC should be maintained at all times.

f. Within the exclusion area a limited access area will be established around each weapon system. This limited access area will extend one meter out from the erector launcher in all directions, as depicted in figure 5-1. Entry to this area should be granted only when operations are required in the area. At no time will an individual be permitted to be alone in the limited access area. All operations in the area will be performed in strict compliance with the two-man rule.

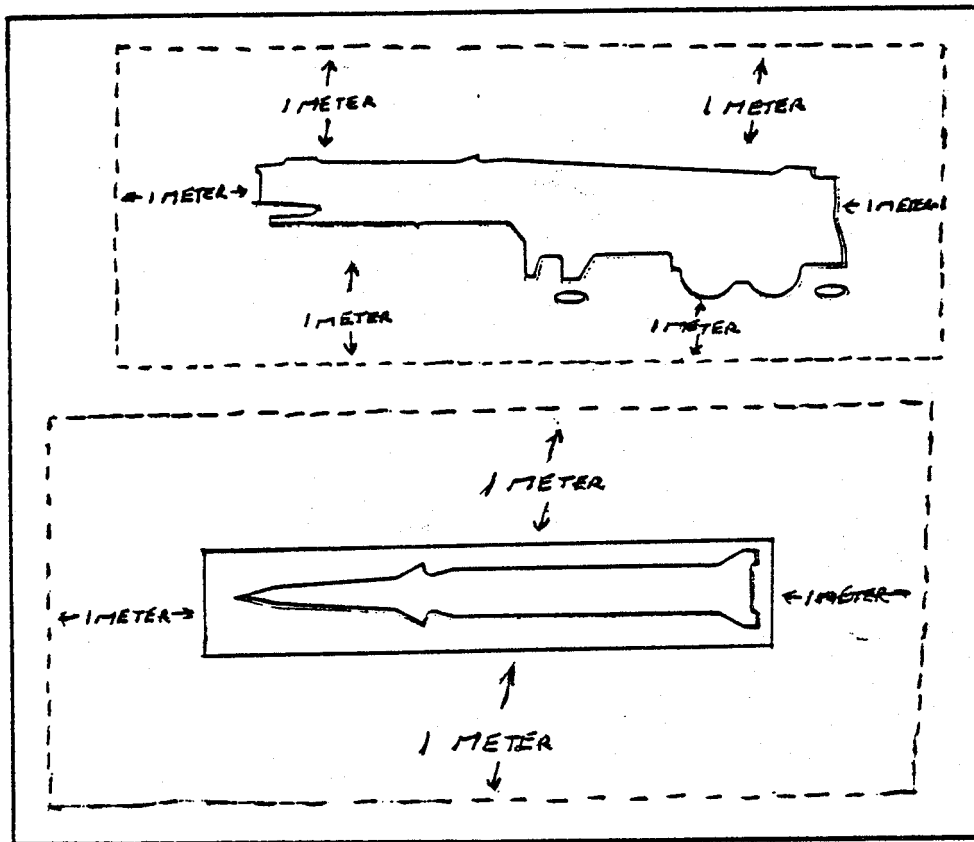

Figure 5-1. Limited access area.

g. The area outside the exclusion area also must be secured in accordance with Chapter 4. This is to preclude unauthorized access to nuclear weapons by preventing unauthorized personnel access to the exclusion area.

5-5. DUTIES OF KEY PERSONNEL IN THE NUCLEAR CONVOY

Policies and procedures for the logistical movement of nuclear weapons are discussed in AR 50-5. A nuclear convoy transports the weapon from its current location to an alternate storage location or to a firing point. Security and custody of a nuclear weapon is more stringent than for a convoy of conventional ammunition. Duties of the key personnel involved in a convoy are discussed below.

a. Convoy commander. Normally, the convoy commander is a commissioned officer who has been tasked to--

- (1) Ensure security for the convoy is provided.
- (2) Provide route security.

(3) Provide, in coordination with the courier officer, sufficient vehicles and associated equipment for the operation.

(4) Ensure drivers and assistant drivers of mission vehicles (those vehicles carrying a nuclear load) have the appropriate clearance for nuclear operations and are in the PRP.

(5) Provide and maintain radio communications with each vehicle in the convoy. In addition, communications will be maintained with elements outside the convoy itself (i.e., higher headquarters and additional security forces).

b. Courier officers. The courier officer is the direct representative of the accountable officer or custodian. He has the final authority concerning the security, custody, and destruction to prevent enemy use of the weapon. Normally, he is tasked as follows:

(1) Define the exclusion area. The size of the exclusion area for the convoy is at the courier officer's discretion but will never be less than the mission vehicle (to include the cab portion).

(2) Inspect all vehicles and equipment involved directly in the transport of the weapon to ensure they are secure and safe.

(3) Provide the material and trained personnel to perform destruction to prevent enemy use during the operation should it become necessary.

(4) Inspect all tie-downs, blocking, and bracing for the weapon.

(5) Brief all personnel. The courier officer's briefing will include, as a minimum--

(a) Custodial chain of command.

(b) Purpose (mission) of the convoy.

(c) Route of the convoy (to include alternate routes).

(d) Emergency actions (destruction, fire-fighting, ambush, air attack).

(e) Convoy communications procedures.

(f) Security requirements.

(6) Maintain the equipment necessary to receive, transmit, and authenticate nuclear control orders.

c. Convoy NCOIC. The convoy NCOIC is the courier officer's enlisted assistant. Normally, he is tasked to--

- (1) Directly supervise the custodial agents.
- (2) Act as the assistant driver of the mission vehicle or the lead mission vehicle in a multiple vehicle convoy.
- (3) Act as the courier officer in case of incapacitation or death of the courier officer.
- (4) Perform duties as assigned by the courier officer.

d. Security force commander. Normally, the security force commander is an officer or NCO tasked with training, equipping, and organizing the convoy security forces with the exception of the custodial agents. If personnel assets are limited, the security force commander position may be filled by the convoy commander.

5-6. CONVOY ORGANIZATION

a. Nuclear convoy organization depends mostly on the tactical situation and the desires of the courier officer. Minimum requirements are contained in FM 100-50. For planning purposes, nuclear convoy organization must provide for command and control of the convoy, buffer vehicles between mission vehicles, the security force, and a recovery capability.

b. Minimum personnel requirements for nuclear convoys are specified in AR 50-5 and local policies.

c. Adequate communications must exist within the convoy. Normally, FM radios are used to control the convoy, and at least one alternate means must be designated for communication with the controlling headquarters. For example, commercial telephone or AM radio could be used as the alternate means.

d. Test equipment will be carried to verify serviceability of the warhead when it is received from the consignor. This prevents transporting and delivering an unserviceable weapon.

5-7. CONVOY SAFETY AND SECURITY

Although the convoy organization depends on the tactical situation, particular emphasis is placed on security and safety. Movement procedures discussed in chapter 3 apply to the nuclear convoy with the following additional considerations.

a. All vehicles must be free of electrical or mechanical defects that could prevent safe arrival as determined through proper preventive maintenance checks and services (PMCS).

b. Authorized fire fighting equipment must be accessible during movement.

c. No maintenance or repairs that might increase the chance of fire will be performed on a vehicle while a nuclear weapon is on board.

d. Excessive handling of nuclear weapons during movement operations will be avoided. Weapons and containers must not be dropped, bumped, or marred.

e. Before movement, all vehicles must be searched and inspected for unauthorized personnel, equipment, and sabotage.

f. An exclusion area must be established around the load-carrying vehicle whenever it is stopped, parked or being loaded or off-loaded.

g. During any movement, communications must be maintained with a headquarters that can respond to a request for assistance.

h. Signals should be developed to ensure personnel are aware of emergency situations as soon as they develop.

5-8. AIR MOVEMENT

a. Nuclear weapons may be moved by air. During air movement, minimum security measures include a courier officer and two PRP-qualified guards for each load-carrying aircraft. The number of different aircrews, couriers, and guards involved in nuclear airlift operations will be kept to the minimum necessary for effective movement.

b. Times, flight plans, and destinations will be handled on a strict need-to-know basis and will be appropriately classified.

c. Aircrews must be screened in accordance with AR 50-5.

d. Specific procedures for air movement of nuclear weapons are in FM 100-50. Detailed information on conducting an airlift is in FM 55-12.

5-9. COURIER OFFICER CHECKLIST

The following checklist is provided to help the courier officer perform his duties.

CHECKLIST FOR COURIER OFFICERS

Note. This checklist is provided as a guide only. Other items as directed by higher headquarters or as determined by the courier should be added.

1. Before departure.

- Security personnel issued travel orders (if required).
- Billeting, messing, and return transportation arranged.
- Security personnel properly equipped.
- Security personnel checked for appropriate security and reliability clearances.
- Escort personnel briefed.
- Strip map with primary and alternate routes provided to drivers. Map includes checkpoints; contact points for military, state, and local authorities; and authorized stops.
- Administrative documents obtained.
- COMSEC material obtained.
- Escort vehicles inspected (as required).
- Communications check made.
- Chain of command designated.
- Appropriate directives on transportation, safety, fire-fighting, and security obtained.
- Security personnel briefed on location of extra ammunition, fire fighting equipment, and route of march.
- Guard and transport personnel properly armed and equipped.
- Transportation equipment inspected by consignee.
- Security personnel briefed by consignee.
- Tie down straps inspected.
- Materiel loaded and blocked.

- Materiel signed for.
 - Driver or aircrew issued instructions (DD Form 836 or 1387-2 [Special Instructions for Motor Vehicle Drivers]).
 - Bill of lading and shipping documents obtained.
 - Authorized recipient identified.
 - Convoy formed.
 - Departure time reported.
2. En route.
- Convoy discipline maintained.
 - One guard, in addition to the driver, present in cab of commercial or military carrier.
 - Two-man concept in force at all times.
 - Reports of progress submitted to appropriate headquarters.
3. At destination point.
- Arrival reported.
 - Authorized recipient identified.
 - Vehicles inspected by authorized recipient.
 - Equipment unloaded under adequate security.
 - Receipt for materiel signed by recipient.
 - Billeting, messing, and return transportation arranged.

5-10. DESTRUCTION TO PREVENT ENEMY USE

Destruction to prevent enemy use is authorized in accordance with national and theater policies. The final responsibility for conducting these operations on nuclear weapons, associated documents, and test and handling equipment lies with the highest ranking, on-the-scene, individual in the US custodial agent chain of command. Commanders must clearly establish procedures, responsibilities of personnel, training programs, and priorities for conducting these operations.

CHAPTER 6 DETERMINATION OF LOCATION

The Pershing II terminal guidance system is functional when a reference scene of the target area is provided. The Pershing II missile may also be fired using only inertial guidance if reference scenes are not available. However, accuracy of the system will be degraded. For the inertial guidance system to be effective, the determined launch location must be within a horizontal accuracy of 50 meters of the actual terrain location. Normally, the individual launch points are determined by the Position and Azimuth Determining System (PADS) team. The battalion has two PADS teams, each consisting of two personnel. The PADS operator, a chief of survey party, and the driver/radio operator have a thorough knowledge of field artillery survey. Each PADS team has a ½-ton vehicle to house and transport the PADS equipment. The PADS crews are under operational control of the battalion headquarters. They respond to battery and platoon needs on a mission-by-mission basis.

If PADS is not available, the platoon center must be established by using traditional survey techniques. If launch points are not surveyed, proper pacing techniques and computation of pace data must be performed to derive each launcher location. All key personnel within the battery should be able to accurately transfer survey control by pacing (see paragraph 6-4 below).

6-1. LAUNCH POINT DETERMINATION BY PADS

a. The PADS may be used in one of two ways to survey firing platoon positions: each launch point may be located by PADS or the platoon center only may be located. With either method, each launch point must be located within a horizontal accuracy of 50 meters.

(1) If PADS is used to locate individual launch points, pace data cards are not needed. Before occupation, PADS will locate the launch points designated by the advance party.

(2) If PADS is used to locate the Platoon Center (PC) only, the location of each launch point must be determined by pacing.

b. The following limitations should be considered when using PADS:

(1) The PADS must warm up for 30 to 45 minutes before initialization for a survey mission.

(2) The PADS must up date over a survey control point (SCP) before beginning a survey mission.

(3) Each survey must be completed by closing on an SCP within a 55-km radius of the start SCP.

(4) Each survey must be completed within 5 hours to avoid inaccuracies.

(5) While surveying, PADS must stop at least once every 10 minutes for conduct of a zero velocity correction.

c. Detailed information on PADS equipment and operations is in FM 6-2 and TM 5-6675-308-12.

Note. The PADS can be mounted in a helicopter to speed the survey process.

6-2. SURVEY DATA CARD

Because of operational requirements, the PADS crew may not be available after launch points have been determined by the platoon. Therefore, battalion headquarters operates a Survey Information Center (SIC). The SIC maintains survey information on DA Form 5075-R (Artillery Survey Control Point) for each predesignated position within the battalion area of operation. As necessary, the SIC gives copies of the appropriate 5075-R to the batteries. Contents of the card gives the platoon leader vital information from which launcher locations can be derived. The 5075-R should contain the following information.

a. Survey control point.

- (1) STATION NAME. The name of the station for which the information is provided.
- (2) ESTABLISHED BY. The battalion to which the PADS team belongs.
- (3) COUNTRY. Self-explanatory.
- (4) GRID & ZONE. Extracted from a Universal Transverse Merlator (UTM) map.
- (5) MAP SHEET NO. The number of the appropriate 1:50,000-scale military map.
- (6) DATE. The date the survey card is completed.
- (7) LOCALE. The town closest to the location.
- (8) EASTING, NORTHING. The UTM coordinates of the platoon center. See paragraph 6-4 on UTM coordinates.
- (9) HEIGHT. Altitude of the platoon center in meters or feet (must specify).

b. Azimuth marks. It should be specified whether the distance from the end of the orienting line (EOL) to the platoon center has been measured, estimated, or computed.

c. Sketch. The sketch should be as close as possible to scale and should include the platoon center, the EOL, and any prominent terrain features.

d. SCP description. The SCP description must include a sufficient description of the platoon center that someone who has not previously been in the area can recognize it. Also included are a description of the EOL and the distance from the PC to the EOL. The description may be continued on the reverse side of the form if necessary.

ARTILLERY SURVEY CONTROL POINT				ANNEX A TO STANAG 2885	
For use of this form, see FM 6-2; the proponent agency is TRADOC					
UTM ZONE	UTM SQUARE	STATION NAME		ACCURACY	
		STATION NUMBER		E + N	
		MAP SERIES SHEET NO		AZIMUTH	
HOW MARKED		E	N	ALTITUDE	
		LONGITUDE	LATITUDE		
NOTES		N ↑ LOCATION DIAGRAM			
WARNING: THERE ARE TWO DIFFERENT WAYS OF WRITING THE NUMBERS 1, 7 AND 1-7					

DA FORM 5075-R (MAR 82)

Figure 6-1. DA Form 5075-R.

6-3. COORDINATES

a. The coordinates used by the PADS team are the complete UTM coordinates that reference the point within the entire grid zone. The easting of the point indicates the number of meters east (or west) the point is from the grid zone's central meridian. The northing of the point is the number of meters that point is north (or south) of the equator (a false northing is used in the Southern Hemisphere). These coordinates can be found on the map sheet by referencing the small numbers in the lower left-hand margin. However, there is generally no requirement to use the complete coordinates within the firing battery.

b. An example of the coordinates of a surveyed platoon center follows:

	EASTING	NORTHING
3d Plt, Btry B Center	638275.4	5456575.2

To convert this to missile data, round both the easting and northing to the nearest meter and extract the first five digits to the left of the decimal in both numbers. The grid should read 38275 (easting) 56575 (northing). The platoon leader can then plot this grid as platoon center. For further information on the derivation and structure of the UTM grid system, see FM 21-26.

6-4. PACE CARDS

Pacing is used to determine coordinates of launch points when they are not surveyed. A surveyed point (normally the PC) is required for pacing. The surveyed point must be not further than 500 meters from the launch point for which pacing data will be obtained. When absolutely necessary, pace data may be derived from a prominent terrain feature such as a road intersection with the grid read from a map. As a class B, 1:50,000 map is only accurate to within 50 meters horizontally, this is a LAST RESORT.

a. Construction. Using the 5075-R provided by the SIC, locate the platoon center or surveyed point. Using a compass, orient in a cardinal direction (north, south, east, or west) toward the location of the platoon's missiles. The distance is measured from the PC along the cardinal direction to a point perpendicular to the launch point of the erector-launcher. From this position, the distance to the base of the round is measured. Measurements may be taken by pacing or by using a steel tape. The accurate measurement of one's pace count, or the number of paces per 100 meters, must be obtained (fig 6-2).

b. Example. In figure 6-2, locate the platoon center and, using a compass, orient toward south. Use a factor of 0.9 (111 paces per 100 meters) to convert paces to meters. Pace 25 meters to the south, stop, make a right face, and pace 12 meters to the west. This is the location

of missile 1. Record the measurements and repeat the procedure for missiles 2 and 3. Diagram the relative positions of the missiles on a piece of paper and add or subtract the measurements to determine the easting and northing of each missile. The derived UTM coordinates are used as manual data entries for each missile.

c. Double check. To avoid erroneous data being programed into the system, two qualified personnel should make independent computations and both sets of data should be checked.

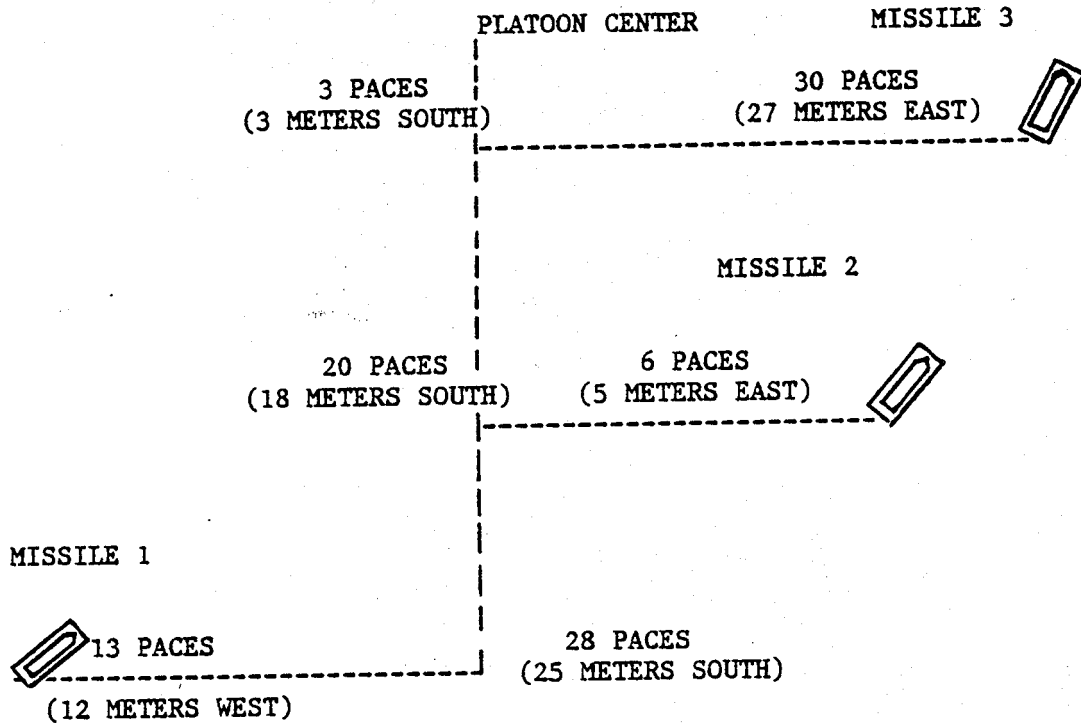

100

NUMBER OF PACES PER

METERS = 111 PACING
 FACTOR = $\frac{100}{111} = 0.9$

MISSILE 1		MISSILE 2		MISSILE 3	
EASTING	NORTHING	EASTING	NORTHING	EASTING	NORTHING
638275	5456575	638275	5456575	638275	5456575
W(-) 12	S(-) 25	E(+) 5	S(-) 18	E(+) 27	S(-) 3
<u>638263</u>	<u>5456550</u>	<u>638280</u>	<u>5456557</u>	<u>638302</u>	<u>5456572</u>
MDE04	MDE05	MDE04	MDE05	MDE04	MDE05

EAST (+) NORTH (+)
 WEST (-) SOUTH (-)

Figure 6-2. Example pace card.

6-5. THE M-2 COMPASS

The M-2 compass is the primary instrument for determining pace data to a launch point. The unmounted magnetic compass is a multipurpose instrument used to obtain angle of site and azimuth readings. See figure 6-3.

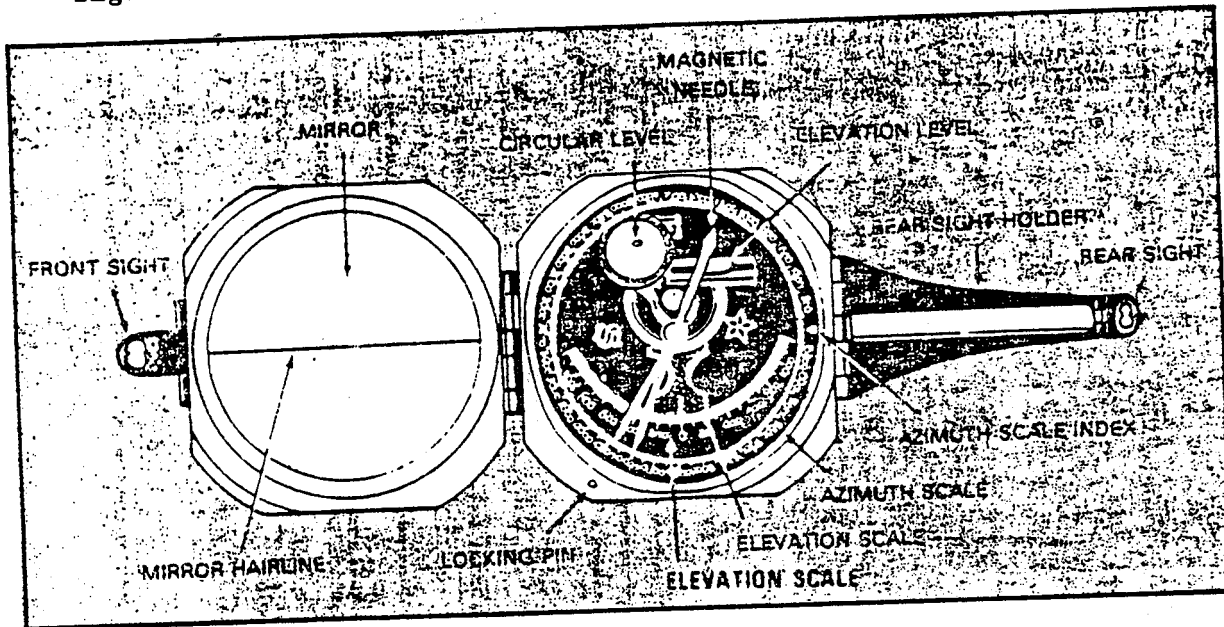

Figure 6-3. M-2 compass, top view.

a. Components.

(1) Azimuth scale. The azimuth scale is numbered every 200 mils from 0-6400, graduated every 20 mils, and can be read to an accuracy of 10 mils.

(2) Sights. The compass employs front and rear leaf sights and a mirror in the cover for sighting and reading angles.

(3) Levels. The compass is equipped with a circular level for leveling the instrument before reading azimuth values. A tubular level is used with the elevation scale to measure angles of site.

(4) Angle of site mechanism. Rotation of the level lever causes the elevation level and elevation scale index to rotate as a unit. The index clamps against the bottom piece to prevent the mechanism from moving unless actuated by the level lever. This mechanism is rarely, if ever, used in a Pershing unit.

(5) Magnetic needle and lifting mechanism. The magnetic needle provides a magnetic north direction for orienting purposes. The needle is delicately balanced and jewel mounted on a pivot, to rotate freely. The magnetic needle reading is taken when the bubble is

centered in the circular level. The lifting mechanism includes a needle lifting (locking) pin (fig 6-3) and a needle lifting lever. The lower end of the pin engages the lever. The upper end projects slightly above the body of the compass to engage the cover when it is closed, thereby automatically lifting the needle from its pivot and holding it firmly against the glass window.

(6) Azimuth scale adjuster assembly. The azimuth scale adjuster assembly rotates the azimuth scale to introduce the declination constant. Two teeth at the adjuster engage teeth on the underside of the azimuth scale, so that turning of the adjuster with a screwdriver rotates the azimuth scale approximately 1800 mils. The scale is read against a fixed index under the rear sight hinge.

b. Measuring azimuth.

CAUTION: When measuring an azimuth, no magnetic materials should be near the compass.

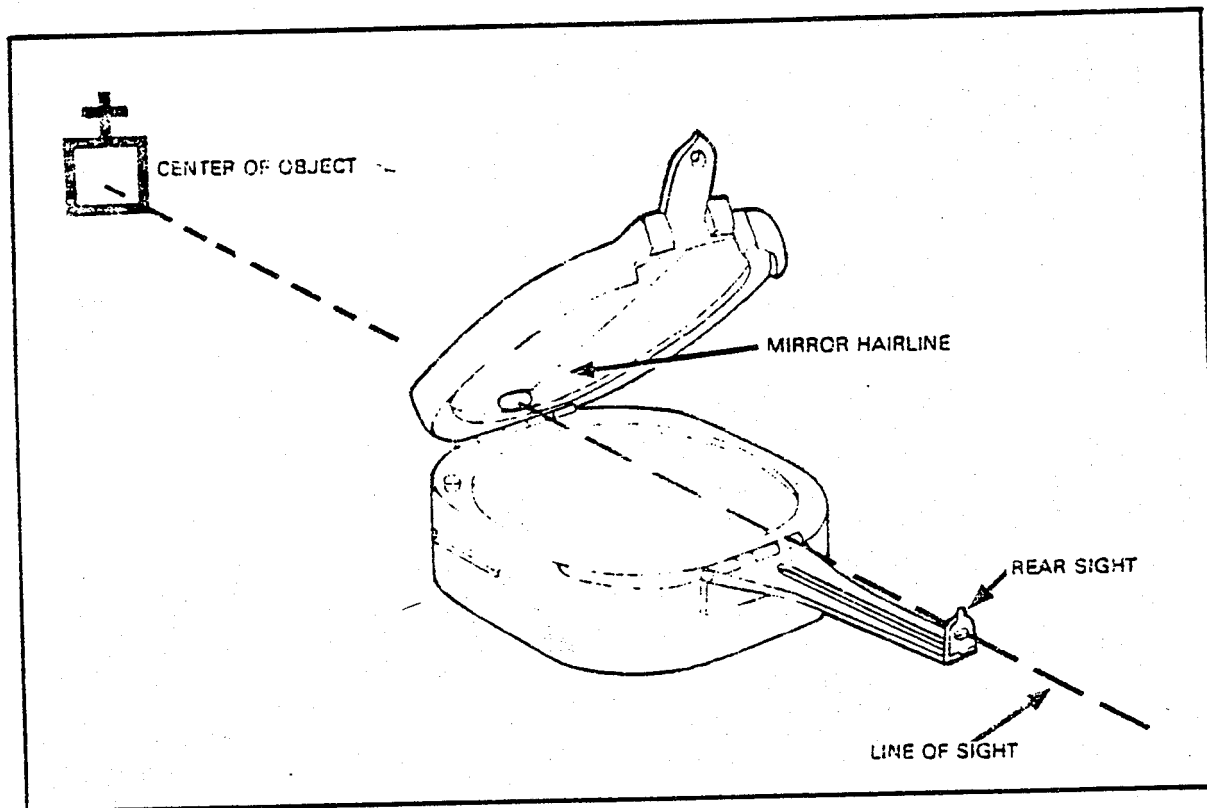

Figure 6-4. M-2 compass, observer's view.

To read the azimuth scale by reflection, hold the compass in both hands at eye level with arms braced against body and with the rear sight nearest the eyes. Place the cover at an angle of approximately 45° to the face of the compass (fig 6-4) so that the scale reflection can be

viewed in the mirror. Level the instrument by viewing the circular level in the mirror. Sight on the desired object and read the azimuth indicated on the reflected azimuth scale by the south-seeking end of the compass needle.

c. Care and handling. The M-2 compass will not stand rough handling or abuse; keep the compass in the carrying case protected from dust and moisture.

CHAPTER 7 COMBAT SERVICE SUPPORT

7-1. GENERAL

Organization, control, and supervision of combat service support (CSS) operations are vital to successful accomplishment of the mission. Providing logistical and administrative support is a significant challenge at the Pershing II firing battery level. Platoons are widely dispersed over large areas. Use of the radio to transmit logistics information must be kept to a minimum. Sustaining the combat effectiveness of each platoon is critical to success. This depends largely on the ability of the battery, support units, and higher headquarters to provide adequate and timely combat service support. This is achieved through comprehensive planning, coordination, and close supervision of the CSS effort. In CSS operations, every decision must be made to minimize vulnerability of units to being seen and located. This will help maximize unit survivability. Unit SOPs must be well thought out, and personnel must be trained on them. Combat service support consists of the logistical and administrative effort required to maintain the battery's capability to fight. The impetus of combat service support is from rear to front or as far forward as the tactical situation will permit. Within the battery, key personnel provide the direction and are responsible to maintain the unit's capability to fight.

7-2. RESPONSIBILITIES

- a. The battery commander has overall responsibility for combat service support operation and coordinates external support requirements.
- b. The battery executive officer establishes priorities for repair and monitors the prescribed load list (PLL).
- c. The battery first sergeant is responsible for administrative and supply operations.
- d. At the firing platoon level, the platoon leader and platoon sergeant share the above responsibilities.

7-3. CLASSES OF SUPPLY

Knowing the various classes of supply and how to request, procure, store and distribute supplies is essential to CSS operations. Supplies are grouped into the following 10 classes:

- a. Class I. Rations and gratuitous issues of health, morale and welfare items. Included are--
 - (1) Meals, ready to eat.
 - (2) Expendables such as soap, toilet tissue, and insecticide.

(3) Water.

b. Class II. Clothing equipment, tentage, tool sets and kits, hand tool sets, and administrative and housekeeping supplies/equipment.

c. Class III. Petroleum, oils and lubricants (POL).

d. Class IV. Construction materials to include camouflage, barrier and fortification material.

e. Class V. Ammunition.

f. Class VI. Personal demand items sold through the post exchange (PX).

g. Class VII. Major end items, such as trucks.

h. Class VIII. Medical supplies.

i. Class IX. Repair parts.

j. Class X. Nonstandard items to support nonmilitary programs.

7-4. BATTERY TRAINS

The combat service support elements of the battery consist of the support platoon, supply section and mess section. Collectively, these elements may be referred to as the battery combat trains.

a. In slow-moving situations, the battery trains will occupy tactical positions with the heavy platoon. When enemy counterfire is heavy, the battery trains may remain in a central location while the heavy platoon moves from one alternate firing position to another.

b. Wherever the battery trains is located, it must be able to provide responsive support to the firing platoon elements.

c. The tactical employment of the battery trains must consider:

(1) Cover and concealment.

(2) Access to resupply routes and to each firing platoon.

(3) Adequate area for resupply and maintenance operations.

(4) Location away from main enemy avenues of approach.

(5) Defensibility.

(6) Alternate positions.

7-5. SUPPLY OPERATIONS

Supplies are obtained by unit distribution (battalion/battery delivers) or by a supply point distribution (battery/platoon must pick up). The battery commander, executive officer, and first sergeant must continuously plan for and ensure that resupply is accomplished. Critical supplies such as rations, petroleum, oil and lubricants (POL), ammunition, repair parts, and NBC items must be extensively managed.

a. Rations. Three to five days of combat rations should be maintained within the battery. Combat rations are distributed to individuals and crews and carried on organic transportation. When the tactical situation permits, the battery/platoon mess section will prepare hot meals. Rations and water are obtained from the battalion through supply point distribution. Rations should be picked up, distributed, and prepared in a way that minimizes the possibility of being seen and identified by enemy agents. Platoons should be able to operate without resupply between unit movements. Extended use of combat rations should be planned for. Units should have sufficient water to preclude the need for resupply between unit moves.

b. Petroleum, oils, and lubricants (POL). Procurement of POL products includes fuels, packaged grease and lubricants. Each firing platoon has a fuel truck with two 600-gallon tanks and a tank and pump unit capable of dispensing from either tank and a trailer mounted tank. Battery and platoon resupply operations are coordinated with the battalion S4 and carried out in accordance with local policy. Depending on the tactical situation, POL products can be delivered to the battery headquarters area by the maintenance and supply (M&S) company of the maintenance battalion, or a centralized POL resupply point can be established. Within each firing platoon the vehicles and generators may be topped off in position by the fuel truck or they may be refueled enroute to the next position. Each firing platoon should maintain enough POL products to preclude need for resupply between unit movements. SOPs should include safety considerations, basic loads, prevention of contamination, and procedures to take when fuel is contaminated.

c. Ammunition resupply. Each light and heavy platoon position must be equipped with a basic load of small-arms ammunition to provide for independent operations. Ammunition stockage should ensure that each platoon can defend itself against small ground forces while maintaining a 360° perimeter. Use of smoke may be required for hasty evacuation. The capability for destruction of missiles and equipment to prevent enemy use must be continuously ensured. Missile resupply must be accomplished efficiently and must minimize unit vulnerability to being located by enemy agents or being attacked by small unit ground forces.

d. Repair parts. The prescribed load list (PLL) and essential repair parts stockage list (ERPSL) identify the quantity of combat-essential supplies and repair parts (class II, class IV, and class IX) authorized to be on hand or on order at all times. Standardized combat PLLs/ERPSLs are developed based on mandatory parts lists and demands.

The unit PLL clerk will manage the PLL and ERPSL and requisition repair parts when needed.

(1) PLL/ERPSL loads will be maintained so that they are readily accessible to maintenance personnel. Small PLL/ERPSL items will be carried in the maintenance truck or trailer. Larger or more bulky items should be carried in vehicles or trailers where the parts may be needed.

(2) The PLL clerk must maintain a card file with the amount and location of all PLL/ERPSL items.

(3) Repair parts will be requisitioned by the PLL clerk through the battalion maintenance section. From there, requisitions will be forwarded to the forward support company.

(4) Repair parts may be delivered to the battery by unit distribution.

e. Other supplies.

(1) Sundry items--tobacco, toilet articles, and candy--are issued with rations.

(2) Major end items--vehicles are issued directly to the unit based on tactical priorities and availability of equipment.

(3) Medical supplies are issued through medical channels.

(4) NBC items are class IX in nature but require special emphasis and close management by the battery NBC NCO.

(5) Maps are requisitioned and provided by the battalion S2.

7-6. FIELD SERVICES

Field services include laundry, bath, clothing exchange, bakery, textile renovation, salvage, graves registration, decontamination, and PX sales. Conduct of these services must be thoroughly described in local policies and SOPs. Thorough consideration must be given to survivability and operations in an NBC environment.

7-7. PERSONNEL SERVICES

Personnel services include personnel management, leaves and passes, postal service, religious activities, legal assistance, financial assistance, casualty and strength reporting, welfare activities, and rest and recreation. Together with ration support and provision of other CSS resources, these services are very important to maintaining morale among the troops. Unit leaders must know how personnel services will be maintained after the outbreak of hostilities. Pershing II unit locations must not be revealed to the enemy during personnel service activities.

ns are:

(1) Site selection.

7-8. HEALTH SERVICES

Health services include health preservation, field sanitation, immunization, medical and casualty evacuation, and safety. To effectively employ the Pershing II system, personnel must be in good physical condition and be able to perform with little rest for extended periods. Field sanitation and safety must be stressed at all levels of command. Immunizations must be kept current. Medical and casualty evacuation must be handled in accordance with local policies. Platoon positions should have medical personnel present with an ambulance located at the heavy position. Casualty evacuation procedures should be conducted to minimize the possibility of compromising position locations.

7-9. MAINTENANCE, REPAIR, AND RECOVERY

a. Our success on the battlefield is directly related to our ability to perform maintenance necessary to keep equipment and materiel in effective operating condition. When breakdowns do occur, equipment must be repaired as far forward as possible by the lowest capable echelon. When equipment must be moved, it is moved only as far as necessary for repair.

b. Responsibilities.

(1) Operator. Each item of equipment must have an assigned operator who is responsible for operator-level maintenance using the -10 technical manual.

(2) First line supervisor. He supervises the individual operator and crew in maintenance activities.

(3) Maintenance section. It performs battery level maintenance, which includes minor repairs, limited battlefield recovery, and assists in evacuation.

(4) Motor sergeant. He supervises the maintenance section and ensures necessary repair parts are requisitioned and required test equipment is available. He works directly for the motor officer.

(5) Motor officer. Normally, this is the support platoon leader. He supervises maintenance within the battery, and in conjunction with the XO, establishes priorities for repair.

c. The complete maintenance team consists of the operator and/or crew and battery maintenance personnel.

(1) The operator and/or crew must perform services on vehicles and equipment which are authorized in the -10 technical manual and include inspecting, servicing, tightening, lubricating, and care of tools. Equipment faults which cannot or should not be repaired by the

operator/crew will be recorded on a DA Form 2404, Equipment Inspection and Maintenance Worksheet, and submitted through the first line supervisor to the battery motor sergeant.

(2) The battery maintenance section will perform services listed in the -20 technical manual which include lubrication services, authorized repairs, road test, assistance in battlefield recovery, and limited assembly replacement.

(3) Equipment faults not authorized for organizational repair will be fixed or replaced by the battalion maintenance section or forward support maintenance company.

(a) The forward support company collocated with each FA battalion provides intermediate maintenance support except automotive maintenance. Automotive maintenance support is provided by the maintenance and support company of the maintenance battalion. A forward area support (FAS) team is attached to each firing battery when in the field to provide on-the-spot maintenance support. Maintenance beyond the capabilities of the FAS team is evacuated to the forward support company location for repair or evacuation to the maintenance battalion.

d. The battery has three recovery vehicles. One recovery vehicle is normally located with each firing platoon to expedite recovery operations. However, vehicles should be repaired on site, if possible, rather than evacuating them. Recovery of a vehicle stuck in mud should be performed using the vehicle's own winch, if possible. FM 20-22 provides detailed information and guidance for all recovery operations.

7-10. LOGISTICS RAID SITE

a. When the tactical situation warrants, a battalion/battery logistics raid site may be established to provide extensive combat service support assistance to the battery/platoon. This technique is used when a battery/platoon has been engaged in combat for a sustained period of time, requires major assistance in several areas at one time, and the supply point distribution method is determined most effective. This technique involves the movement of the battalion/battery combat service support elements to a location where the firing elements could pass through the logistics raid site and take on needed supplies, maintenance, etc. (fig 7-1). Following the logistics raid, the combat service support elements march order and proceed from the site to another location.

b. Some site considerations are:

(1) Site selection.

(a) On or near the route of march for the firing elements.

(b) Trafficability.

- (c) Cover and concealment.
- (2) Site organization.
 - (a) Dispersion.
 - (b) Camouflage.
 - (c) OPSEC.
- (3) Site activities.
 - (a) Brief key personnel (firing battery).
 - (b) Tailored to meet the needs of the unit.
 - (c) Petroleum, oil and lubricants, ammunition, maintenance, and rations (priorities).
 - (d) Local security (augmented by firing battery/
platoon).

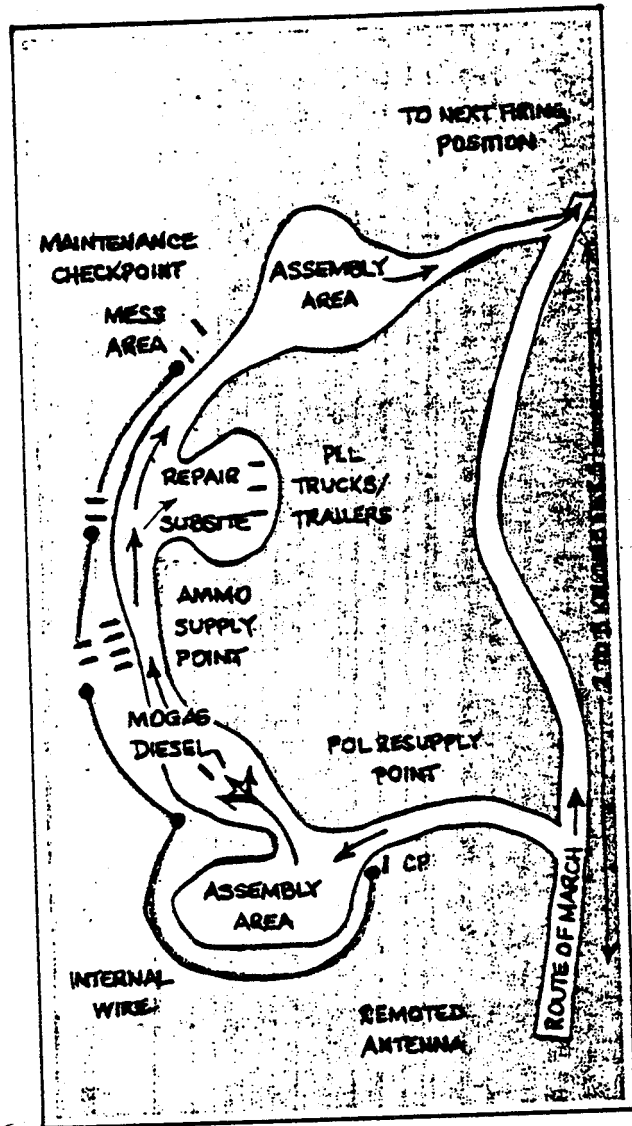

Figure 7-1. Logistics raid site.

CHAPTER 8 FIRING BATTERY COMMUNICATIONS

The Pershing battery must establish and maintain effective communications both internally and externally. This is a relatively complex task since firing platoons are located separately from the firing battery headquarters. To accomplish its mission, Pershing must be able to survive on the modern battlefield and produce timely, accurate fires on designated targets. This requires effective command and control, dissemination of intelligence, and coordination of defense and support operations through a reliable communications system. To ensure responsiveness, reliability, and survivability, all personnel within the battery must understand firing battery communications. Because of the sensitive OPSEC considerations associated with Pershing communications systems, a discussion of them is limited to the classified battalion/brigade field manual. The following is a discussion of survivability techniques/considerations applicable to any communications system.

8-1. COMMUNICATIONS SECURITY

Communications security (COMSEC) is designed to deny unauthorized persons information of value that might be derived from a study of our communications. COMSEC includes transmission security, cryptographic security, and physical security. It is the responsibility of each individual in the unit to maintain communications security. If an individual notes a COMSEC violation he must report it to his immediate supervisor.

8-2. CRYPTOGRAPHIC SECURITY

a. Cryptographic security is that portion of COMSEC that deals with the proper use of cryptosystems. All classified messages should be transmitted in cryptographic form unless urgency does not permit encrypting. The transmission of a classified message in the clear must be authorized by the commander or his specifically designated representative. The exception to this rule concerns messages classified TOP SECRET. These are never sent in the clear over electrical means.

b. All COMSEC personnel must be carefully trained in the use of the cryptosystems before being permitted to handle actual traffic. AR 380-40 and TB 380-41 should be used to thoroughly familiarize operators of cryptosystems with COMSEC procedures.

c. Secure communications systems that allow complete freedom and flexibility in the exchange of information are essential elements of military operations. However, emergency situations may arise when secure communications of any form are not available and immediate needs dictate the clear text electrical transmission of classified information. Information classified TOP SECRET may not be electrically transmitted in-the-clear over unsecured means at any time. During hostilities, CONFIDENTIAL and SECRET information may be electrically transmitted in-the-clear by unsecured means (such as telephone,

teletypewriter, and radio) as an emergency measure when all of the following conditions exist:

- (1) The transmitting or receiving station is located in a theater of actual hostilities.
- (2) Speed of delivery is essential.
- (3) Encryption cannot be accomplished.
- (4) Transmitted information cannot be acted upon by the enemy in time to influence current operations.

d. When CONFIDENTIAL or SECRET information must be transmitted in-the-clear, according to paragraph c, the following procedures will be followed:

(1) Each transmission in-the-clear must be individually authorized by the commander of the unit or element transmitting the message or by his or her designated representative.

(2) References to previously encrypted messages are prohibited.

(3) The classification will not be transmitted as part of the message. Messages will be identified by the word "CLEAR" in place of the classification.

(4) Each transmission in-the-clear must be individually authenticated using an approved authentication system (transmission authentication).

(5) When "emergency in-the-clear" communications are received, record or other hard copy messages will be marked "RECEIVED IN-THE-CLEAR HANDLE AS CONFIDENTIAL" before delivery to the addressees. In-the-clear messages will be handled as CONFIDENTIAL material and will not be readdressed. Should an addressee determine that the information must be forwarded to another addressee, a new message will be originated, classified, and handled as the subject matter and situation dictate.

8-3. VOICE/RADIO TRANSMISSION SECURITY

Radio is the least secure means of transmitting information, yet it is the means most frequently used in Pershing units. Transmission security procedures that apply to radio transmissions of all types are outlined as follows:

a. Call signs. Call signs are changed daily or as often as necessary to deny the enemy information regarding identification and disposition of tactical units (AR 105-64).

b. Assignment and changes. All call signs have a letter-number-letter configuration and are spoken phonetically (B2E--BRAVO TWO ECHO). These call signs are selected for assignment in a nonpredictable manner. The possibility of duplicated call sign/frequency assignments within an area has been essentially eliminated in the assignment program. The same call sign cannot be used within a corps rear area during its designated period. Higher and adjacent commands and other service elements will be furnished copies of the assigned documents. With the use of nonunique call signs, close liaison is required at all levels. Call signs are assigned to the specific unit and station, not to a net. Call sign changes must occur simultaneously with changes in frequencies.

c. Suffixes. All Army tactical units use changing suffixes (B2E41) along with changing call signs and frequency assignments. The rate of change for suffixes parallels that established for tactical call signs. A simple system has been devised to allow the rapid identification of those "out of net" stations. Instructions have been made for the stations normally operating within a net to use an abbreviated call sign (last letter of letter-number-letter call sign plus suffix number) for most operations. Also, other measures are taken to simplify operating procedures while enhancing security.

d. Accidental compromise. The purpose of call signs can be defeated when associated with other information that may identify the originator or addressee. Compromise can occur when current call signs are used in conjunction with superseded call signs, teletypewriter routing indicators, or corresponding plain text unit designators appearing in a message.

e. Classification. Operational call sign assignments of special significance, or those that are changed frequently for security reasons, must be classified at least CONFIDENTIAL.

f. Frequencies. Association of radio operating frequencies with a specific unit greatly helps Threat intelligence efforts. The actions cited below are designed to minimize Threat success.

(1) Assignment and changes. Frequencies should be assigned so that specific nets cannot be tracked easily. An identifiable pattern in assignments will be exploited by the Threat on the basis of frequency alone. Operating frequencies should be changed at least once each 24 hours to make continuous intercept difficult. Remember: Call signs must be changed when the operating frequency is changed.

(2) Accidental compromise. If notification of a frequency change must be made by radio, a secure means must be used to prevent accidental compromise.

(3) Classification. Operational frequency assignments of special significance, and those which are changed frequently for security reasons must be classified at least CONFIDENTIAL.

g. Operations and procedures. Adherence to communications procedures as outlined below is critical and will minimize the success of Threat intelligence efforts.

(1) Net discipline. Net discipline constitutes operation in accordance with prescribed procedures and security instructions. Such operations include--

- (a) Correct calling and operating procedures.
- (b) Use of authorized prosigns and prowords.
- (c) Operating at a reasonable speed.
- (d) Correct use of call signs.
- (e) Effective use of authentication.
- (f) Limiting transmissions to official traffic.
- (g) Use of secure devices, when applicable.

(2) Authentication. Authentication systems prevent unauthorized stations from entering friendly radio nets to disrupt or confuse operations. They also protect a communications system against false transmissions (imitative deception). The only authentication systems authorized for use in the US Army are those produced by NSA, or, for an emergency requirement, by INSCOM. If a special or emergency requirement arises, the unit commander must notify the controlling authority of the authentication system in use or the controlling authority's designated representative (C-E Officer).

(a) The two methods of authentication that are authorized for use are shown below. The operational distinction between the two is that challenge and reply requires two-way communications, whereas transmission authentication does not.

1. Challenge-reply authentication. In challenge-reply authentication, the called station always gives the first challenge. This challenge and reply method validates the authenticity of the calling station. It also prevents an unauthorized operator from entering a net to obtain authentication responses for use in another net. The station making the call may counterchallenge the called station, using a different challenge. Only the station responding to a challenge is verified. Do not accept a challenge as an authentication.

a. If an incorrect reply is received or if an unusual (15 to 20 seconds) delay occurs between the challenge and the reply another challenge should be made.

b. Operators will occasionally misauthenticate by using the wrong system or misreading the table. In such cases, the challenging station should attempt to pinpoint the difficulty and then rechallenge.

c. Never give the challenge and reply in the same transmission (self-authentication).

2. Transmission authentication. This is a method used by a station to authenticate a message. It is used when challenge-reply authentication is not possible; for example, when a station is under radio listening silence. Transmission authentication differs from self-authentications in that authenticators are either carefully controlled to ensure one-time use or are time based.

(b) Challenge and reply or transmission authentication systems, as appropriate, will be used when--

1. A station suspects imitative deception on any circuit.

2. A station is challenged to authenticate. Stations will not respond to a challenge when under an imposed radio listening silence.

3. Directing radio silence, radio listening silence, or requiring a station to break an imposed silence (transmission authentication).

4. Transmitting contact and amplifying reports in plain language.

5. Transmitting operating instructions that affect the military situation. Examples are closing down a station or watch, changing frequency other than normal scheduled changes, or directing establishment of a special communications guard. Other examples are requesting artillery fire support or directing relocation of units.

6. Transmitting a plain language cancellation.

7. Making initial radio contact or resuming contact after prolonged interruptions.

8. Transmitting to a station under radio listening silence (transmission authentication).

9. Authorized to transmit a classified message in the clear.

10. Forced, because of no response by the called station, to send a message in the blind (transmission authentication).

(3) Personal signs. Communications operators will not use personal signs, names, and other identifiers while passing traffic.

(4) Official messages. Traffic passed over military communications facilities must be limited to official messages.

(5) Emergency instructions. Communications operators and supervisors must be familiar with the emergency instructions for their operations. Also, these instructions must be immediately available. Compromised cryptosystems, authentication systems, call signs, and frequency assignments must be superseded as soon as possible. The procedure for supersession must be outlined in unit SOP.

(6) Antijamming measures. Operators must never reveal over nonsecure circuits an awareness of Threat jamming. Such an admission tells the Threat its effort was effective--a determination otherwise extremely difficult to be made. Other than physical destruction of Threat equipment, the best antijamming technique lies in thorough training of communications personnel (FMs 24-18 and 32-20 and TC 32-20).

(7) Antenna siting. Siting of a transmitting antenna on the reverse slope of a hill (away from the Threat) can reduce interception and direction-finding success.

(8) Power. Minimum power, consistent with operational range requirements, should be used. Power in excess of that required increases vulnerability to interception.

(9) Tuning and testing. When tuning or testing radio communications equipment, a dummy load should be used if available.

(10) Net control. Adherence to communications procedures is enforced by NCS personnel. Transmitted information of potential value to the Threat and deviations from prescribed procedures, which decrease the efficiency of radio nets, can be detected by net control. Based on the nature of the disclosures, operations can be carried out as planned, revised, or cancelled. In addition, remedial action can be initiated to preclude future occurrences.

(11) Directional antennas. The use of directional antennas lessens the amount of radio traffic available for Threat forces to intercept.

8-4. PHYSICAL SECURITY

Physical security pertains to those measures necessary to safeguard classified communications equipment and material from access by unauthorized persons. Unsuspected physical compromise is far more serious than known loss. If an undisclosed compromise occurs and the cryptosystem continues in use, the Threat may be able to decrypt all traffic sent in that system. Effective physical security insures the maximum protection of classified material from production to destruction. Classified

communications equipment and material can be protected from physical compromise by observing the following precautions:

- a. Proper handling by all personnel contacted.
- b. Adequate storage when not being used.
- c. Complete destruction when required.

8-5. SECURE AREA FOR COMSEC OPERATIONS

The same physical security principles that apply in a fixed cryptofacility apply equally to mobile cryptofacilities. While control procedures must be adapted to the field environment, they will, in effect, be no less stringent than those applied to fixed cryptofacilities. Commanders must ensure the following minimum requirements:

- a. Guards are the primary means of protection. Cleared operators working inside the cryptofacility fulfill this requirement.
- b. If operators are not inside the cryptofacility, the shelter door will be secured and guards provided to patrol the perimeter.
- c. A restricted area a minimum of 50 feet in diameter will be established and a guard will be posted at the entrance to control personnel access.
- d. During on-line cryptographic operations, all shelter windows and doors will remain closed.

8-6. COMSEC CONTROL AND ACCOUNTING

A control system that ensures the proper safeguarding and accounting for classified COMSEC material and information must be established and maintained. The establishment of an accurate and efficient system of accounting is of major importance in preventing the loss or physical compromise of COMSEC information. Such a system should include provisions for registration of the material to be protected, establishment of custodial responsibilities, maintenance of adequate records, and submission of timely and accurate reports. The guidance in TB 380-41 must be followed closely.

8-7. DESTROYING CLASSIFIED WASTE

Worksheets, excess copies, typewriter ribbons, carbon paper, and blotters used in preparing classified information will be given the same handling, storage and disposal as other classified material.

8-8. PACKING AND TRANSPORTING COMSEC MATERIAL

Ensure that authorized methods of packing and transporting COMSEC material meet standards prescribed in AR 380-40. Receipts will be

prepared using Standard Form (SF) 153 as prescribed by TB 380-41. Transportation of COMSEC material will be by officially designated means.

8-9. EMERGENCY EVACUATION OR DESTRUCTION OF COMSEC MATERIAL

To guard against the possible compromise of COMSEC material when a serious threat to the physical security of the material develops, emergency evacuation and destruction plans must be prepared. Various factors, such as the physical features of the area where the material is used, the availability of destruction material, the quantity of material to be destroyed, and the number of personnel available must be considered in plans. Provisions for the following must be included:

a. Emergency evacuation plans.

(1) Plans for emergency evacuation should--

(a) Assign specific responsibilities. Assignment should be made by duty position rather than by name, since emergencies can arise at any hour.

(b) Ensure that all assigned personnel are familiar with their duties under the plan. Training exercises should be held at regular intervals to ensure that each individual receives detailed instructions on his responsibilities in an emergency.

(c) Include information on the location of keys and combinations that might be required in an emergency.

(d) Provide for systematic evacuation of COMSEC information to a safe location under the direction of the responsible individual. Every effort should be made to prevent loss or unauthorized viewing during the period before the return of the information to the original location or its relocation in a new security area.

(2) Factors that would influence the decision to evacuate the COMSEC information include the:

- (a) Time available.
- (b) Future requirement for the COMSEC information.
- (c) Degree of hazard involved in the removal.
- (d) Safety of the new location.
- (e) Means of transportation available.
- (f) Transportation routes available.

(g) Provisions for precautionary destruction, as outlined in AR 380-40, after weighing the factors above.

b. Emergency destruction plans. In the preparation of emergency destruction plans, the factors used in the preparation of emergency evacuation plans will be considered. In addition, the priority of destruction of COMSEC material, as outlined in AR 380-40, will be included.

c. Violation report. Forward immediately to the controlling authority any report of physical security violations, whether known or suspected, as outlined in AR 380-40 or JCS Pub 13, volume I (S) or volume II (SFRD), as appropriate.

8-10. ELECTRONIC COUNTER-COUNTERMEASURES

a. In its broad aspects, electronic counter-countermeasures (ECCM) can be considered to deal with means to conceal friendly emitters or to deceive the enemy as to their identity and location. Command posts or weapon systems cannot survive on the modern battlefield if they are easily identified or located by--

- (1) The characteristics of their electronic emitters.
- (2) Incorrect operational procedures.

(3) Incorrect practices by users of communications equipment (fig 8-1). Thus, their survival depends on the development and use of good defensive electronic warfare (EW) tactics.

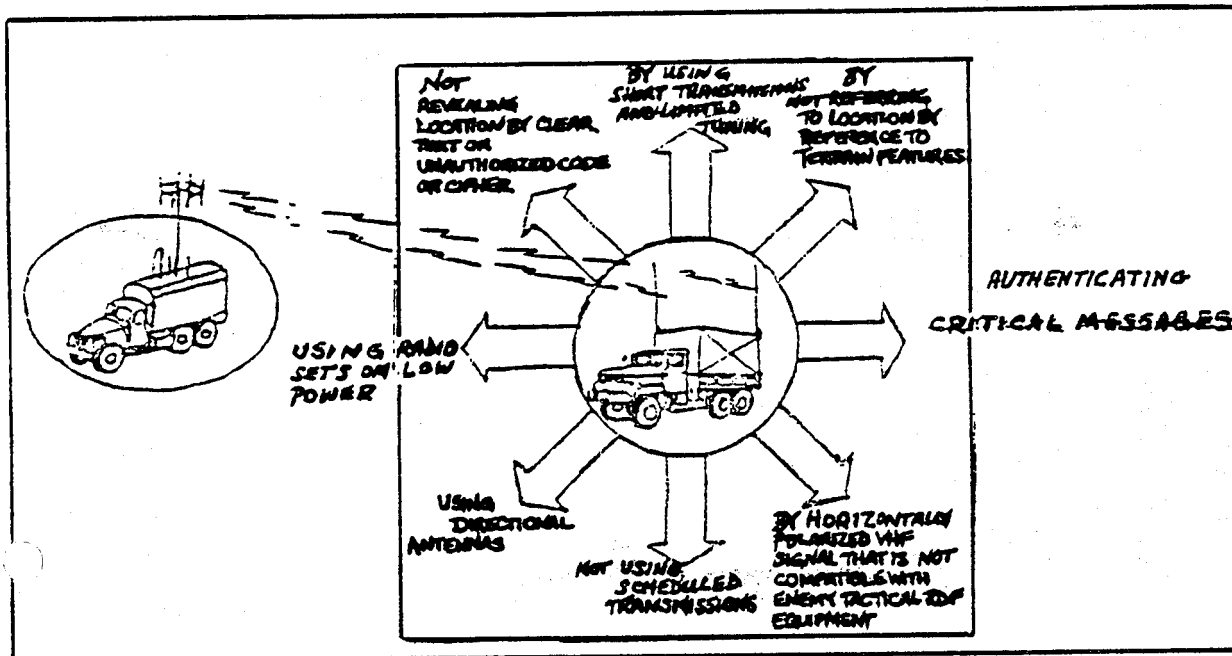

Figure 8-1. Correct communications practices.

b. A highly effective method for reducing the chance a signal will be intercepted by the enemy is to reduce communication time. Short communication as a counter-RDF technique is vital during the preparation phase and approach to a new area of operations or in the defense.

c. Identifiable electronic signatures and high transmission profiles can result from signal security violations and poor planning before and during an operation. Tactical communications should be used only to--

- (1) Rapidly convey decisions.
- (2) Key standing operating procedures.
- (3) Direct alternative courses of action or changes in mission requirements.

d. Execution of the unit mission must be inherent in training, planning, and teamwork. Vulnerability of communications to interception and direction-finding is indicated by the large volume and context of communications noted on command operations nets before a major operation. This pattern uniquely distinguishes the unit in the planning and preparation phase before a movement or a firing. The communications pattern depicted in figure 8-2 defies electronic concealment. There is too much traffic to be concealed. To eliminate this indicator, units

should strive to achieve a traffic pattern similar to the one depicted in figure 8-3 which does not indicate dramatic changes in traffic levels.

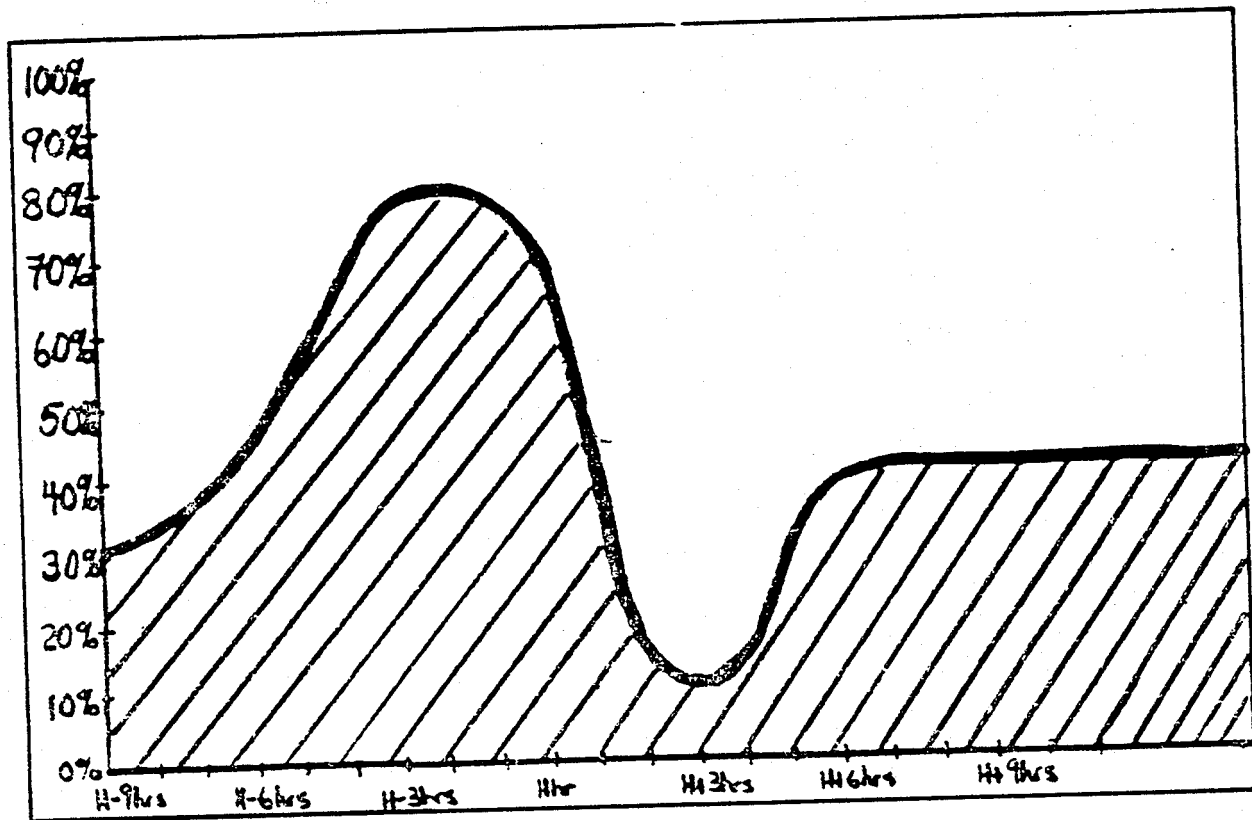

H-HOUR=MOVEMENT TIME

Figure 8-2. High traffic pattern example.

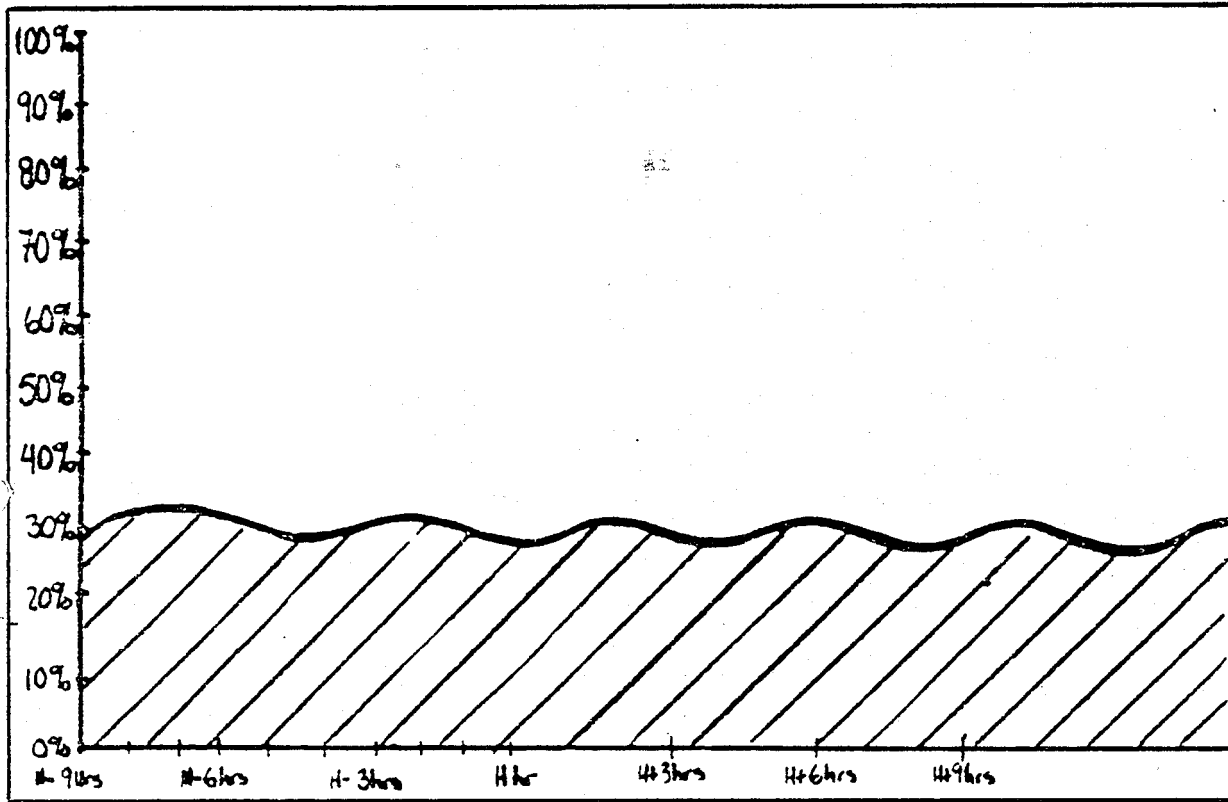

H-HOUR=MOVEMENT TIME

Figure 8-3. Low traffic pattern example.

e. New communications-electronics systems with low detectability signatures offer great potential for defeating the Threat radio-electronic combat (REC) capabilities. They make it more difficult to identify and locate critical targets.

f. The commander has other means available to manage the communications system of his unit.

(1) The communications-electronics operating instructions (CEOI) are used to assign specific frequencies and call signs to specific elements of a command. A frequently changing CEOI is very effective in defeating hostile REC activities. It makes it more difficult for the enemy to identify and exploit the emitters.

(2) Emission control is used by the commander to restrict use of assigned frequencies to certain critical radio nets or to prohibit radio use altogether (partial or complete silence). This tactic keeps the Threat from collecting data on our emissions during a specified period. Also, it greatly reduces the probability of mutual interference between friendly emissions and those of critically important radio nets. Restricting emissions to only a few critical systems may increase the vulnerability of those systems to interception and attack by the enemy. Hence, this tactic should be used with caution.

g. The use of any radio must be restricted to those individuals who have demonstrated skill in radio communications and are aware of the Threat's REC capabilities. In combat, misuse of the radio through ignorance, lack of training, or carelessness can result in death for an entire unit.

8-11. ELECTROMAGNETIC PULSE THREAT

The increased sophistication in nuclear strategy and weapons, coupled with the increased susceptibility of electronic systems due to use of semiconductors and greater dependence on automatic data processing systems, has greatly increased the significance of the electromagnetic pulse (EMP) threat. It is evident that the EMP effects on tactical communications could be quite severe. Only planned action and proper training to protect against EMP potential effects can preserve the equipment for use when needed. Maintenance and operational practices and procedures to reduce overall vulnerability can be established and practiced. The practical countermeasures listed below will be employed:

a. Alternate routing. Every supervisor and operator must be trained to establish alternate communications systems if the primary system is disrupted due to nuclear effects.

b. Communications cable. All cables within the command post area should be of minimum length, insuring no loops are present that can induce additional energy into the cable. Vans should be relocated if

necessary to ensure minimum use of cables. Cables should be buried when possible. When a nuclear strike is imminent, all electrical cables should be disconnected from their associated equipment (generators, radios, etc.). This will prevent EMP from being induced by these conductors and severely damaging additional equipment.

c. Repeating coils. Repeating coils (C161) must be used on voice and teletype wire circuits.

d. Maintenance. The integrity of shields, grounding systems, and protective devices must be maintained at all times. Special emphasis should be placed on replacing cables with damaged shielding or connectors.

e. Messenger service. Either air or motor messenger service should be considered as a primary means of information distribution in an EMP environment until alternate communications can be established.

f. Radio antennas. All antennas and their associated transmission lines (when applicable) should be disconnected from the radio sets when not in use. During periods of listening silence, transmit antennas should be disconnected. The shields of coaxial cables should be physically grounded to the shelter ground system at the location where the cable enters the shelter.

g. Shelter apertures. Doors, access panels, and all other apertures should be kept closed as much as possible to reduce the amount of direct EMP within communication shelters.

h. Spare equipment. Spare equipment should be stored in a protected location.

Note. Methods of protecting communications equipment from the effects of EMP apply equally to all electronic components, such as missile equipment.

APPENDIX A
REFERENCES

Department of the Army Pamphlets of the 310 series and TM 9-1425-386-L, List of Applicable Publications (LOAP) for Pershing II Field Artillery Missile System, should be consulted frequently for latest changes or revisions of references given and for new material on subjects covered in this manual.

A-1. Army Regulations (AR):

27-1	Judge Advocate Legal Services
30-1	Army Food Program
40-5	Health and Environment
40-583	Control of Potential Hazards to Health from Microwave and Radio Frequency Radiation
50-5	Nuclear Surety
(C)50-5-1	Nuclear and Chemical Weapons and Material Nuclear Surety (U)
(C)50-101	Safety Rules for the Operation of the Pershing Nuclear Weapon System (U)
55-203	Movement of Nuclear Weapons, Nuclear Components, and Related Classified Nonnuclear Materiel
75-1	Malfunctions Involving Ammunitions
95-1	Army Aviation: General Provisions and Flight Regulations
(C)105-2	Electronic Counter-Countermeasures (ECCM) Electronic Warfare Susceptibility and Vulnerability (U)
105-3	Reporting, Meaconing, Intrusion, Jamming, and Interference of Electromagnetic Systems
105-10	Communications, Economy, and Discipline
105-31	Record Communications
165-20	Duties of Chaplains and Commander's Responsibilities

A-1. Army Regulations (AR) (Continued):

190-11	Physical Security of Arms, Ammunition, and Explosives
190-28	Use of Force by Personnel Engaged in Law Enforcement and Security Duties
190-40	Serious Incident Report
210-130	Laundry/Dry Cleaning Operations
220-1	Unit Status Reporting
220-58	Organization and Training for Nuclear, Biological and Chemical Defense
310-1	Publications, Blank Forms, and Printing Management
340-2	Maintenance and Disposition of Records in TOE Units of the Active Army, the Army Reserve, and the National Guard
350-1	Army Training
350-2	Opposing Force (OPFOR) Program
350-4	Qualification and Familiarization with Weapons and Weapons Systems
360-5	Public Information
360-65	Establishment and Conduct of Field Press Censorship in Combat Areas
380-2	High Energy Laser System Technology, Security Classification
380-5	Department of the Army Information Security Program
(C)380-15	Safeguarding Classified NATO Information (U)
380-20	Restricted Areas
380-29	Rocket Propulsion Technology-Security Classification
(S)380-30	Reporting of Critical Intelligence Information (CRITIC) (U)

A-1. Army Regulations (AR) (Continued):

(S)380-35	Department of the Army Communications Intelligence Regulation (Supplement to DOD S-5200.17 [MZ] Special Security Manual [U])
(C)380-40	Policy for Safeguarding and Controlling COMSEC Information (U)
380-150	Access to and Dissemination of Restricted Data
380-200	Armed Forces Censorship
385-10	Army Safety Program
385-64	Ammunition and Explosives Safety Standards
530-1	Operations Security (OPSEC)
530-2	Communications Security
(C)530-3	Electronic Security (U)
(S)530-4	Control of Compromising Emanations (U)
600-10	The Army Casualty System
638-30	Graves Registration Organization and Functions in Support of Major Military Operations
672-5-1	Military Awards
700-65	Nuclear Weapons and Nuclear Weapons Materiel
702-5	Missile Firing Data Reports (RCS DRC 224)
703-1	Coal and Petroleum Products Supply and Management Activities
710-2	Supply Policy Below the Wholesale Level
710-9	Guided Missile and Large Rocket Ammunition Issues, Receipts, and Expenditures Report
725-50	Requisitioning, Receipt, and Issue System
735-5	General Principles, Policies, and Basic Procedures
735-11	Accounting for Lost, Damaged, and Destroyed Property

A-1. Army Regulations (AR) (Continued):

750-25-1 Army Test, Measurement, and Diagnostic
Equipment (TMDE) Calibration and Repair Support
Program

750-40 Missile Materiel Readiness Report

A-2. Department of Army Pamphlet (DA Pam):

1-2 Personnel Administrative Center (PAC): Guide
for Administrative Procedures

50-3 The Effects of Nuclear Weapons

(C)310-9 Index of Communications Security (COMSEC)
Publications (U)

(C)380-2 SIGSEC: Defense Against SIGINT (U)

385-1 Unit Safety Management

600-8 Military Personnel Management and
Administrative Procedures

600-8-1 SIDPERS Unit Level Procedures

738-750 Maintenance Management Update

750-1 Organizational Maintenance Guide for Leaders

A-3. Field Manuals (FM):

3-3 NBC Contamination Avoidance

3-4 NBC Protection

3-5 NBC Decontamination

3-12 Operational Aspects of Radiological Defense

3-15 Nuclear Accident Contamination Control

3-21 Chemical Accident Contamination Control

3-22 Fallout Prediction

3-50 Chemical Smoke Generator Units and Smoke
Generation

A-3. Field Manuals (FM) (Continued):

3-54E1/2	Trainer's Guide: 54E, NBC Specialist
3-87(HTF)	Nuclear, Biological, and Chemical (NBC) Reconnaissance and Decontamination Operations (How to Fight)
3-100	NBC Operations
5-15	Field Fortifications
5-20	Camouflage
5-25	Explosives and Demolitions
5-36	Route Reconnaissance and Classification
5-100	Combat Engineer Operations
6-2	Field Artillery Survey
STP 6-15E1-SM	Soldier's Manual: Pershing Missile Crewman (Skill Level 1)
STP 6-15E2/3/4-SM/TG	Soldier's Manual/Trainer's Guide: Pershing Missile Crewman (Skill Level 2/3/4)
6-20-1(HTF)	Field Artillery Cannon Battalion (How to Fight)
6-20-2	Division Artillery, Field Artillery Brigade, and Field Artillery Section (Corps)
STP 6-21G1/2/3-SM/TG	Soldier's Manual/Trainer's Guide: Pershing Missile Repairman (Skill Level 1/2/3)
6-50	Field Artillery Cannon Battery
6-82C1 Surveyor	Soldier's Manual: 82C, Field Artillery
6-82C2/3/4-SM/TG	Trainer's Guide: Field Artillery Surveyor and Soldier's Manual (Skill Level 2/3/4)
7-7	The Mechanized Infantry Platoon/Squad
8-10	Health Service Support to Theater of Operations
8-35	Evacuation of the Sick and Wounded
9-6	Ammunition Service in the Theater of Operations

A-3. Field Manuals (FM) (Continued):

9-13	Ammunition Handbook
9-59	Unit Operations for Support of Missile and Air Defense Gun Systems
9-207	Operation and Maintenance of Ordnance Materiel in Cold Weather (0 to 65 degrees F)
10-14 Procedures)	Unit and Organization Supply (Manual
10-23	Army Food Service Operations
10-24	Ration Distribution Operations
10-60	Subsistence Supply and Management in Theaters of Operations
10-63	Handling of Deceased Personnel in Theaters of Operation
10-76Y/TG	Trainer's Guide 76Y, Unit Supply Specialist
10-76Y1/2	Soldier's Manual: 76Y, Unit Supply Specialist (Skill Level 1/2)
10-94B1/2	Food Service Specialist
10-94B3/4	Food Service Specialist
11-36K	Commander's Manual: 36K Tactical Wire Operations Specialist
11-50(HTF)	Combat Communications Within the Division (How to Fight)
11-65	High Frequency Radio Communications
16-5	The Chaplain
19-4	Military Police Combat Support, Theater of Operations
19-25	Military Police Traffic Operations
19-30	Physical Security
20-22	Vehicle Recovery Operations
20-31	Electric Power Generation in the Field

A-3. Field Manuals (FM) (Continued):

20-32	Mine/Countermine Operations at the Company Level
21-2	Soldier's Manual of Common Tasks (Skill Level 1)
21-3	Soldier's Manual of Common Tasks (Skill Level 2/3/4)
21-6	How to Prepare and Conduct Military Training
21-10	Field Hygiene and Sanitation
21-11(Test)	First Aid for Soldiers
21-20	Physical Readiness Training
21-26	Map Reading
21-26-1	Map Reading
21-30	Military Symbols
21-33	Terrain Analysis
21-40	NBC (Nuclear, Biological and Chemical) Defense
21-48	Planning and Conducting Chemical, Biological, Radiological (CBR) and Nuclear Defense Training
21-60	Visual Signals
21-75	Combat Training of the Individual Soldier and Patrolling
21-305	Manual for the Wheeled Vehicle Driver
22-6	Guard Duty
24-1(HTF)	Combat Communications (How to Fight)
24-16	Communications-Electronics: Operations Orders, Records and Reports
24-17	Tactical Communications Center Operations
24-18	Field Radio Technique
24-20	Field Wire and Field Cable Techniques

A-3. Field Manuals (FM) (Continued):

24-22 (CEMS)	Communications-Electronic Management System
25-2	How to Manage Training in Units
29-2	Organizational Maintenance Operations
29-27	Calibration and Repair Service in the Theater of Operations
30-5	Combat Intelligence
30-16	Technical Intelligence
30-28	Armed Forces Censorship
30-102	Opposing Forces, Europe
(C)31-40	Tactical Cover and Deception (U)
31-70	Basic Cold Weather Manual
31-85	Rear Area Protection (RAP) Operations
32-6	SIGSEC Techniques
32-7	Signal Security Instructional Packet
(C)32-9	ELSEC Techniques (U)
(C)32-20	Electronic Warfare (EW) (U)
32-30	Electronic Warfare, Tactics of Defense
38-1	Logistics Management
44-8	Small Unit Self Defense Against Air Attack
54-7	Theater Army Logistics
55-12	Movement of Army Units in Air Force Aircraft
55-30	Army Motor Transport Units and Operations
57-38	Pathfinder Operations
90-2(HTF)	Tactical Deception (How to Fight)
90-3	Desert Operations

A-3. Field Manuals (FM) (Continued):

90-10	Military Operations on Urbanized Terrain
90-13	River Crossing Operations
100-5 (HTF)	Operations (How to Fight)
100-16	Support Operations, Echelons Above Corps
100-50	Operations for Nuclear-Capable Units
101-5	Staff Officer's Field Manual: Staff Organization and Procedure
101-5 (HTF)	Operational Terms and Graphics (How to Fight)
101-10-1	Staff Officer's Field Manual: Organizational, Technical, and Logistical Data (Unclassified Data)
101-31-1	Staff Officer's Field Manual: Nuclear Weapons Employment Doctrine and Procedures

A-4. Supply Bulletins (SB):

9-151	Safety Labeling for Storage and Shipment of Acids, Adhesives, Cleaners, Preservatives, and Other Related Material
11-131 Installations	Vehicular Radio Sets and Authorized
11-569	Replacement and Disposition of Cable Assemblies, Telephone, CX-4566/G and CX-4760/U Containing Unsuitable Contact Assemblies
38-100	Preservation, Packaging, Packing and Marking Materials, Supplies and Equipment Used by the Army
700-20	Army Adopted/Other Items Selected for Authorization/List of Reportable Items
700-21	Area Standardization of Army Equipment
740-1	Storage and Supply Activities; Covered and Open Storage
742-1	Ammunition Surveillance Procedures
746-1	Publications for Packaging Army General Supplies

A-5. Supply Catalogs (SC):

1375-95-CL-A04	Demolition Equipment Set, Explosive Initiating, Nonelectric
4910-85-CL-A72	Shop Equipment, Automotive Maintenance and Repair: Organizational Maintenance, Common No 2, Less Power
4910-95-CL-A73	Shop Equipment, Automotive Maintenance and Repair: Organizational Maintenance, Supplemental No 1, Less Power
4910-95-CL-A74	Shop Equipment, Automotive Maintenance and Repair: Organizational Maintenance Common No 1, Less Power
4933-95-CL-A07	Tool Kit, Small Arms Repairman
5180-90-CL-N01	Tool Kit, TE50-B
5180-90-CL-N08	Tool Kit, Carpenter's Engineer Squad
5180-90-CL-N18	Tool Kit, Refrigeration Unit
5180-90-CL-N26	Tool Kit, General Mechanics: Automotive
5180-91-CL-R13	Tool Kit, Electronic Equipment, TK-101/G
5180-95-CL-A31	Tool Kit, Special Weapons: Organizational Maintenance, (Pershing)
5180-95-CS-A44	Tool Kit, Guided Missile, Mechanical Assembler, Missile Mating (Pershing)
5180-95-CL-A45	Tool Kit, Guided Missile, Mechanical Assembler, Firing Site (Pershing)
5975-91-CL-D01	Splicing Kit, Telephone Cable MK-356/G
6230-97-CL-E01	Light Set, General Illumination: 25 Outlet (NSN 6230-00-299-7077) (LIN L63994)
6545-8-CL-D27	Medical Equipment Set, Battalion Aid Station
6675-90-CL-N02	Plotting Set, Artillery Fire Control
6675-90-CL-N04	Drafting Equipment Set, Battalion: For Charts, Sketches and Overlays
7360-90-CL-N02	Range Outfit, Field, Gasoline

A-6. Technical Bulletins (TB):

CML 59	Mask, Protective, Headwound, M18
MED 269	Carbon Monoxide: Symptoms, Etiology, Treatment, and Prevention of Overexposure
MED 523	Control of Hazards to Health from Microwave and Radio Frequency Radiation and Ultrasound
MED 530	Food Services Sanitation
9-337	Guided Missile Systems: Corrosion Control and Treatment
9-380-101-6	Security Classification Guide for Guided Missile System, Artillery (Pershing 1A and 2)
(CFRD) 9-1100-802-50	Changing Combinations on Nuclear Weapons Locking Devices (U)
9-1100-803-15	Army Nuclear Weapons Equipment Records and Reporting Procedures
9-1425-386-14-1	Color and Marking of Pershing II Missile and Support Equipment
9-2300-421-20	Replacement of Red Interior Domelight Blackout Lens with Blue Domelight Blackout Lens
9-4935-262-50-1	Calibration Procedure for Electrical Cable Test Set, AN/GSM-45
9-5120-202-35	Calibration Procedure for Torque Wrenches and Torque Screwdrivers
9-6625-990-35	Calibration Procedures for Multimeters AN/URM-105, AN/URM-105B, AN/105C, ME-77U, ME-77A-U, ME-77B-U, ME-77-CU, TS-297()/U and Triplet Model 650; and Vacuum Tube Volt-Ohmmeter Simpson Model 303
9-6625-2051-35	Calibration Procedure for Radio Test Set, AN/PRM-34
ORD 5100-30/3	2½-Ton, 6x6 Cargo Truck, M35 on M211 and M1: Cargo Trailer, M103 or M105; Location and Installation of Common Set No 2 Organizational Maintenance (2d Echelon) Tool Set
11-5820-401-20	Radio Set AN/VRC-46: Maintenance Place Card

A-6. Technical Bulletins (TB):

SIG 226-8 Charger, Radiac Detectors PP-1578/PD and
PP-1578A/PD (NSN 6665-00-542-1177)

SIG 226-9 Field Expedient for Charging Radiac Meters
IM-93/UD and IM-147/PD

43-0121 Inspection and Certification of Radiac Meters
(Dosimeters), IM-9()/PD, IM-93()/PD,
IM-147()/PD, and IM-185()/PD

43-0142
Devices Safety Inspection and Testing of Lifting

43-180 Calibration Requirements for the Maintenance of
Army Materiel

(C)380-4 Electronic Security Design Criteria for Non-
communications Electromagnetic Equipment (U)

385-2 Nuclear Weapons Firefighting Procedures

746-95-1 Color, Marking, and Camouflage Pattern Painting
for Armament Equipment

750-92-1 Maintenance Expenditure Limits for Guided
Missiles

750-97-28 Maintenance Expenditure Limits for Military
Standard Engines (Military Design) and Outboard
Motors

A-7. Technical Manuals (TM):

3-220 Chemical, Biological, and Radiological (CBR)
Decontamination

3-4230-204-12&P Operator's and Organizational Maintenance
Manual (Encl RPSTL) for Decontaminating
Apparatus ABC-M-11

3-4230-211-10 Operator's Manual: Mask, Chemical-Biological:
Field, ABC-M17, M17A1 and M17A2.

3-4240-298-20&P Collective Protection Equipment, Pershing II,
Consisting of Entrance, Protective,
Pressurized, Collapsible, XM14; Filter Unit,
Gas Particulate, 200 CFM, 208V, 400 Hz (Encl
RPSTL)

A-7. Technical Manuals (TM) (Continued):

3-4240-298-SP&P	Static Frequency Converter: XMS Modular Collective Protection Equipment (Encl RPSTL)
3-6665-225-12	Operator's and Organizational Maintenance Manual: Alarm, Chemical Agent, Automatic: Portable, Manpack, M8
3-6665-260-14	Operator's Through Depot Level Maintenance Manual: Test Set, Chemical Agent Automatic Alarm: M74
3-6665-261-14	Operator's Through Depot Level Maintenance Manual: Power Supply, Chemical Agent Automatic Alarm: M10
3-6665-302-10	Operator's Manual: Detector Unit, Chemical Agent Automatic Alarm: M42
3-6665-304-10	Operator's Manual: Area Predictor, Radiological Fallout ABC-M52AZ
3-6665-307-10	Operator's Manual: Detector Kit, Chemical Agent: M256
3-6910-227-10	Operator's Manual: Training Set, Chemical Agent Identification: Simulants, M72AZ
5-200	Camouflage Materials
5-235	Special Surveys
5-241-1	Grids and Grid References
5-241-2	Universal Transverse Mercator Grid: Zone to Zone Transformation Tables
5-315	Firefighting and Rescue Procedures in Theaters of Operations
5-180-200-10	Operator's Manual: Camouflage Screen System: Woodland Lightweight, Radar Scattering
5-2805-203-14	Operator's Through Depot Level Maintenance Manual: Engine, Gasoline, 6 HP (Military Standard Models DOD 4A132-1 and 4A032-2)
5-2805-257-14	Operator's Through Depot Level Maintenance Manual: Engine, Gasoline, 3 HP (Military Standard)

A-7. Technical Manuals (TM) (Continued):

- 5-2805-258-14 Operator's Through Depot Level Maintenance Manual: Engine, Gasoline, 10 HP (Military Standard)
- 5-2805-259-14 Operator's Through Depot Level Maintenance Manual: Engine, Gasoline, 20 HP (Military Standard)
- 5-4120-371-14 Operator's Through Depot Maintenance Manual: Air Conditioner, Compact Verticle, 208V 3 Phase, 50/60 HZ (Model # F18T-25) (NSN 4120-01-114-2471)
- 5-4310-227-15 Operator's Through Depot Maintenance Manual: Compressor, Reciprocating, Power Driven, Air: Gasoline Engine, 15 CFM, 175 PSI
- 5-4310-241-15 Operator's Through Depot Maintenance Manual: Compressor, Reciprocating: Air, 5CFM, 175 PSI, Hand Truck Mounted; Gasoline Engine Driven
- 4-4930-220-12 Operator's and Organizational Maintenance Manual (Encl RPSTL): Tank Unit, 600 Gallon Liquid Dispensing for Trailer Mounting
- 5-4930-228-14 Operator's Through General Support Maintenance Manual: Tank and Pump Unit, Liquid Dispensing for Truck Mounting
- 5-6115-271-14 Operator's Through General Support Maintenance Manual: Generator Set, Gasoline Engine Driven, Skid MTD, Tubular Frame, 3 KW, 3 Phase, AC, 120/280V, 28VDC (Less Engine)
- 5-6115-275-14 Operator's Through General Support Maintenance Manual: Generator Set, Gasoline Engine Driven, Skid MTD, Tubular Frame, 10 KW, AC, 120/208V, 3 Phase and 120/240V Single Phase (Less Engine)
- 5-6115-323-14 Operator's Through Depot Maintenance Manual: Generator Set, Gasoline Engine Driven, Skid MTD, Tubular Frame, 1.5 KW, Single Phase, AC, 120/240V, 28VDC (Less Engine)
- 6-6115-332-14 Operator's Through Depot Maintenance Manual: Generator Set, Tactical, Gasoline Engine: Air Cooled, 5 KW AC, 120/240V, Single Phae, 120/208V, 3 Phase, Skid MTD, Tubular Frame (Less Engine)

A-7. Technical Manuals (TM) (Continued):

5-6115-365-15 Operator's Through Depot Maintenance Manual (Encl EPSTL): Generator Sets, Gasoline and Diesel Engine Driven, Trailer Mounted, PU 619/M

6-6115-465-12 Operator's and Organizational Maintenance Manual: Generator Set, Diesel Engine Driven, Tactical, Skid MTD, 30 KW, 3 Phase, 4 Wire, 120/208V and 240/416V

5-6115-594-14&P Operator's Through General Support Maintenance Manual (Encl RPSTL): Generator Sets, Diesel Engine Driven, Trailer Mounted, PU-405 A/M, PU-406 B/M, PU-732/M, PU-760/M, PU-707/M, PU-495 A/G, AN/MJQ-10A, and AN/MJQ-15.

5-6130-301-13&P Operator's Through Direct Support Maintenance Manual (Encl RPSTL): Battery Charging Distribution Panel

5-6665-203-13 Operator's Through Direct Support Maintenance Manual: Detecting Sets, Mine AN/PSS-11

5-6665-293-13&P Operator's Through Direct Support Maintenance Manual (Encl RPSTL): Detecting Sets, Mine AN/PRS-7 and AN/PRS-8

5-6675-200-14 Operator's Through General Support Maintenance Manual: Theodolite: Directional 5.9-Inch Long Telescope: Detachable Triback w/Accessories and Tripod

5-6675-308-12 Operator's and Organizational Maintenance Manual: Position and Azimuth Determining System, AN/USQ-70

6-231 Seven Place Logarithmic Tables

743-200-1-2-3 Storage and Materials Handling

750-244-2 Procedures for Destruction of Electronics Material to Prevent Enemy Use

750-244-6 Procedures for Destruction of Tank-Automotive Equipment to Prevent Enemy Use

9-1005-224-10 Operator's Manual: M60, 7.62-mm Machine Gun

9-1005-237-15 Operator's Through Depot Maintenance Manual (Encl RPSTL): Bayonet-Knife w/Scabbard

A-7. Technical Manuals (TM) (Continued):

9-1005-249-10	Operator's Manual: M16A1 Rifle
9-1010-221-10	Operator's Manual: 40-mm Grenade Launcher, M203
(CRD)9-1115-230-14&P	Operator's Through General Support Maintenance Manual (Encl RPSTL): Trainer M271 (U)
9-115-386-12&P	Operator's and Organizational Maintenance Manual (Encl RPSTL) M266 Nuclear Warhead Section, M272 Training Warhead Section
(SRD)(N)9-1185-230	Equipment Ordinance Disposal Manual (U)
9-1240-381-10	Operator's Manual: Binocular M19 W/E
9-1300-206	Ammunition and Explosive Standards
9-1375-213-12	Operator's and Organizational Maintenance Manual (Encl RPSTL): Demolition Materials
9-1410-387-12	Pershing II Surface Attack Guided Missile
9-1425-386-L	Pershing II List of Applicable Publications (LOAP)
9-1425-386-HR	Pershing II Hand Receipt and Inventory List
9-1425-386-10-1	Pershing II Weapon System (System Description)
9-1425-386-10-2/1	Pershing II Weapon System (Firing Position Procedures) Volume 1 Tabulated Procedures
9-1425-386-10-2/2	Pershing II Weapon System (Firing Position Procedures) Volume II Detailed Procedures for EL OP and PCC CM1
9-1425-386-10-2/3	Pershing II Weapon System (Firing Position Procedures) Volume III Detailed Procedures for CM1 Through CM4 and PCC CM2
9-1425-386-10-3/1	Pershing II Weapon System (Missile Assembly)
9-1425-386-10-3/2	Pershing II Weapon System (Missile Disassembly)
9-1425-391-14	Facilitized Electrical Equipment Shelter
9-1430-388-12	Reference Scene Generation Facility
9-1430-392-10	Platoon Control Central (Operator's Manual)

A-7. Technical Manuals (TM) (Continued):

9-1430-392-20	Platoon Control Central (Organizational Maintenance Manual)
9-1430-393-14	Guided Missile System Electrical Cable Assembly Set and Rear Area Electrical Cable Assembly Set
9-1440-389-10	Erector Launcher, Guided Missile, Semitrailer Mounted XM 1003 (Operator's Manual)
9-1440-389-20	Erector Launcher, Guided Missile, Semitrailer Mounted XM 1003 (Organizational Maintenance Manual)
9-1450-387-13	Operator's Through Direct Support Maintenance Manual: Rear Area Power Unit
9-1450-396-14	Operator's Through Direct Support Maintenance Manual: Ground Handling Equipment
9-2320-209-10-1	Operation, Installation and Reference Data for 2½-ton, 6x6, M44A1 and M44A2 Series Truck (Multifuel): Cargo: M35A1 with and Without Winch, M35A2C, M35A2
9-2320-209-10-2	Scheduled Maintenance Operator Level for 2½-Ton-----
9-2320-209-10-3	Troubleshooting Operator Level for 2½-Ton-----
9-2320-209-10-4	Maintenance Operator Level for 2½-Ton-----
9-2320-209-20-1	Scheduled Maintenance Organizational Level for 2½-Ton-----
9-2320-209-20-2-1	Organizational Level 2½-Ton-----
9-2320-209-20-2-2	Organizational Level 2½-Ton-----
9-2320-209-20-3-1	Organizational Level 2½-Ton-----
9-2320-209-20-3-2	Organizational Level 2½-Ton-----
9-2320-209-20-3-3	Organizational Level 2½-Ton-----
9-2320-209-20-3-4	Organizational Level 2½-Ton-----
9-2320-272-10	Operator's Manual: M939 Series Vehicles (M928 5-Ton Cargo Truck and M931 Tractor Truck)
9-2320-272-10-HR	Hand Receipt Manual: M939 Series Vehicles

A-7. Technical Manuals (TM) (Continued):

9-2320-272-20-1 Organizational Maintenance Manual: M939 Series Vehicles (Volume 1)

9-2320-272-20-2 Organizational Maintenance Manual: M939 Series Vehicles (Volume 2)

9-2320-279-10 Operator's Manual: 10-Ton HEMTT

9-2320-279-10-HR Hand Receipt Manual: 10-Ton HEMTT

9-2320-279-20 Organizational Maintenance Manual: 10-Ton HEMTT

9-2320-282-10 Operator's Manual: XM 1002 Truck and XM 1002 Wrecker

9-2320-282-10 Hand Receipt Manual: XM 1002 Truck and XM 1002 Wrecker

9-2320-282-20 Organizational Maintenance Manual: XM 1002 Truck and XM 1002 Wrecker

9-2330-205-14 Operator's Through General Support Main Manual (Encl RPSTL): Chassis, Trailer, Generator, 2½-Ton 2 Wheel, M200A1

9-2330-213-14 Operator's Through General Support Maintenance Manual (Encl RPSTL): Chassis, Trailer, 1½-Ton 2 Wheel, Trailer Cargo, and Trailer, Tank Water

9-2330-246-14&P Operator's Through General Support Maintenance Manual (Encl RPSTL): Semitrailer, Van: Electronic 6-Ton, 2 Wheel

9-2330-358-14&P Operator's Through General Support Maintenance Manual (Encl RPSTL): Semitrailer, Tactical, Dual Purpose, Breakbulk/Container Transporter, 22½-Ton, M871

9-2330-364-14&P Operator's Through General Support Maintenance Manual (Encl RPSTL): Semitrailer, Van XM 1006

9-4935-262-14 Operator's Through General Support Maintenance Manual: Electrical Cable Test Set, AN/GSM-45

9-4935-387-14 Operator's Through General Support Maintenance Manual: Test Set, Safe and Arm Recoding

9-4935-394-14 Mechanical and Electrical Shop Sets

A-7. Technical Manuals (TM) (Continued):

9-4935-395-14	Preservation and Packaging Shop, Supply Office, and Repair Parts Shop
9-4935-396-14	Electronic Filter Test Set
9-6920-387-14	First Stage Trainer MT-1, Second Stage Trailer MT-2, G&CA Section Trainer MT-3, Radar Section Trainer MT-6, and Missile Simulator ES-1
9-6920-388-14	RSGF Trainer
9-6920-389-14	Simulator, Missile/Erector Launcher/Ground Integrated Electronic Unit
9-6920-392-14	Platoon Control Central Guided Missile System Trainer
9-8140-395-14	Shipping and Storage Containers
10-412	Armed Forces Recipe Service
10-7360-204-13&P	Operator's Through Direct Support Maintenance Manual (Encl RPSTL): Range Outfit, Field: Gasoline; Burner Unit, Gasoline; Accessory Outfit, Gasoline, Field Range w/Baking Pack
10-7360-206-13	Operator's Through Direct Support Maintenance Manual: Kitchen, Field, Trailer MTD
11-337	Telephone Sets TA-43/PT and TA-263/PT
11-362	Reel Units, RL-31, RL-31-B, RL-31-C, RL-31-D, and RL-31-E (Encl RPSTL)
11-381	Cable Assembly CX-1065/G: Telephone Cable Assemblies CX-1606/G and CX-1512/U: Telephone Loading Coil Assembly CU-260/G: Electrical Connector Plugs U-176/G and U-226/G and Maintenance Kit, Cable Splicing MK-640/G
11-490	Army Communications Facilities: Autodin Station and Teletypewriter Station Operating Procedures
11-490-2	Army Communications Facilities: Telecommunications Center Operating Procedures
11-2134	Manual Telephone Switchboard, SB-86/P; Installation and Operation

A-7. Technical Manuals (TM) (Continued):

11-2300-351-14&P-22 Operator's Through General Support Maintenance Manual (Encl RPSTL): Installation Kit, Electronic Equipment MK-1234/GRC in Truck, Utility ½-Ton for Radio Sets AN/GRC-125, AN/GRC160, AN/VRC-160, AN/VRC-46, AN/VRC-53, and AN/VRC-64.

11-2300-351-15-1 Installation of Radio Set, AN/GRC-106 in Truck, Util, ½-Ton

11-2300-351-15-5 Installation of Radio Set, AN/VRC-47 in Truck, Util, ½-Ton

11-2300-351-15-6 Installation of Radio Set, AN/VRC-49 in Truck, Util, ½-Ton

11-2300-459-14&P Operator's Through General Support Maintenance Manual (Encl RPSTL) Installation Kit, Electronic Equipment, MK-1813/VRC-49 and Difference Kit for Radio Set, AN/VRC-49 in Truck, 1½-Ton, M882 or M892

11-2300-459-14&P2 Installation Kit for Electronic Equipment MK1815/GRC-106 and Difference Kit in Truck, 1½-Ton

11-2300-459-14&P5 Installation Kit for Electronic Equipment MK1817/VRC-46 and Difference Kit in Truck, 1½-Ton

11-4134 Manual Telephone Switchboard SB-86/P; Field Maintenance

11-5038 Control Group, AN/GRA-6

11-5543 Radiac Sets, AN/PDR-27A, AN/PDR-27C and AN/PDR-27E (Encl RPSTL)

11-5805-201-12 Telephone Set (TA-312/PT)

11-5805-262-12 Operator's and Organizational Maintenance Manual, Switchboards, Telephone, Manual SB-22PT and SB-22A/PT

(O)11-5810-256-12 Speech Security Equipment TSEC/KY-57

(O)11-5810-256-OP1 Operator's Card for Speech Security Equipment TSEC/KY-57: Net Controller Operating Procedures for Communications Security Equipment

A-7. Technical Manuals (TM) (Continued):

11-5810-256-OP3	Operator's Card for Speech Security Equipment TSEC/KY-57: For Use in Wheeled Vehicles
11-5810-256-OP5	Operator's Card for Speech Security Equipment TSEC/KY-57: Retransmission
11-5810-256-OP6	Operator's Card for Speech Security Equipment TSEC/KY-57; FM Secure Remote Communications
11-5810-256-OP7	Operator's Card for Speech Security Equipment TSEC/KY-57: Point-to-Point Communication
11-5810-312-12-1	TSEC/KY-57: Installation Kits (Volume 1)
11-5810-312-12-4	TSEC/KY-57: Installation Kits (Volume 4)
11-5815-334-12	Operator's and Organizational Maintenance Manual (Including Repair Parts and Special Tools List) Radio Teletypesriter Sets
11-5820-401-10-1-HR	Hand Receipt Manual Covering Radio Sets
11-5820-401-10-LD-5	Plastic Laminated Condensed Operating Instruc- tions for Radio Set AN/VRC-46
11-5820-401-10-LD-6	Plastic Laminated Condensed Operating Instruc- tions for Radio Set AN/VRC-47
11-5820-401-10-2	Radio Sets
11-5820-401-10-2-HR	Hand Receipt Manual Covering Radio Sets
11-5820-401-12	Radio Sets (Encl RPSTL)
11-5820-610-14	Operator's Organizational Direct Support and General Support, Maintenance Manual: Radio Terminal Set AN/TRC-133A
11-5895-262-14	Antenna AS/1729/VRC
11-5985-357-13	Antenna Group OE-254/GRC
11-6130-266-15	Power Supply PP 6224/U and PP 6224A/U (Encl RPSTL)
11-6625-203-12	Multimeter AN/URM-105 and AN/URM-105C
11-6665-214-10	Operator's Manual: Radiacmeter IM9E/PD, IM93/UD, IM-93A/US, and IM-147/PD

A-7. Technical Manuals (TM) (Continued):

38-122-15-2 Functional User's Manual for Division Logistics System (DLOGS): Class IX (Repair Parts) Supply System Supply Operating Procedures: Using Unit Procedures

(C)39-50-8 Emergency Destruction of Nuclear Weapons (U)

39-100-4 Custody Accountability and Control of Nuclear Weapons and Nuclear Materiel

A-8. Joint Chiefs of Staff Publications (JCS Pub):

(S)JCS Pub 13 Vol 1 Policy and Procedures Governing the Authentication and Safeguarding of Nuclear Control Orders (U)

(S)JCS Pub 13 Vol 2 Policy and Procedures Governing the Permissive Action Link/Coded Switch Cipher System (U)

A-9. Allied Communications Publications (ACP):

117 Allied Routing Indicator Book

121 Communications Instructions-General Air/Ground

125(D) Communications Instructions Radiotelephone Procedures

126 Communications Instructions Teletypewriter (Teleprinter) Procedures

131 Communications Instructions--Operating Signals

134 Telephone Switchboard Operating Procedures

A-10. Army Training and Evaluation Programs (ARTEP):

6-625 Pershing II Field Artillery Battalion

A-11. Training Circulars (TC):

3-1 How to Conduct NBC Defense Training

6-15E1/2(JB) Pershing Missile Crewmember Job Book, 15E (Skill Level 1/2)

6-21G1/2(JB) Pershing Electronics Materiel Specialist Job Book, 21B (Skill Level 1/2)

A-11. Training Circulars (TC) (Continued):

6-82C1/2(JB)	Field Artillery Surveyor Job Book 82C (Skill Level 1/2)
8-3	Field Sanitation Team Training
10-2	Petroleum Terms, References and Abbreviations
11-4	Handbook for AN/VRC-12 Series of Radio Sets
16-25	Ministry in a Combat Environment
19-16	Countering Terrorism on US Army Installations
21-3	Soldier's Handbook for Individual Operations in Cold Weather Areas
23-13	Crew Served Weapon Night Vision Sight
(0)24-1	Communications-Electronics Operation Instructions, The CEOI
24-18	Communications in a "Come As You Are" War
27-1	Your Conduct in Combat Under the Law of War
30-22	Battlefield Survival and Radio-Electronic Combat
32-05-PT	Electronic Counter-Countermeasures (ECCM): Procedures for the Communicator
32-11	How to Get Out of a Jam

A-12. Tables of Organization and Equipment (TOE):

06-600-J300	FA Bde, Pershing
06-625-J300	FA Bn, Pershing II
06-626-J300	HH & SB, FA Bn Pershing
06-627-J300	FA Battery, Pershing
07-015-H	Infantry Battalion, Pershing
63-075-J	Maintenance Battalion, Pershing

A-13. Applications NATO Standardization Agreements (STANAGs)/ABCA
(Quadripartite) Standardization (QSTAGs):

2008	Bombing, Shelling, Mortaring, and Location Report
2020	Operational Situation Reports
2024	Military Vehicle Lighting
2047	Emergency Alarms of Hazard or Attack (NBC and Air Attack Only)
2070	Emergency War Burial Procedures
2083	Commander's Guide on Radiation Exposure
2101	Principles and Procedures for Establishing Liaison
2103	Reporting Nuclear Detonations, Radioactive Fallout, and Biological and Chemical Attacks and Predicting, Associated Hazards
2104	Friendly Nuclear Strike Warning to Armed Forces Operating on Land
2112	Radiological Survey
2113	Destruction of Military Technical Equipment
2126	First Aid Kits and Emergency Medical Care Kits
2150	NATO Standards of Proficiency for NBC Defense
2154	Regulations for Military Motor Vehicles
2225	Technical Data for Handling Nuclear Weapons
2358	NBC Hygiene, First Aid and Hygiene Training in NBC Operations
3117	Aircraft Marshalling Signals

STANAGs and QSTAGs can be obtained from Naval Publications Center, 5801 Tabor Avenue, Philadelphia, PA 19120. DD Form 1425 may be used to requisition documents.

A-16. Graphic Training Aid (GTA):

3-6-2

NBC Warning and Reporting System

A-17. Miscellaneous:

Manual for Courts Martial (MCM) (UCMJ)

APPENDIX B RANGE CARD

Normally, a soldier prepares a range card while preparing his defensive position. He should complete the range card, except the data section, before constructing the parapet and digging in. This permits the completion of defensive planning as soon as possible. He completes the data section after the fighting position is constructed and the weapon is set in place.

B-1. PREPARATION OF THE RANGE CARD

The following procedures should be followed when preparing a range card:

- a. Orient the card (use anything on which you can write, such as a C-ration box top) so both the primary and secondary (if assigned) sectors can be drawn.
- b. Draw a rough sketch of the terrain to the front of the position. Include prominent natural and man-made features that could be likely targets, and center the position at the bottom of the sketch.
- c. Fill in the marginal data to include--
 - (1) Gun number.
 - (2) Unit designation.
 - (3) Date.
 - (4) Magnetic north arrow.
- d. Use a compass to determine magnetic north, and sketch in the basic symbol (fig B-1) on the card with its base starting at the top of the marginal data section.

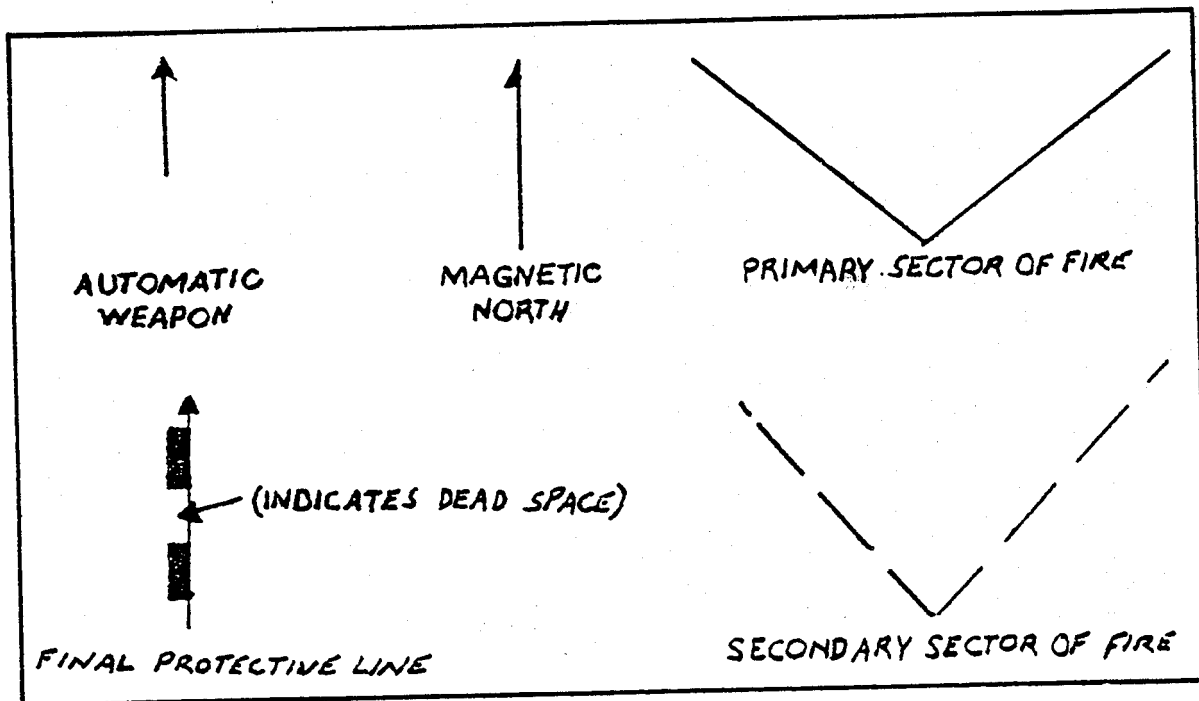

Figure B-1. Symbols.

e. Specify the location of the gun position in relation to a prominent terrain feature. When no such feature exists, place the eight-digit map coordinates of the position near the point on your sketch representing the position (fig B-1). If there is a prominent terrain feature within 1,000 meters of the gun, use that feature (fig B-2).

(1) Using a compass, determine the azimuth in mils from the terrain feature to the gun position.

(2) Determine the distance between the gun and the feature. This can be done by pacing or using a map.

(3) Sketch in the terrain feature on the card, and identify it.

(4) Connect the sketch of the position and the terrain feature with a barbed line from the feature to the gun (fig B-3).

(5) Write in the distance in meters (above the line) and write in the azimuth in mils from the feature to the gun (below the line) (fig B-3).

f. Sketch in the primary sector of fire with a principal direction of fire (PDF) or a final protective line (FPL).

(1) Primary sector with principle direction of fire.

(a) Sketch in the limits of the primary sector of fire as assigned (fig B-2). The sector should not exceed 875 mils (the maximum traverse of the tripod mounted M60).

(b) Sketch in the symbol for an automatic weapon oriented on the most dangerous target within your sector.

(2) Primary sector with final protective line.

(a) Sketch in the FPL as assigned (fig B-3). Have someone walk the FPL and determine dead space (sections of the FPL where an individual's waist level is below the line of sight).

(b) Reflect dead space on the sketch by a break in the symbol for an FPL, and write in the range to the beginning and end of the dead space.

(c) Write in the maximum range of grazing fire (600 meters for an M60 machine gun if not obstructed at a closer range).

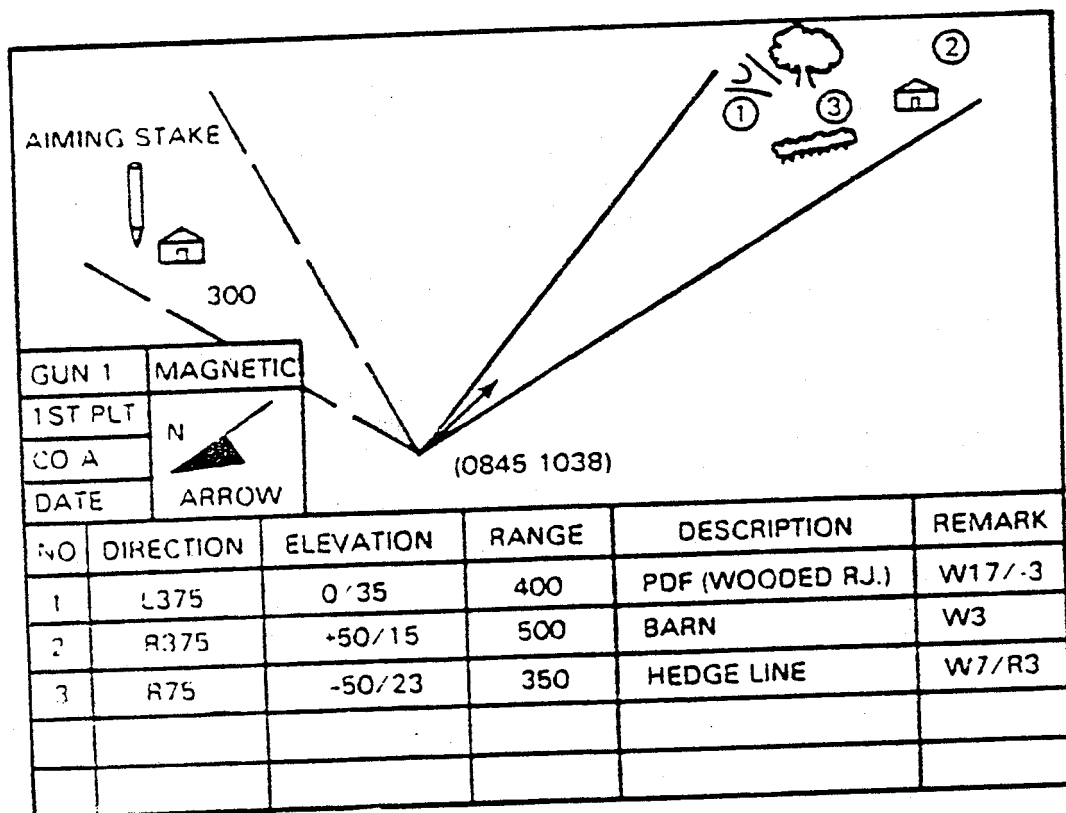

Figure B-2. Range card with principal direction of fire.

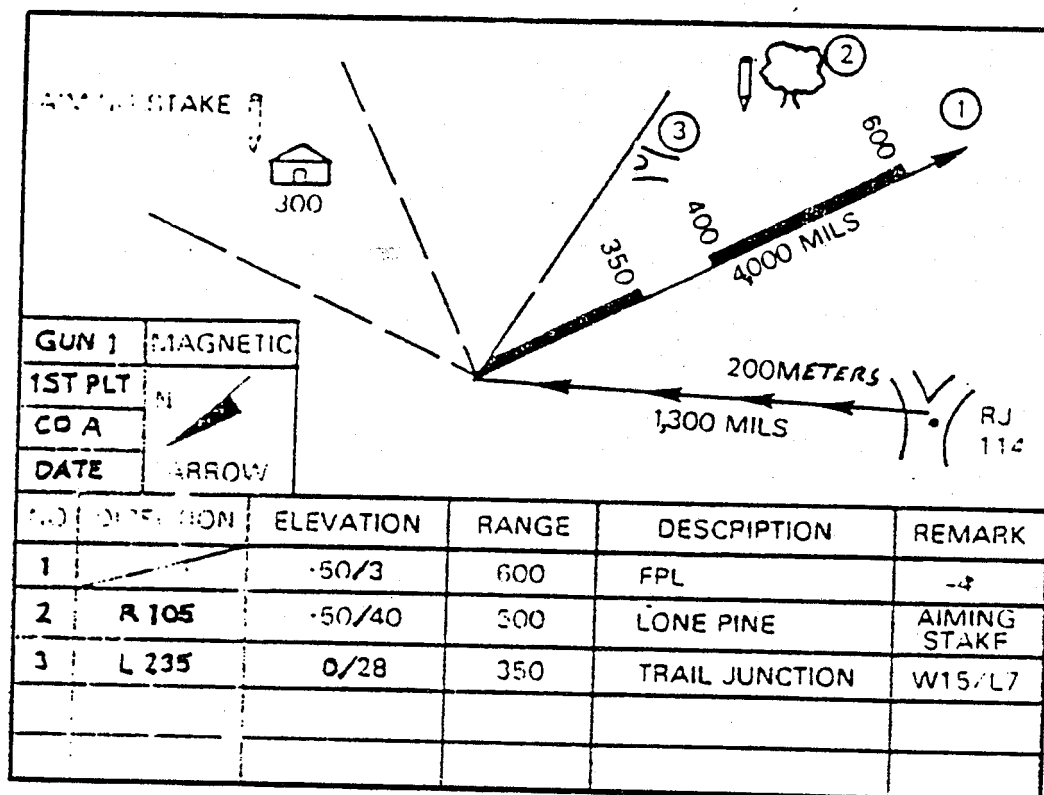

Figure B-3. Range card with final protective line.

g. Label the targets in the primary sector in order of priority. Label the FPL or PDF.

h. Sketch in the secondary sector of fire (as assigned), and label targets within the secondary sector with the range (in meters) from the gun to each.

Note. The tripod restricts fire to the primary sector and once emplaced, it should not be moved. The bipod is used when firing into the secondary sector. Sketch in aiming stakes if they are used.

B-2. PREPARATION OF THE DATA SECTION

The tripod and Traverse and Elevating (T&E) mechanism are used only by the M60 machine gun crew. Use of the T&E mechanism allows the delivery of accurate fires during periods of limited visibility. Reference material concerning the T&E mechanism is in FM 7-11B1/2 and FM 23-67.

B-2. USE OF THE RANGE CARD FOR THE M16A1 and M203

The range card for the M16A1 and M203 is used in conjunction with aiming posts and elbow rests in the fighting position to provide rough alignment of the weapon with the desired target. There is currently no method available for tabulation of target data for these weapons.

APPENDIX C
DEFENSE DIAGRAM

The defense diagram is a sketch, drawn to scale, of the platoon defensive resources. It is based on the data from each terrain sketch and range card and includes the fields of fire for weapons such as M60 machine guns, grenade launchers, and individual weapons. Equipment required includes 1:50,000 map of the area, a coordinate scale, a protractor, overlay paper, and a blank 1:25,000 grid sheet.

C-1. CONSTRUCTION OF THE MATRIX

a. Locate the platoon center on the 1:50,000 map. Identify the grid square or squares that contain the terrain features that influence the defense of the platoon position.

b. Place tick marks at 200-meter intervals along the sides of the selected grid squares (fig C-1).

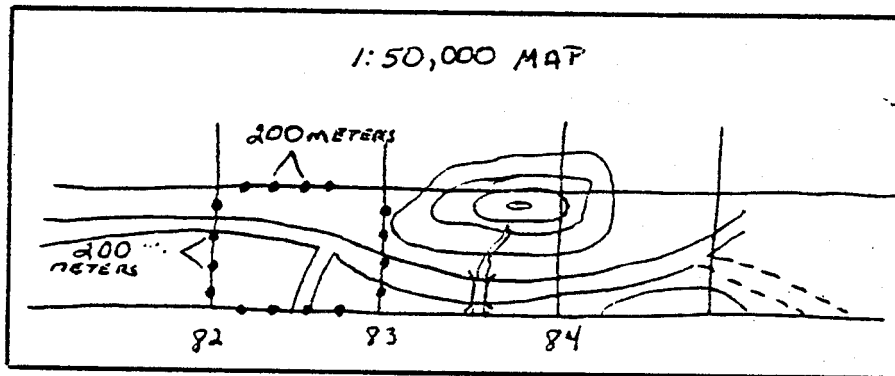

Figure C-1. Tick-marking the grid square.

c. Connect the tick marks to form 200 by 200 meter squares within each grid square (fig C-2).

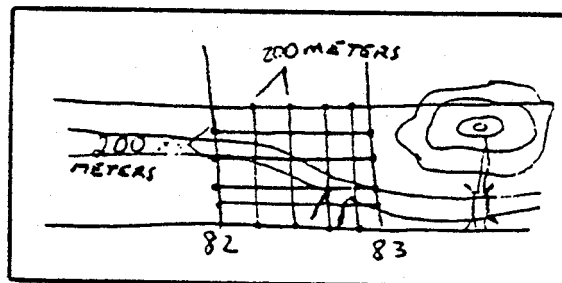

Figure C-2. Forming the matrix.

d. Label the squares beginning at the lower left of the grid square.

Number the lines to the right and up, as you would read a map (fig C-3).

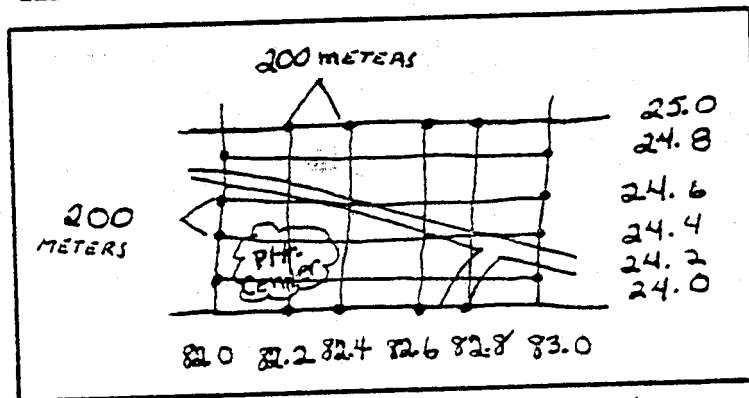

Figure C-3. Labeling the matrix.

e. Expand the scale to 1:50,000 by using a blank 1:25,000 grid sheet. In expanding the scale to 1:50,000, each 200- by 200-meter block within the matrix correlates with a 1,000-meter grid square on the 1:25,000 grid sheet. Determine which 200 by 200 meter block on the matrix contains the platoon center. In figure C-3 it is 82.2 24.4. Next, select a square near the center of the blank grid sheet, and label this square the same--82.2 24.4. You have identified and labeled the 200 by 200 meter block where the platoon center is located. From that point, duplicate the labeling from the matrix on the grid sheet.

f. Examine the 200 by 200 meter blocks on the 1:50,000 map that contain key terrain features that influence the defense. Sketch what you visualize in these blocks on the corresponding squares of the 1:50,000-scale grid sheet. The result is a map reproduction minus the contour lines and other data not pertinent to the defense of the battery (fig C-4). However, contour lines representing hills or depressions may be included if they are deemed pertinent.

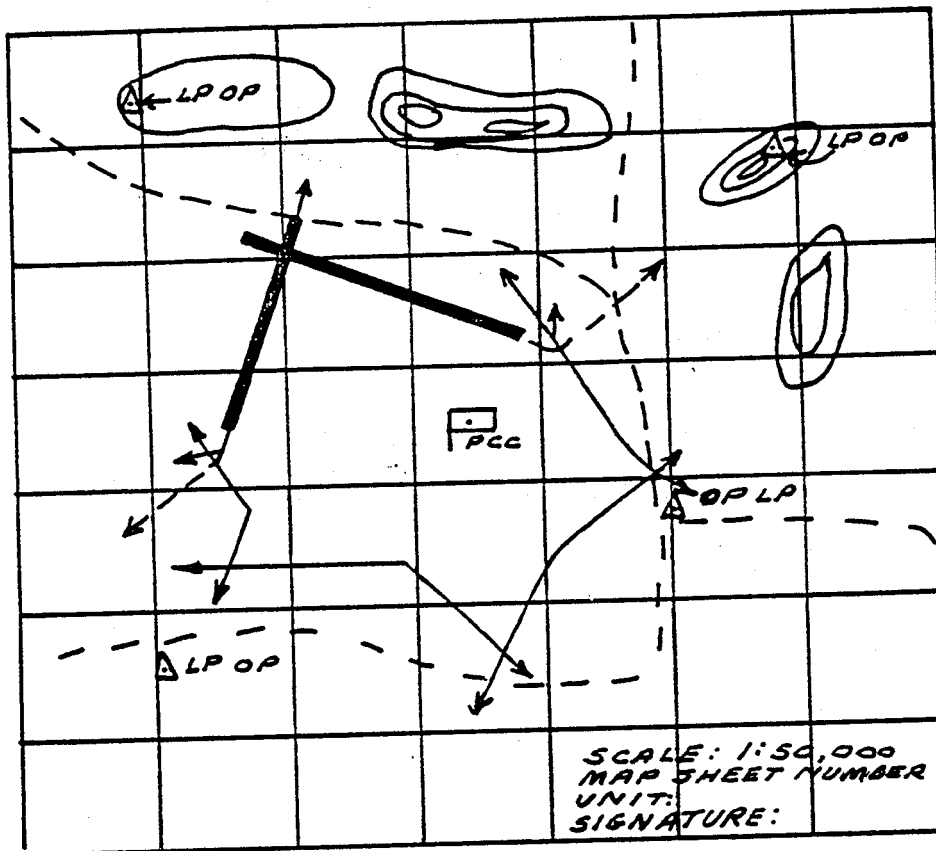

Figure C-4. Sketching key terrain.

C-2. PLOTTING ON THE DIAGRAM

Use a 1:50,000 coordinate scale to plot coordinates and to measure distance on the 1:50,000-scale grid sheet by dividing the indicated graduations on the coordinate scale by 10; e.g., the 1,000-meter graduation is read as 100 meters. Use the protractor for measuring azimuths or directions.

a. Plot the weapon locations and sectors of fire. The following sources are available to assist in this task:

- (1) Machine gun range cards indicate the location and the azimuths of the left and right limits and/or final protective line.
- (2) Individual weapon terrain sketches also may be used to plot areas of coverage.

b. In all cases, plot locations within 10 meters and directions within 10 mils. On the diagram, indicate the actual location of a weapon by the base of the stem of the weapon symbol. See FM 21-30 for symbols.

C-3. AVAILABLE RESOURCES

There are many resources available to the battery for its defense. The defense diagram should show where each asset is located. The following is a list of some of the resources which may be available to the battery. Each platoon leader should check the basic load of ammunition he is authorized and the battery's field SOP for his share of the battery's assets.

a. Observation devices that may be allocated to a firing battery include:

- o Binoculars 20 each
- o Night Vision Goggles (AN/PVS-5) 18 each
- o Night Vision Sight, individual served weapon (AN/PVS-4) 8 each

b. Weapons that may be allocated to a firing battery include:

- o Pistol, Caliber .45 4 each
- o Rifle, 5.56-mm (M16A1) 192 each
- o Grenade Launcher, 40-mm (M203) 17 each
- o Machine Gun, 7.62-mm (M60) 16 each
- o LAW (M72A2) 30 each
- o Mine, Antipersonnel 18 each
- o Grenade, Fragmentation 108 each
- o Grenade, Smoke 80 each

APPENDIX D
NUCLEAR, BIOLOGICAL, CHEMICAL DEFENSE

D-1. UNIT NBC DEFENSE

All unit leaders must thoroughly understand the implications of the NBC environment and be prepared to deal with problems as they arise. The NBC defense teams must be well trained to help prepare the unit for operations in an NBC environment. Individuals must be proficient in basic NBC survival skills. The following special teams, with their inherent functions, will help the battery commander establish a sound unit NBC defense.

a. Battery NBC control cell. The NBC control cell, organized under the NBC NCO, advises and helps the commander on prestrike and poststrike NBC defense matters.

(1) Prestrike responsibilities are:

(a) Train the survey/monitoring and unit decontamination teams.

(b) Train chemical detection teams and operators of chemical agent alarms.

(c) Train unit supervisors who, in turn, train the troops.

(d) Ensure that unit NBC equipment is of sufficient quantity, maintained in proper condition, and adequately distributed.

(e) Ensure that the unit has a functional, recognizable NBC alarm system in consonance with the applicable STANAG/QSTAG (app G).

(f) Advise the battery commander on Mission-Oriented Protective Posture (MOPP).

(g) Have available the most current nuclear and chemical downwind messages to predict future NBC hazard areas. Meteorological data is obtained from organic equipment or from higher headquarters.

(2) Post strike responsibilities are:

(a) Supervise survey/monitoring and unit decontamination team operations.

(b) Make a simplified fallout prediction.

(c) Draw a detailed fallout prediction.

(d) Draw a chemical downwind hazard prediction.

(e) Send and receive messages and act on NBC 1 through 6 reports.

(f) Maintain radiation status of the battery by platoon.

(g) Advise the battery commander on where, when, how and if the unit should move.

b. Platoon NBC control cells. Because of their independent locations, each platoon area should have an enlisted alternate to the NBC NCO. This person should be able to do the same tasks as the battery NBC cell. Normally, he will be a member of a light platoon trained by the battery NBC NCO.

c. NBC special teams. These teams include the survey/monitoring team for each platoon area and the battery decontamination team. These teams are trained by the NBC officer and NCO. There should be a senior member on each team to act as team chief to immediately supervise their operations.

(1) Radiological survey/monitoring teams. The radiological survey/monitoring teams are responsible for nuclear environmental sampling of positions that are occupied, or are to be occupied, by battery units. In each area there should be a primary team consisting of two trained personnel for each piece of detection or monitoring equipment (IM-93, AN/PDR-27, IM-174). There should be an alternate team for each type of equipment.

(2) Chemical detection teams. These teams are responsible for environmental sampling to ensure the unit is not exposed to chemical hazards. The requirements for chemical agent detector operators are the same as those for the radiological detection/monitoring equipment (M256 kit, M8 alarm, M8/M9 paper).

(3) Decontamination teams. The battery will also have a decontamination team. This team should be made up of a minimum of 10 personnel. They will set up partial decontamination points, help crews in decontamination operations, and help at battalion decontamination points when necessary.

D-2. CHEMICAL DEFENSE EQUIPMENT

a. Individual equipment.

(1) Each soldier should have at least two complete sets of chemical protective clothing, to include the chemical protective overgarment, protective boots, and rubber gloves.

(2) One protective mask with hood is issued to each soldier. This, with the chemical protective clothing, affords complete chemical protection. Maintenance of the mask, to include changing of filters, is the responsibility of the individual.

(3) There should be two M258A1 skin decontamination kits per individual. The M58A1 training kit can be used to train soldiers on use of the skin decontamination kits.

(4) Other items for individual chemical protection include M8 Detector Paper, Mark I injector, and M1 Canteen Cap. FM 3-4 discusses use of these items. Local commanders will establish issuing policies for chemical agent antidotes.

(5) The M256 chemical detection kit is issued to the unit's NCOs, officers, and chemical detection team members. When and where these kits are used is covered in SOPs and the defense plan.

b. Unit equipment.

(1) Normally, there is one M11 decontamination apparatus issued per vehicle and one per crew-served weapon. It is used to spray a liquid decontaminant (DS-2) in partial decontamination. The spray is applied on only those areas that the operator makes contact with during operation. A more thorough decontamination will be performed as soon as time and situation permit.

(2) The Chemical/Biological (CB) Protection System in the PCC and RSGF protects personnel from CB agents. A CB filter cleans CB agents and dust from the air and provides a positive pressure inside the shelter. The M14 CB Protective Entrance uses a 5-minute air bath to cleanse personnel of vapors. Personnel must be decontaminated before entering the shelter. A control module for the protective entrance is located inside the shelter. The M43 Chemical Agent Detector monitors the air inside the shelter. If contaminants are detected, the M42 Chemical Agent Alarm provides a visible/audible warning signal to personnel inside the shelter.

(3) M8 Alarms, consisting of M43 Chemical Agent Detectors, M42 Chemical Agent Alarms, and other ancillary equipment will be positioned by the unit's NBC team around the position area and on vehicles during convoys. These alarms detect small concentrations of CB agents and warn personnel to assume MOPP level 4. Use of these alarms is covered in FM 3-5, TC 3-3, and TM 3-6665-225-12.

D-3. NBC OPERATIONS

a. Chemical attack.

(1) Nonpersistent agents dissipate within a few hours. If the agent is present in liquid form, the unit must perform partial decontamination as soon as possible to minimize further spread of the contamination.

(2) Units exposed to persistent agents should be directed to move by the battalion operations center as soon as the mission and tactical situation permit. The unit must immediately go through a

decontamination point and undergo complete decontamination of vehicles, equipment, and personnel. Speed and thoroughness are paramount to survivability under these conditions. The unit must have all personnel and equipment decontaminated within 6 hours, which is the limit of effectiveness for the protective clothing. Decontamination operations are discussed in detail in FM 3-5. Personnel and mission-essential equipment should be taken immediately to the decontamination point. Tents, camouflage nets, concertina and communications wire, etc., are left in the affected area. If time becomes critical, the unit decontamination team may perform partial equipment decontamination as described in FM 3-5.

(3) As a minimum, when chemical agents are detected in an area, the following actions must take place.

- (a) Immediately assume MOPP level 4 and sound alarm.
- (b) Submit NBC 1 (chemical) Report to battalion headquarters by fastest means possible.
- (c) Use survey/monitoring teams (if not already employed) to detect type, extent, and duration of contamination.
- (d) Request assistance and permission to move if necessary.

(4) Because of the quick action of modern chemical agent effects, each individual is responsible for emergency decontamination when he knows or suspects that his skin or personal equipment has become contaminated. Individual decontamination measures are described in FM 3-5.

b. Nuclear attack. If there is a nuclear attack, the unit should immediately implement individual and unit protective measures. Individual perimeter positions, LPs, and OPs should be well dug in. Nuclear fallout may not necessitate a unit movement. If a nuclear blast is observed, the following actions should be taken:

- (1) Take cover. Deep foxholes with overhead cover provide the best protection.
- (2) Prepare and send an NBC 1 (nuclear) Report in accordance with local policy.
- (3) Prepare a simplified fallout prediction.
- (4) Begin continuous radiation monitoring.
- (5) If radiation is detected, record total dosage received.

(6) Remember the following rad tolerances:

(a) 70 rads/cGy--request, through battalion, permission to move.

(b) 150 rads/cGy--radiation sickness can be expected in approximately 5 percent of the unit within 6 hours.

(c) 350 rads/cGy or more--there will be deaths within a few days.

(d) 650 rads/cGy--100 percent of unit will be combat ineffective within 2 hours; over half will die after approximately 16 days.

(7) Decontaminate equipment and personnel as soon as possible.

D-4. NBC REPORTING

NBC reporting procedures are discussed in detail in FM 21-40. As a minimum, all senior personnel must be able to prepare and transmit the required reports.

D-5. SAMPLE SOP

The following is a portion of an SOP for NBC operations. It may be used as a guideline in developing the unit's NBC SOP/field SOP.

(6) Remember the following rad tolerances:

(a) 70 rads/cGy--request, through battalion, permission to move.

(b) 150 rads/cGy--radiation sickness can be expected in approximately 5 percent of the unit within 6 hours.

(c) 350 rads/cGy or more--there will be deaths within a few days.

(d) 650 rads/cGy--100 percent of unit will be combat ineffective within 2 hours; over half will die after approximately 16 days.

(7) Decontaminate equipment and personnel as soon as possible.

D-4. NBC REPORTING

NBC reporting procedures are discussed in detail in FM 21-40. As a minimum, all senior personnel must be able to prepare and transmit the required reports.

D-5. SAMPLE SOP

The following is a portion of an SOP for NBC operations. It may be used as a guideline in developing the unit's NBC SOP/field SOP.

APPENDIX 1 (NBC Decontamination) to Annex F (Action to Reduce Effects of Enemy Chemical and Biological (CB) Attack) to X Battery Field SOP

1. PURPOSE: To outline policy and procedures for personnel and equipment decontamination in X Battery.

2. DEFINITIONS: There are three types of decontamination. Each is described below.

a. Emergency decontamination is performed by the individual to neutralize and/or remove contaminants from the body. Emergency decontamination must be performed within one minute after contamination in order for the individual to survive.

b. Partial decontamination is performed by unit decontamination teams to remove gross amounts of NBC contamination from weapons, combat vehicles, individual equipment and other mission-essential equipment. Contaminated personnel remove CB contaminants using personal decontamination kits and portable decontamination apparatuses assigned to vehicles. Radiological contamination is removed by brushing, sweeping or shaking away dust and debris. When time is critical, assistance may be provided by the supporting decontamination unit. Partial decontamination is performed within one hour of contamination and external to the contaminated position.

c. Complete personnel and equipment decontamination is performed by the chemical detachment with major support from the supported unit. This type of decontamination reduces the NBC contamination hazard to a level which allows soldiers to operate at a lower mission oriented protective posture. For chemical decontamination in X Battery, personnel showers will not be given since the M12A1 PDDAs will be dedicated to equipment decontamination. Personnel will discard contaminated clothing and equipment using fixed undressing procedures and then move to the redressing area for issue of clean clothing. Personnel with skin contamination will use the M258A1 Skin Decontamination Kit to effect agent removal and decontamination. Showers will be provided when radiological contamination is involved.

3. RESPONSIBILITIES

a. Battery and company commanders are responsible for appointing and training a decontamination team and supporting the chemical detachment in performing complete personnel and equipment decontamination.

b. The chemical detachment provides support level decontamination for X Battery and, as necessary, assists units in performing partial decontamination.

4. EXECUTION: Complete personnel and equipment decontamination is a major undertaking and must be carefully planned, coordinated and executed.

a. Pre-decontamination activities.

(1) A suitable decontamination site should be jointly selected by the supported unit and the supporting decontamination section. Characteristics of a good decontamination site are: extensive road network trafficable by all equipment and vehicles to be supported; allows water resupply without contact with contaminated equipment; good overhead cover and concealment; adequate water source; capable of being secured; good drainage for runoff; located on a paved road or hardstand and outside the threat area. Unit commanders will make final determination of location of the decontamination station. Every effort should be made to preselect the site to ensure sufficient time is available to select a site which meets the needs of both the contaminated unit and the supporting chemical detachment. Time is also a critical factor in decontamination operations since the life cycle of the chemical protective suit is six hours in a contaminated environment.

(2) Identify the chemical agent employed on your position.

(3) Perform emergency and partial (hasty) decontamination.

(4) Perform damage control assessment.

(5) Dispatch medical personnel and unit decontamination team to assist in setup and operation of the decontamination station. A minimum of twelve soldiers is needed to assist the chemical detachment. Duties will be: operate hot soapy water wash, DS2 application, final rinse, transport personal equipment to redress area, and decontaminate protective masks and other individual equipment.

(6) Transport squad boxes or laundry bags to decontamination station.

(7) Emplace contamination markers at contaminated site.

(8) March order unit according to decontamination priority. Brigade decontamination priorities are:

(a) Command and control personnel and equipment.

(b) Missile equipment and crews.

(c) Missile support equipment and personnel.

(d) All other.

b. Actions required at the decontamination site are:

(1) On arrival at the decontamination site, the supported unit will maintain command and control of all personnel and equipment to be decontaminated, provide site security (includes security of primary weapon system), perform traffic control, provide towels, soap, etc.

(2) The chemical detachment will brief key unit personnel on the layout and operation of the decontamination station, call up vehicles, equipment and personnel for movement through the decontamination station and direct activities at critical points at the station.

(3) Unit will process through each point of the decontamination station IAW procedures outlined by the chemical detachment. See Tab A and Tab B.

(4) Key concerns at this point are:

(a) Clean and contaminated areas are clearly marked and observed.

(b) Once decontaminated, neither personnel nor equipment should be allowed to reenter the contaminated area of the decontamination station.

(c) No short cuts are taken since this will endanger the lives of unit personnel and degrade mission capability of the unit.

(d) Provisions have been made for mess, maintenance of equipment and medical attention.

c. Post decontamination activities (the chemical detachment).

(1) Dispose of contaminated clothing and equipment (when possible, place contaminated clothing and equipment in a pit, cover with layer of STB and bury).

(2) Decontaminate detachment personnel and supported unit decontamination team.

(3) Mark area with appropriate contamination markers.

(4) Effect coordination for resupply of DS2, STB, etc.

(5) Coordinate with controlling battalion for providing personnel showers as time permits.

(6) Continue the mission.

Tab B (Equipment Decontamination Station) to Annex F (Actions to Reduce Effects of Enemy Chemical and Biological (CB) Attack) to X Battery Field SOP

1. PURPOSE: To outline procedures for processing through an equipment decontamination station.

2. PROCEDURES:

a. STEP 1. Enter site from downwind direction; spray vehicle with hot soapy water. This includes undercarriage and running gears.

b. STEP 2. Move vehicle to DS2 application station; apply DS2. Scrubbing may be required to remove thickened chemical agents.

c. STEP 3. Move equipment to holding area for 30 minute contact time.

d. STEP 4. Clean interior of vehicle with hot soapy water.

e. STEP 5. Rinse DS2 and hot soapy water from vehicle and move to agent check station.

f. STEP 6. Check equipment with M256 kit and M8 paper for presence of contamination (use AN/PDR-27 radiac set to check for radiological contamination). If contamination is detected, recycle equipment through decontamination station.

g. STEP 7. Move to maintenance support area to dry and oil equipment. This is essential since decontaminant DS2 is corrosive to metals and softens rubber components.

h. STEP 8. Move to assembly area and link up with personnel.

Tab A (Personnel Decontamination Station) to Annex F (Actions to Reduce Effects of Enemy Chemical and Biological (CB) Attack) to X Battery Field SOP

1. PURPOSE: To outline procedures for processing through a personnel decontamination station (PDS).
2. PROCEDURES:
 - a. STEP 1. Contaminated soldiers enter PDS from downwind direction, decontaminate combat gear (weapon, web gear and harness, etc) by submerging it in a solution of STB and water. Once this is completed, clean soldiers move combat gear to assembly area at the other end of the PDS.
 - b. STEP 2. Two soldiers move to STB station and wash gross contamination from gloves and overshoes; wash gloves with hot soapy water; wash mask and hood with hot soapy water.
 - c. STEP 3. Discard overshoes; scrub gloves and boots with hot soapy water and rinse.
 - d. STEP 4. Remove combat boots and pass to members of supported unit who transport them to the clean assembly area.
 - e. STEP 5. Remove protective overgarment and place in designated container.
 - f. STEP 6. Remove gloves and place in container.
 - g. STEP 7. Place personal effects (rings, watches, wallets, etc) in plastic bags provided by the chemical detachment. Bags are identified by soldier's dog tags and transported to clean assembly area.
 - h. STEP 8. Remove fatigues/BDUs. (Note: In training exercises, this step will be conducted in an undressing tent; male and female soldiers will process separately.) In combat, male and female soldiers will be processed without regard to gender when gross contamination is involved.
 - i. STEP 9. Remove underwear and place in container.
 - j. STEP 10. Take a deep breath, remove mask, rinse, and pass to attendant.
 - (1) Supported unit removes filter elements and hoods from protective masks; wipe mask with hot soapy water using a damp sponge; wipe mask with clear water using a damp sponge.
 - (2) For nuclear contamination, soldiers receive showers and are monitored for contamination. If contamination is found, soldiers are returned to the shower point and then rechecked.

k. STEP 11. Move to clothing exchange facility.

l. STEP 12. Redress, claim weapon, combat boots, personal effects and move to personnel assembly area. Soldier's requiring medical attention move to the medical aid station.

APPENDIX E TRAINING FOR A FIELD ENVIRONMENT

To survive in combat, a unit must train to fight and must continue this training throughout all field exercises and maneuvers. Under the Army training philosophy, the authority and responsibility to organize, conduct, evaluate, and supervise training is delegated through the battalion to the battery level. Decentralized training focuses all training effort at or below the battery level, where the job is actually performed. Therefore, it is the battery commander's responsibility to provide specific instructions to subordinate officers and NCOs to help them prepare and conduct training. Battery officers and NCOs must constantly provide feedback to the battery commander on the battery's training needs and levels of proficiency. See FM 21-6 for guidelines on formulating training.

E-1. PERFORMANCE-ORIENTED TRAINING

Performance-oriented training concentrates on those critical tasks that prepare soldiers for combat. Training is structured around performance-oriented training objectives that contain a statement of the task to be performed, the conditions under which the task is performed, and the training standards of acceptable performance. Because of their nature and structure, these objectives facilitate clear and concise thinking about training for combat.

E-2. DEVELOPING THE TRAINING PROGRAM

FM 25-2 (Test) has been written specifically for training managers. It describes a four-step process to develop training programs (see fig E-1). This publication should be used in conjunction with the Army Training and Evaluation Program (ARTEP) 6-625, The Field Artillery Battalion, Pershing and applicable soldiers manuals.

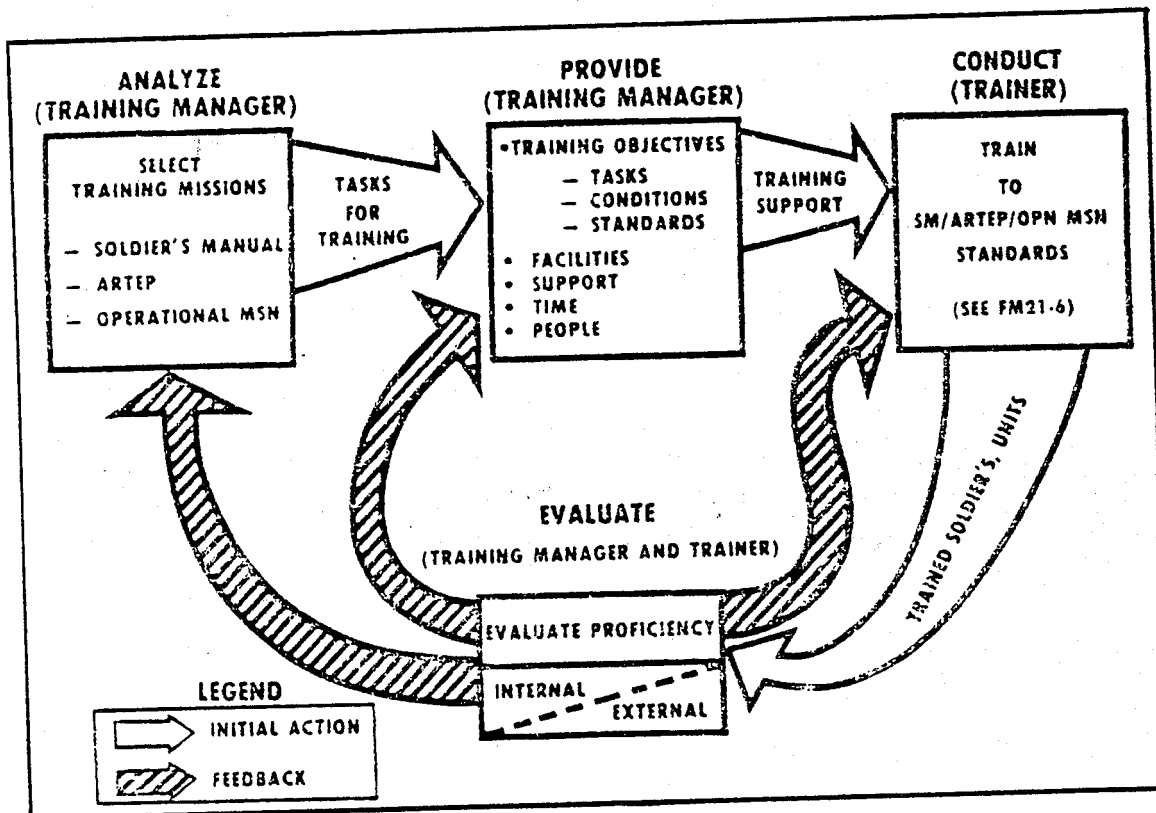

Figure E-1. The four-step training process.

a. Training program analysis. In program analysis, the battery commander must determine:

- (1) The current training level.
- (2) The desired training level.
- (3) The means to achieve the desired training level.

ARTEP and SQT standards and results can be used to obtain this information.

b. Provision of tools. Once the battery commander has completed his program analysis, he determines what tools will best fulfill the training needs.

c. Conduct. The battery commander then programs the training. It will not be possible to select all the performance objectives that were determined in the analysis phase. The BC should focus on those objectives that make the greatest contribution to accomplishment of the unit's mission. He must ensure that qualified personnel conduct the training.

d. Evaluation. Performance-oriented training objectives have a built-in evaluation, which shows whether the task has been done to the standards under the given conditions. Thus, the BC can decide whether his unit has reached his training goals. If not, he starts the training cycle again with input from the evaluation. If so, he orients training toward a new goal.

E-3. TRAINING MANAGEMENT

Training management is a continuous process. At battery level, it depends on trial and error to match what the commander wants to do with what the unit has time and resources to do. The object is to build and sustain readiness in the unit to perform its mission.

E-4. TRAINING PUBLICATIONS

The following is a list of those key training publications that form the basis for any battery training program. These publications must be understood and used by all supervisors involved with training or training management.

- a. The Army Training and Evaluation Program for the unit (ARTEP 6-625).
- b. The soldier's manuals and commander's manuals for all MOSs in the unit.
- c. The operator's manual for each piece of equipment in the unit.
- d. The applicable technical manuals for the Pershing II system.
- e. FM 6-11, The Pershing II Firing Battery.
- f. FM 21-6, How to Prepare and Conduct Military Training.
- g. FM 25-2, Training Management in Battalions.

E-5. ARMY TRAINING AND EVALUATION PROGRAM AND FIELD TRAINING EXERCISE

a. The Army Training and Evaluation Program (ARTEP) is designed to assess the unit's ability to--

- (1) Execute its full wartime mission tasking.

(2) Accomplish that mission over a sustained period as a mobile force.

b. The ARTEP evaluation criteria fall into the following areas:

(1) Operations--an assessment of the unit's ability to perform its wartime mission on a sustained basis as a mobile force. This includes attaining and maintaining target coverage, displacing to maintain survivability, and firing simulated missions.

(2) Support--an assessment of the unit's capability to use available support resources efficiently in sustained operations. The assessment includes command and control, management, plans, procedures, and proficiency of support personnel. Field maintenance, the execution of preventive maintenance, the capability of supply and maintenance personnel to react to equipment breakdowns, and resupply procedures are also assessed.

(3) Survival--an assessment of the unit's ability to survive and operate/ continue the mission under simulated conditions of enemy attack.

c. Successful conduct of a field training exercise (FTX) depends upon a complete scenario based on the ARTEP and good control by battery leaders. Any FTX should be conducted with training to ARTEP standards in mind. The success of the Pershing battery in wartime will depend heavily on the proficiency of individual soldiers, crews, and the battery.

d. A well-conducted FTX gives the battery commander two well-defined products. First, it demonstrates the ability of the entire unit to perform under simulated combat conditions and identifies requirements for future training. Second, it offers a test of those skills and techniques taught during previous exercises.

E-6. SKILL QUALIFICATION TEST

While the ARTEP is critical to the unit, the soldier's manual (SM) and skill qualification test (SQT) are critical to the individual soldier. A soldier's manual describes what is expected of each soldier at each skill level for that MOS. It contains instructions on how to learn new skills, cites references, and explains the standards that must be met for evaluation (SQT). The soldier cannot be promoted unless he qualifies for award of the next higher skill level. These individual tasks, when taken collectively, form the ARTEP objectives.

E-7. TACTICAL EXERCISE WITHOUT TROOPS

a. A tactical exercise without troops (TEWT) involves nothing more than a leader taking his subordinates to a predetermined location and discussing application of various tactical principles. During this exercise, the disposition and/or movement of simulated troops or

equipment is planned and discussed. Below are some examples of the application of this technique.

b. One example is a TEWT involving the battery commander accompanied by his XO, 1SG, platoon leaders, platoon sergeants, and communications chief. The BC would go with these subordinates to different tentative firing positions. An informal, two-way, question and-answer discussion should be conducted to surface problem areas and resolve them before a tactical exercise. Topics to discuss include--

- (1) Positioning of erector-launchers.
- (2) Organization of the position area.
- (3) Installation of communications.
- (4) Entrance/exit routes.
- (5) Locations of LP/OPs.
- (6) Employment of crew-served weapons.

c. The BC need not make meticulous preparation for the TEWT, but he must have a firm idea of the tactical principles of reconnaissance, selection, and occupation of a position.

d. A TEWT may be conducted at the platoon level. In this case, the platoon leader and platoon sergeant go with the ACSs to a tentative firing position and take the same type of actions as discussed in b and c above.

e. This can be a very effective training tool in that it allows the BC/platoon leader to spend a great deal of time with subordinates. Concurrently, subordinate leaders are made aware of problems that could be encountered in a position before an actual tactical exercise.

E-8. MAP EXERCISE

a. A map exercise (MAPEX) is an exercise for unit leaders. It is conducted in a closed environment, such as a classroom, with a simulated wartime scenario and a map of the area of operation. Individual leaders should be assigned the task of orally presenting a detailed, step-by-step plan of what will be accomplished for specific portions of the operation. The assignments can go out in advance to let the leaders prepare their presentations thoroughly, or the assignments can be given out during the exercise to develop the leader's ability to think on his feet.

b. The exercise may be conducted at battery or battalion level, depending on the desired scope of the exercise.

c. A MAPEX should be conducted before an FTX, ARTEP, or other field maneuver and should follow the same scenario; i.e., from roll-out/load-out through final firing operations in the field.

d. Many problems may be solved prior to a unit actually going to the field through the idea exchange at a MAPEX.

E-9. COMMUNICATIONS EXERCISE

Effective training in Pershing operations depends on effective communications. To provide this support, the communications section must be at a satisfactory training level. A COMEX is a means by which this may be sustained. In the COMEX, the communications elements within the battalion go to the field with the goal of establishing all necessary communications circuits. These exercises should be conducted frequently. If it is not possible to send the unit's communications assets to the field, training may be done in garrison. This is called a net exercise (NETEX).

E-10. NBC TRAINING

To survive in a nuclear or chemical environment, a soldier must be well trained and must be given opportunities to put his NBC skills into practice. One way to maintain NBC proficiency is to integrate NBC situations into field problem scenarios. Another way to train and practice NBC skills is to conduct a round-robin set of NBC training stations. These stations should cover those common knowledge soldier tasks in the soldier's manual for each MOS in the unit. The soldier should be given a GO or NO GO rating for his performance at each station with a set standard to be considered NBC proficient. (At least 80 percent on all tasks by 80 percent of the unit is recommended to consider the unit NBC proficient.) A sample list of stations might include the following:

- a. Put on and wear an M17-series protective mask.
- b. Perform operator's maintenance on an M17-series protective mask.
- c. Identify a chemical agent using the ABC-M8 or M9 detection paper or the M256 detection kit.
- d. Decontaminate self.
- e. Decontaminate individual equipment.
- f. Recognize symptoms of a nerve agent and demonstrate related first aid measures.
- g. Recognize symptoms of a blood agent and demonstrate related first aid measures.

- h. Read and report radiation dosages.
- i. Use the M256 chemical detection kit.

APPENDIX F
ESSENTIAL ELEMENTS OF FRIENDLY INFORMATION

Essential elements of friendly information (EEFI) are knowledge of a weapon system's operation, capabilities, and vulnerabilities, which, if placed in the wrong hands, could give the Threat a tactical/strategic advantage. Therefore, EEFI must be protected in peacetime, as well as during periods of hostility. The distribution statement on the cover of this FM, and required on all FMs, helps protect the information in this manual.

Training of battery personnel in EEFI is the battery commander's responsibility. All personnel are responsible for safeguarding EEFI. Personnel should never discuss unit activities outside their work areas or with people not in their unit. The EEFI should never be discussed over nonsecure means of communication, such as telephones. The following are the EEFI within the Pershing II system:

- a. Range of Pershing II system.
- b. Specific performance characteristics that would indicate weaknesses in the system or methods of exploitation.
- c. Classified/FOUO information related to Pershing.
- d. Specific details of planned or employed security measures.
- e. Specific details of mobile security measures and SOPs for movement or displacement.
- f. Specific plans identifying deployment areas or methods of deployment.
- g. Specific electronic security (ELSEC) countermeasures, including the Pershing II system's signature denial information; i.e., masking/ screening techniques.
- h. Technical countersurveillance measures or plans for countermeasures.
- i. The SOPs for field emplacements and/or design peculiarities causing patterned emplacement in the field.
- j. Operating frequencies of radios, ground guidance systems, or radar.
- k. Names of key personnel.
- l. Extreme personal problems of operators and crewmen.
- m. Shortages of personnel.

- n. Specific contingency or alert plans.
- o. Deployment sequences and times of deployment.
- p. Morale problems.
- q. Maintenance posture of unit.
- r. Equipment shortages.
- s. Identification of sensitive equipment or components.
- t. Training status.
- u. Document identifications (operating orders, plans, contingencies, or any document that would indicate an increased readiness posture).
- v. Information regarding communications nets for use in emergencies and/or deployment.
- w. Pershing II system vulnerabilities.
- x. Communications support unique to reporting.
- y. Information on mobilization, locations of assembly areas, control points for emergency usage, and operations centers.
- z. Up-to-date classification guide relating to the Pershing II system.

APPENDIX G
INTERNATIONAL STANDARDIZATION
AGREEMENTS

G-1. GENERAL

Standardization agreements (STANAGs and QSTAGs) are international agreements designed to facilitate allied operations. Upon ratification by the United States, these standardization agreements are binding upon the United States Forces (entirely or with exceptions as noted).

a. STANAG

A STANAG is the record of an agreement among several or all of the member nations of NATO to adopt like or similar military equipment, ammunition, supplies, and stores and operational, logistic, and administrative procedures. A list of STANAGs in use or under development is published in NATO Allied Administrative Publication (AAP) 4.

b. QSTAG

A QSTAG is an agreement between two or more ABCA countries (United States, United Kingdom, Canada, and Australia) similar in scope to a STANAG. A list of QSTAGs is published in the Quadripartite Standardization Agreement List (QSAL).

c. The following STANAGs/QSTAGs are included in this appendix:

- (1) STANAG 2008/QSTAG 503 - Bombing, Shelling, Mortaring and Location Reports.
- (2) STANAG 2047/QSTAG 183 - Emergency Alarms of Hazard or Attack (NBC and Air Attack Only).
- (3) STANAG 2113/QSTAG 534 - Destruction of Military Technical Equipment.
- (4) STANAG 2154/QSTAG 539 - Regulations for Military Motor Vehicle Movement by Road.

G-2. STANAG 2008: BOMBING, SHELLING, MORTARING AND LOCATION REPORTS.
(Edition No. 4) NAVY/ARMY/AIR

ANNEX: A. Format for BOMREP, SHELREP, MORTREP or LOCATION REPORT.

Related Documents: STANAG 2020 - Operational Situation Reports.
STANAG 2103 - Reporting Nuclear Detonations,
Radioactive Fallout, and Biological and Chemical Attacks and
Predicting Associated Hazards.

AIM

1. The aim of this agreement is to standardize, for the use of the NATO Forces, the method of rendering reports on enemy bombing, shelling, mortaring and locations. AGREEMENT

2. It is agreed that the NATO Forces are to use the format shown at Annex A when rendering enemy bombing, shelling, mortaring and location reports. (Additional reporting required when NBC weapons are involved is covered in STANAG 2103.) Nations are free to use their own national forms once the basic information has been received by means of the code letters.

3. It is further agreed that the format is to be completed as detailed in the following paragraphs of this agreement.

CLASSIFICATION OF REPORTS

4. Completed reports are to be classified in accordance with current security regulations.

METHOD OF RENDERING AND TRANSMISSION

5. Reports are rendered as normal messages and are to be transmitted by the fastest means available.

CODE WORDS

6. Each transmission is to be preceded by one of the following code words:

- a. SHELREP (in the case of enemy artillery fire).
- b. MORTREP (in case of enemy mortar or rocket fire).
- c. BOMREP (in the case of enemy air attack).
- d. LOCATION REPORT (in the case of location of enemy target). (1)

Note (1). To avoid confusion with LOGREP (LOGISTIC REPORT) LOCATION REPORT is written and spoken in full.

SECURITY OF MESSAGES

7. The message is always transmitted in clear except as follows:
 - a. Unit of Origin-Paragraph A of Annex A. The current call sign, address group or equivalent is to be used.
 - b. Position of Observer-Paragraphs B and F.1.b. of Annex A. This is to be encoded if it discloses the location of a headquarters or an important observer post.
 - c. When the originator considers that the conditions prevailing warrant a higher classification (e.g., paragraph K, if required).

PARAGRAPHS

8. Each paragraph of the report has a letter and a heading. The headings may be included for each reference to facilitate completion, but only the letters are to be transmitted if the report is sent by radio or telephone.
9. Paragraphs which cannot be completed or are not applicable are omitted from the report.

IMPLEMENTATION OF THE AGREEMENT

10. This STANAG will be considered to have been implemented when the necessary orders/instructions to adopt the method described in this Agreement have been issued to the forces concerned.

ANNEX A TO STANAG 2008 (Edition No. 4)
FORMAT FOR BOMBING, SHELLING, MORTARING AND LOCATION REPORTS
(SECURITY CLASSIFICATION)
BOMREP, SHELREP, MORTREP OR LOCATION REPORT
(indicate which)

- A. UNIT OF ORIGIN. Use current call sign, address or group or code name.
- B. POSITION OF OBSERVER. Grid reference preferred - encode if this discloses the location of a headquarters or important observation posts.
- C. DIRECTION (FLASH, SOUND OR GROOVE) AND ANGLE OF FALL/DESCENT. (Omit for aircraft.) Grid bearing of flash, sound or groove of shell (state which) in mils, unless otherwise specified. The angle of fall or descent may be determined by placing a stick/rod in the fuze tunnel and measuring in mils, unless otherwise specified, the angle formed by the stick/rod in relation to the horizontal plane.
- D. TIME FROM.
- E. TIME TO.
- F. AREA BOMBED, SHELLED OR MORTARED.
1. Location to be sent as:
 - a. grid reference (clear reference is to be used)OR
 - b. grid bearing to impact points in mils, unless otherwise specified, and distance in meters from observer. This information must be encoded if paragraph B is encoded. (When this method is used, maximum accuracy possible is essential.)
 2. Dimensions of the area bombed, shelled or mortared to be given by:
 - a. the radius (in meters)OR
 - b. the length and the width (in meters).
- G. NUMBER AND NATURE OF GUNS, MORTARS, ROCKET LAUNCHERS, AIRCRAFT OR OTHER METHODS OF DELIVERY.
- H. NATURE OF FIRE. Adjustment, fire for effect, harassing, etc. (May be omitted for aircraft.)

I. NUMBER, TYPE AND CALIBER (State whether measured or assumed.) OF SHELLS, ROCKETS (OR MISSILES), BOMBS, ETC.

J. TIME OF FLASH TO BANG. (Omit for aircraft.)

K. DAMAGE. (Encode if required.)

L. REMARKS.

M. SERIAL NUMBER. (Each location which is produced by a locating unit is given a serial number.)

N. TARGET NUMBER. (If the weapon/activity has previously been given a target number, it will be entered in this column by the locating units.)

O. POSITION OF TARGET (the grid reference and grid bearing and distance of the located weapon/activity.)

P. ACCURACY (the accuracy to which the weapon/activity located. CEP in meters and the means of location if possible).

Q. TIME OF LOCATION (the actual time the location was made).

R. TARGET DESCRIPTION (dimensions if possible):

1. radius of target in meters

OR

2. target length and width in meters.

S. TIME FIRED (against hostile target).

T. FIRED BY.

U. NUMBER OF ROUNDS - TYPE OF FUZE AND PROJECTILES.

G-3. STANAG 2047: EMERGENCY ALARMS OF HAZARD OF ATTACK (NBC AND AIR ATTACK ONLY) (Edition No. 5) NAVY/ARMY/AIR

ANNEX: A. Alarm Signals

Related documents:	STANAG 2002 (NBC)-	Warning Signs for the Marking of Contaminated or Dangerous Land Areas, Complete Equipments, Supplies and Stores.
	ATP-45	Reporting Nuclear Detonations, Biological and Chemical Attacks, and Predicting and Warning of Associated Hazards and Hazard Areas
	STANAG 2104 (NBC)-	Friendly Nuclear Strike Warning.
	STANAG 2889 (ENGR)-	Marking of Hazardous Areas and Routes Through Them.

AIM

1. The aim of this agreement is to provide a standard method of giving emergency alarms within the NATO Forces operating on land, of:
 - a. Nuclear, biological or chemical (NBC) hazards and strikes.
 - b. Air attack.

AGREEMENT

2. Participating nations agree that NATO Forces, when operating on land, will use the alarm signals detailed herein to give emergency alarms of hazard or attack. Audible and visual alarm signals must be given by means which cannot easily be confused with other sounds or sights encountered in combat. The alarm signals will be given in all cases as soon as an attack or the presence of a hazard is detected. The alarm signals will be repeated throughout the unit area by all who hear or see the original alarm signal since most available alarm signals are generally limited in range. Additionally, audible and visual alarm signals should normally be supplemented by the simultaneous use of radio, telephone and public address systems.

DETAILS OF THE AGREEMENT

3. It is unlikely that personnel can understand and react quickly and correctly to more than two alarm signals. The following hazards require fast and correct reaction: use or presence of chemical or biological agents, and an imminent air attack or nuclear operation. Therefore,

alarm signals for these two hazards are mandatory. (See Note (1).) In the case of radiological contamination, a delay in personnel taking cover may be acceptable.

Note (1): No reference is made to ground attack in order to reduce to a minimum the number of signals. Signals for ground attack, if deemed necessary, remain the prerogative of field commanders.

4. The spoken word (vocal alarm signals) remains the most effective means of informing troops in an emergency.

5. Visual alarm signals are included to supplement the audible alarm signals under conditions when audible signals may be lost due to other noises or to replace audible signals when the tactical situation does not permit the use of sound:

a. Reliance should not be placed on visual alarm signals during the hours of darkness or in conditions of poor light.

b. Visual alarm signals should be used when purely audible signals may be lost due to other noise.

c. Visual signals should be used to warn those personnel arriving at a particular location of an imminent hazard.

d. Apart from the audio-visual signals detailed at para 2, Note 3 of annex A, normal signal flares are excluded from use as a color alarm signal for NBC and Air Attack.

6. The actual form of a visual signal and the method of its display are left to the discretion of the local commander. Only the color at annex A is mandatory. However, to aid recognition, whenever possible, the shapes recommended in para 1b and 2b should be used.

7. The alarm signals listed in this agreement are primarily intended to serve as alarms of enemy action. They may be used, however, in an emergency when friendly action could produce similar effects on own forces.

8. CONFLICT WITH CIVIL REGULATIONS

There are some differences between the alarm signals prescribed herein and some national civil defense alarm signals. These differences are considered minor for air attack. Reservations are indicated by each nation where nations or local regulations prohibit NATO forces operating in their territory from sounding alarm signals in exercises and/or alarm signals incompatible with the public warning system in wartime.

9. PRACTICE ALARM SIGNALS

In those cases where nations or local regulations preclude sounding alarm signals during exercises, local commanders should negotiate with

local authorities to obtain authorization to sound alarm signals periodically. In the absence of agreement, small alarm devices emitting sound similar to the prescribed audible alarm signals and having limited range should be used during exercises to keep personnel familiar with the audible alarm signals.

IMPLEMENTATION OF THE AGREEMENT

11. This STANAG is implemented when the necessary orders/instructions have been issued directing forces concerned to put the content of this agreement into effect.

ANNEX A TO STANAG 2047 (Edition 5)
EMERGENCY ALARMS AND WARNING SIGNS

The following are emergency alarms and warning signs for NATO Forces operating on land:

<u>TYPE OF HAZARD</u>	<u>VISUAL WARNING SIGN</u>	<u>AUDIBLE ALARM SIGNAL</u>
1a. Imminent Air Attack	1b. Red. Preferably square in shape.	1c. (1) Unbroken warbling siren for one minute. (2) Succession of long blasts on vehicle horns, whistles, bugles or other wind instruments in a ratio of 3:1; approximately 3 seconds on and 1 second off. (3) Vocal "Air Attack," or corresponding national term where only one nation is involved.
2a. Imminent arrival of or presence of chemical or biological agents or radiological hazards.	2b. (1) Black. Preferably triangular in shape. (2) Donning respirators and taking protective action followed by such hand signals as may be prescribed in local instructions.	2c. (1) Interrupted warbling sound on a siren. (2) Succession of short signals on vehicle or other horns or by beating metal or other objects in a ratio of 1:1; approximately 1 second on and 1 second off. (3) Vocal "Gas, gas, gas," or corresponding national term where only one nation is involved. (4) Vocal "Fallout, fallout, fallout,"

TYPE OF HAZARD

VISUAL WARNING SIGN

AUDIBLE ALARM SIGNAL

		(See Notes 1, 2, and 3 on page A-2.)	or corresponding national term where only one nation is involved.
3a. All Clear.	3b. Removal of appropriate warning sign.		3c. (1) Vocal "all clear (specify type of attack)" or corresponding national term when only one nation is involved. (2) Steady siren note for one minute or sustained blast on a vehicle horn, whistle, bugle or other wind instrument to indicate absence of all NBC and air attack hazards.

- NOTES:
1. Automatic alarms for the early and rapid detection of biological and chemical agents and radiological hazards may complement the devices referred to previously.
 2. A special audio-visual pyrotechnic signal producing a whistle sound and a yellow, red, yellow display of lights may be used. The combination of colours should be produced as near simultaneously as possible.
 3. Wearing respiratory protection in the presence of radiological hazards is not mandatory, but will be decided by the local commander.

G-4. STANAG 2113: DESTRUCTION OF MILITARY TECHNICAL EQUIPMENT (Edition No. 3) NAVY/ARMY/AIR

ANNEX: A. Priorities for Destruction of Parts of Military Technical Equipment.

AIM

1. The aim of this agreement is to standardize procedures governing destruction of military technical equipment by the NATO Forces. This equipment does not include medical equipment necessary for the wounded or sick who cannot be evacuated and risk falling into enemy hands.

AGREEMENT

2. Participating nations agree:

a. That it is essential to destroy, to the maximum degree possible, military technical equipment abandoned on land or in harbor during wartime operations, to prevent its eventual repair and use by the enemy.

b. To follow the principles and priorities set forth in this agreement for the destruction of their own equipment when required.

GENERAL

3. Detailed Methods. Detailed methods of destroying individual items of equipment are to be included in the applicable publications, user handbooks and drill manuals.

4. Means of Destruction. Nations are to provide the means of destroying their own equipment.

5. Degree of Damage.

a. General. Methods of destruction should achieve such damage to equipment and essential spare parts that it would not be possible to restore the equipment to a usable condition in the combat zone either by repair or by cannibalization.

b. Classified equipment. Classified equipment must be destroyed to such a degree as to prevent the enemy from duplicating it or learning its method of operation.

c. Associated classified documents. Any classified documents, notes, instructions, or other written material concerning the operation, maintenance, or use of the equipment, including drawings or parts lists, are to be destroyed in a manner which will render them useless to the enemy.

PRIORITIES AND METHODS OF DESTRUCTION

6. General

a. Priority must always be given to the destruction of classified equipment and associated documents.

b. When lack of time or means prevents complete destruction of equipment, priority should be given to the destruction of essential parts, and the same parts are to be destroyed on all similar equipment.

c. A guide to priorities for the destruction of parts for various groups of equipment is contained in Annex A to this STANAG.

7. Equipment installed in vehicles. Equipment installed in vehicles should be destroyed in accordance with the priorities for the equipment itself.

8. Spare parts. The same priority for destruction of component parts of a major item must be given to the destruction of similar components in spare parts storage areas.

9. Cryptographic equipment and material. The detailed procedure for the rapid and effective destruction of all types of cryptographic equipment and material is to be specified in the instructions issued by the appropriate authority for security of communications.

10. Authorization. The authority for ordering the destruction of equipment is to be vested in divisional and higher commanders, who may delegate it to subordinate commanders when necessary. Standing orders should cover the destruction of isolated equipments which have to be abandoned on the battlefield.

11. Reporting. The reporting of the destruction of equipment is to be done through command channels.

IMPLEMENTATION OF THE AGREEMENT

12. This STANAG is considered to be implemented when the principles and priorities indicated herein have been incorporated in appropriate national documents.

ANNEX A TO STANAG 2113 (Edition No. 3)
 DESTRUCTION OF MILITARY EQUIPMENT
 PRIORITIES FOR DESTRUCTION OF PARTS OF MILITARY
 TECHNICAL EQUIPMENT

EQUIPMENT	PRIORITY	PARTS
1. VEHICLES (INCLUDING TANKS AND ENGINEER EQUIPMENT)	1	Carburetor or/fuel pump/injector distributor/fuel tanks/fuel lines.
	2	Engine block and cooling system.
	3	Tires/tracks and suspensions.
	4	Mechanical or hydraulic systems (where applicable).
	5	Differentials/transfer cases.
	6	Frame.
2. GUNS	1	Breech, breech mechanism and spares.
	2	Recoil mechanism.
	3	Tube.
	4	Sighting and fire control equipment (Priority 1 for Anti-Aircraft guns).
	5	Carriage and tires.
3. SMALL ARMS	1	Breech mechanism.
	2	Barrel.
	3	Sighting equipment (including Infra-Red).
	4	Mounts.
4. OPTICAL EQUIPMENT	1	Optical parts.
	2	Mechanical components.

5. RADIO

set.

6. RADAR AND OTHER
ELECTRONIC
EQUIPMENT

- 1 Transmitter (oscillators and frequency generators) and IFF equipment.
- 2 Receiver including IFF equipment.
- 3 Remote control units or switchboard (exchanges) and operating terminals.
- 4 Power supply and/or generator
- 5 Antennas.
- 6 Tuning heads.
- 1 Frequency determining components, records, operating instructions, which are subject to security regulations, and identification material (Identification Friend or Foe (IFF)).
- 2 Antennas and associated components such as radiators, reflectors and optics.
- 3 Transmission lines and waveguides.
- 4 Transmitter high voltage components.
- 5 Control consoles, displays, plotting boards.
- 6 Cable systems.
- 7 Automatic devices.
- 8 Other control panels and generators.
- 9 Carriage and tires.

7. GUIDED MISSILE
SYSTEMS

- 1 Battery fire control centers.
- 2 Missile guidance equipment
(including homing systems).
- 3 Launchers including control
circuits.
- 4 Missiles.
- 5 Measuring and test equipment.
- 6 Generators and cable systems.

8. AIRCRAFT AND
SURVEILLANCE DRONES

- 1 Identification (IFF) equipment,
other classified and electronic
equipment, publications and
documents pertaining thereto,
and other material as defined by
the national government
concerned.
- 2 Installed armament (Use sub-
priorities for Group 2, Guns; or
Group 3, Small Arms, as
appropriate).
- 3 Engine Assembly (Priorities for
destruction of magnetos,
carburetors, compressors,
turbines and other engine
subassemblies to be determined
by national governments,
depending on type of aircraft
involved and time available for
destruction).
- 4 Airframe/control surfaces/
under-carriage (Priorities for
destruction of propellers,
hub-rotor blades, gear boxes,
drive shafts, transmissions, and
other subassemblies (not already
destroyed in Priority 3) to be
determined by national
governments, depending on type
of aircraft involved and time
available for destruction).

9. ROCKETS

- 5 Instruments, radios, and electronic equipment (not included in Priority 1).
- 6 Electrical, fuel and hydraulic systems.
 - 1 Launcher.
 - 2 Rocket.
 - 3 Sights and fire control equipment.

G-5. STANAG 2154/QSTAG 539: REGULATIONS FOR MILITARY MOTOR VEHICLE
MOVEMENTS BY ROAD (Edition No. 4) NAVY/ARMY/AIR

ANNEXES: A. Definitions

B. Special Movement

RELATED DOCUMENTS:	STANAG 1059-	National Distinguishing Letters for Use by NATO Armed Forces.
	STANAG 2021-	Computation of Bridge, Raft and Vehicle Classification.
	STANAG 2024-	Military Vehicle Lighting.
	STANAG 2025-	Basic Military Road Traffic Regulations.
	STANAG 2041-	Operation Orders, Tables and Graphs for Road Movement.
	STANAG 2155-	Road Movement Documents.
	STANAG 2159-	Identification of Movement Control and Traffic Control Personnel and Agencies.
	STANAG 2174-	Military Routes and Route/Road Networks.

AIM

1. The aim of this agreement is to set out the basic regulations applying to military motor movement by road for the use of the NATO Forces.

AGREEMENT

2. Participating nations agree to use the regulations applying to military motor movement by road, defined in the following paragraphs, except where they are contrary to national laws and/or regulations.

GENERAL

3. It is particularly important that movement and transport staffs, who are responsible for international road movements and transport are trained to understand and use the terms and definitions listed in annex A.

COLUMNS

4. A column is a group of vehicles moving under a single commander, over the same route, in the same direction.

5. A large column may be composed of a number of organized elements (formations, units or subunits).

6. Each column and organized element of the column should include:

- a. A commander whose location may vary.
- b. In the first vehicle: a subordinate commander known as the pace setter (AAP-6).
- c. In the last vehicle: a subordinate commander known as the trail officer (see annex A).

7. The pace setter of the first element of a column leads it and regulates its speed. The trail officer of the last element deals with such problems as occur at the tail of the column.

8. In addition, each vehicle is to have a vehicle commander (AAP-6) (who may be the driver) who is to be the leader of the vehicle crew appointed for each mission. He is responsible for crew discipline and the execution of the mission.

IDENTIFICATION OF COLUMNS

9. Each column is to be identified in accordance with the laws or regulations of the country within which movement is taking place by flags and/or lights and, in some cases, by a movement number (see annex A).

10. Each column which has received a movement credit (AAP-6) (see para 14 below) is to be identified by a number known as "the movement number" which is allocated by "the authority authorizing/arranging the movement." (See STANAG 2174.) This number identifies the column during the whole of the movement.

11. The movement number is to be placed on both sides and, if possible, on the front of at least the first vehicle and the last vehicle of each organized element of the column. It is to be permanently legible, from ground level, at a minimum distance of 6 meters in normal daylight and composed of:

- a. Two figures indicating the day of the month on which the movement is due to commence.
- b. Three or more letters indicating the authority organizing the movement, the first two letters being the national symbols of the column. (See STANAG 1059.)
- c. Two figures indicating the serial number (AAP-6) of the movement.
- d. One letter to identify the element of the column. (This is optional.) Example: Identification of 03-BEA-08-C will indicate that this is the 3rd of the month, moved by BE authority 'A', as column No. 8, element "C".

12. Additionally, each organized element of a column is to be identified by flags and/or for night movement, by lights, security permitting, as described below:

a. The first vehicle of each element of the column is to display a blue flag and a blue light at night if required by national laws or regulations of the country in which the vehicles are operating.

b. The last vehicle of each element of the column is to display a green flag and a green light at night, if required by national laws or regulations of the country in which the vehicles are operating.

c. The vehicle of the column commander is to display a white and black flag as indicated below, subject to the commander's discretion, in certain circumstances.



d. A vehicle that cannot maintain its position in a column should indicate this condition by displaying a yellow flag.

e. Flags should be approximately 30cm (12 in) x 45 cm (18 in) in size.

f. Flags and lights are to be mounted on the front side of the vehicles.

13. Headlights. In peacetime, all vehicles driving in a column are to use dipped headlights (low beam), even in daylight.

MOVEMENT CREDIT

14. A movement credit is the allocation granted by the authority (See paragraph 10 above.) to one or more vehicles in order to move over a controlled route in a fixed time according to movement instructions (See STANAG 2174.), a controlled route being a route the use of which is subject to traffic or movement restrictions (AAP-6).

15. The movement credit includes the indication of times at which the first and the last vehicle of the column are scheduled to pass:

- a. The entry point. (See annex A.)
- b. The exit point. (See annex A.)
- c. Critical points (See annex A.) and, if possible, at traffic control posts.

SPECIAL REGULATIONS FOR THE EXECUTION OF MOVEMENT

16. All personnel exercising a command in the column and all drivers must obey the instructions of traffic control and regulating personnel.

17. When approaching a traffic control or a regulating post indicated by prescribed signs (See STANAG 2025.) the column commander or his representative must advance ahead of his column and report to the post commander to:

a. Give the required information concerning formation/unit, route and destination.

b. Receive information and possible instructions.

18. Through this post, he can also arrange for the transmission of his own instructions, or information, to the various elements of his column as they pass the post, where however, they must not stop unless ordered to do so.

HALTS

19. Short halts:

a. Short halts made by columns or elements of columns on controlled routes normally are to last 10 minutes and in principle should be taken after every 1 hour and 50 minutes running. Wherever possible all columns following the same route should stop at the same time but movement planning must, where necessary, allow at least a 10 minute column gap or gap between columns to ensure that a following column does not overtake the one in front while it is halted.

b. However, the characteristics of the road may make it necessary for the halt to take place in one particular part of the route rather than simultaneously at a fixed time. In such cases, the necessary instructions are given in the orders relating to the movement.

20. Long halts. No standard rules for the observance of long halts are laid down. They must always be specifically plotted on movement graphs in order to avoid possible conflict.

21. Particular attention is to be paid to the following aspects of traffic discipline during halts:

a. When making a halt isolated vehicles, or vehicles forming part of a column, should move off the roads as much as possible.

b. If this practice cannot be observed, the commander of a column which is halted must take all necessary measures to facilitate movement of other road users and avoid accidents or traffic jams. The measures to be taken will vary according to the conditions and width of the road and should include:

(1) Warning at a sufficient distance from the front and rear of the column (guards, warning flags, lights or flares), security permitting.

(2) Organizing and directing a system of one-way traffic along the column.

c. When a halted column resumes movement, it has the right of way while moving back on to the road, unless otherwise prescribed.

OVERTAKING OF COLUMNS

22. By isolated vehicles:

a. An isolated vehicle is authorized to overtake a moving column only when:

(1) Its maximum authorized speed is appreciably higher than the speed at which the column is moving, thus enabling it to overtake each vehicle rapidly.

(2) There is sufficient distance between the vehicles of the column to allow the overtaking vehicle to regain its position in the proper lane after overtaking each vehicle.

(3) The trail officer of the column gives a clear signal that overtaking is possible.

b. In all other cases, an isolated vehicle is to overtake the column only when the latter is halted.

23. By other columns:

a. On a controlled route a column may overtake another column only on the orders of the movements authorities and as arranged by the traffic regulating personnel.

b. On an open route no column may overtake another moving column, except in special cases, e.g., on a one-way road which is wide enough. In these cases, the commander of the column desiring to pass is to contact the commander of the column to be passed prior to attempting to pass.

c. Outside these special cases, the overtaking of a column by another column is authorized only if the former is halted and provided the moving column has the time to overtake the whole of the halted column before the latter is ready to move. In this case, the commander of the column desiring to pass is to contact the commander of the column to be passed prior to attempting to pass. The commander of the halted column after giving his agreement, must facilitate the overtaking.

MOVING BY NIGHT

24. Normal conditions. By night, road movement is to be carried out in accordance with national laws and regulations of the country in which the vehicles are operating.

25. Emergency conditions. See STANAG 2024.

ROAD MOVEMENT OF MOTOR VEHICLES/EQUIPMENT

26. The movement by road of certain outsize or heavy vehicles/equipment is restricted by limitations imposed by the different nations. These will call for the application of special procedures and, where necessary, specialized methods, to effect the movement of such equipment and vehicles whether loaded or not.

27. Annex B outlines, with regard to each nation, the class and gage limits beyond which a road movement becomes a special movement.

IMPLEMENTATION OF THE AGREEMENT

28. This STANAG will be considered to have been implemented when the necessary orders/instructions to use the definitions and regulations contained in this agreement have been issued to the forces concerned.

ANNEX A TO STANAG 2154 (Edition No. 4)
REGULATIONS FOR MILITARY MOTOR VEHICLE MOVEMENT BY ROAD
DEFINITIONS

1. Definitions already included in AAP-6:

a. Those concerning time and distance factors in motor columns:

- Column Gap.
- Road Clearance Time.
- Traffic Flow.
- Traffic Density.
- Road Space.
- Pass Time.
- Average Speed.

b. Those concerning formation and dispersal of columns:

- Start Point.
- Release Point.

2. Definitions used for the purpose of this Agreement only:

-Blackout lighting. A condition in which lights are so used that they cannot be spotted by enemy observation but which prevent collisions by showing the position of the vehicle to other road users.

-Column length. "Column Length" or "Length of a Column" is the length of roadway occupied by a column in movement including the gaps within the column from the front of the leading vehicle to the rear of the last vehicle.

-Column. A group of vehicles moving under a single commander, over the same route, in the same direction.

-Critical point. That point on a route where any restriction of traffic flow could cause disruption.

-Road movement graph. Used by the staffs in planning, supervising and regulating complicated road movements and for providing a convenient means of recording actual moves of units over a period.

-Movement number. The numeric identification of a movement credit.

-Normal lighting. Normal lighting is as prescribed or authorized by law of a given country without restrictions for military reasons.

-Open route. Routes not subject to traffic or movement control restrictions.

-Reduced lighting (vehicles). Reduced lighting implies that the brightness of all vehicle lights should be reduced by either reduction in power or by screening in such a way that any visible light is limited in output.

-Special movement. The movement of outsize or heavy vehicles/equipment which is limited by legal restrictions of class or gage of the host nation.

-Traffic post. The post from which traffic control is operated.

-Trail officer. A subordinate commander in each column of vehicles and each organized element of that column who deals with such movement problems that occur at the tail of the column/element of that column.

-Vehicle distance. The space between two consecutive vehicles of a column measured from the front of one vehicle to the front of the vehicle following. Vehicle distance has a relation to density.

-Entry point. The point where a column enters a controlled route.

-Exit point. The point where a column leaves a controlled route.

ANNEX B TO STANAG 2154 (Edition No. 4)
REGULATIONS FOR MILITARY MOTOR VEHICLE MOVEMENT BY ROAD
SPECIAL MOVEMENT

INTRODUCTION

1. The expression "Special Movement" means movement of vehicles/equipment with or without load which, because of their class and/or dimensions, require special routing arrangements.

LIMITATIONS AFFECTING ROAD MOVEMENT

2. The conditions for the road movement of military equipment and vehicles are governed by the capabilities of existing road networks as defined in STANAG 2174. Further, the special regulations in force in the different countries place certain limitations on ordinary road movement of:

- a. Individual wheeled or tracked vehicles, whether loaded or not.
- b. Articulated vehicles consisting of a prime mover and semi-trailer.
- c. Articulated trains of vehicles consisting of a tractor and one or more trailers.
- d. Passenger transport vehicles (motor coaches).

3. These limitations, details of which are given at appendix L to this annex for each country concerned with this agreement, relate to some or all of the following characteristics of the:

- a. Width measured on any cross-section, including all projections.
- b. Length (of vehicle or train of vehicles), including all projections and, where applicable, length of each part of the train: tractor + trailer(s).
- c. Total height of the vehicle, including load, if any.
- d. Turning radius.
- w. Class of vehicle (or train of vehicles), calculated according to the method laid down in STANAG 2021.

RULES GOVERNING SPECIAL MOVEMENT

4. Any road movement of military equipment and vehicles of which one or more of the characteristics listed in paragraph 3 above exceeds the corresponding limitation(s) imposed by the regulations in force in any of the countries in which it will have to move constitutes a "special movement" in the country concerned.

ACRONYMS

AAP	allied administrative publication
ACS	assistant chief of section
ARTEP	Army training and evaluation program
BC	battery commander
BCC	battery control central
BOC	battalion operations center
BOMREP	bombing report
CB	chemical/biological
CEP	circular error probable
CEOI	communications-electronics operating instructions
cGy	centigray
COMDEX	communications exercise
COMSEC	communications security
CP	checkpoint
CSS	combat service support
DCC	defense control center
DMA	Defense Mapping Agency
DS	direct support
EEFI	essential elements of friendly information
EFP	external firing point
EL	erector-launcher
ELSEC	electronic security
EOL	end of the orienting line
EMP	electromagnetic pulse
EW	electronic warfare

1SG	first sergeant
FLOT	forward line of own troops
FORSTAT	forces status
FPL	final protective line
FTX	field training exercise
G&C/A	guidance and control/adapter
GIEU	ground integrated electronic unit
GS	general support
GSE	ground support equipment
HF	high frequency
HHB	headquarters and headquarters battery
HH&S	headquarters headquarters and service
IFF	identification, friend or foe (radar)
ILA	interface logic assembly
JCS	Joint Chiefs of Staff
LOGREP	logistic report
LP	listening post
MAPEX	map exercise
METT-T	mission, enemy, terrain, and troops -time
MOPP	mission oriented protective posture
MORTREP	mortar bombing report
M&S	maintenance and supply
MTOE	modified tables or organization and equipment
NATO	North Atlantic Treaty Organization
NBC	nuclear, biological, chemical
NCA	National Command Authority

NCS	net control station
NDPR	nuclear duty position roster
NUCON	nuclear convoy
ODB	operational data base
OIC	officer in charge
OP	observation post
OPORD	operation order
PII	Pershing II
PADS	position and azimuth determining system
PAL	permissive action link
PC	platoon center
PCC	platoon control center
PDF	principal direction of fire
PMCS	preventive maintenance checks and services
POL	petroleum, oils and lubricants
PRP	personnel reliability program
PX	post exchange
QRA	quick reaction alert
QSAL	quadripartite standardization agreement list
QSTAG	quadripartite standardization agreement
RATT	radio teletypewriter
RDF	radio direction finding
REC	radioelectronic combat
RF	radio frequency
RLCU	remote launch control unit
RP	release point

RSGF	reference scene generation facility
RSOP	reconnaissance selection and occupation of position
RV	reentry vehicle
SAS	sealed authentication systems
SCP	survey control point
SF	standard form
SHELREP	shelling report
SIC	survey information center
SM	soldier's manual
SP	start point
SQT	skill qualification test
SSB	single sideband
STANAG	standardization agreement
T&E	traverse and elevating mechanism
TACSAT	tactical satellite
TDA	tables of distribution and allowances
TEWT	tactical exercise without troops
UTM	Universal Transverse Mercator
X-gate	exclusion area gate
XO	executive officer

INDEX
TO BE PUBLISHED